



# AIR-COOLED SCROLL COMPRESSOR CONDENSING UNITS

INSTALLATION, OPERATION  
& MAINTENANCE

NEW RELEASE

Form QCC2-NM1 (617)

035-26916-000

## QCC2015CEE – QCC2070CEE AIR-COOLED SCROLL COMPRESSOR CONDENSING UNITS STYLE E (60 HZ) 15 - 80 TON 50-280KW



R-410A



Products are produced at a facility whose quality-management systems are ISO9001 certified.

Issue Date:  
June 30, 2017



# IMPORTANT!

## READ BEFORE PROCEEDING!

### GENERAL SAFETY GUIDELINES

This equipment is a relatively complicated apparatus. During rigging, installation, operation, maintenance, or service, individuals may be exposed to certain components or conditions including, but not limited to: heavy objects, refrigerants, materials under pressure, rotating components, and both high and low voltage. Each of these items has the potential, if misused or handled improperly, to cause bodily injury or death. It is the obligation and responsibility of rigging, installation, and operating/service personnel to identify and recognize these inherent hazards, protect themselves, and proceed safely in completing their tasks. Failure to comply with any of these requirements could result in serious damage to the equipment and the property in

which it is situated, as well as severe personal injury or death to themselves and people at the site.

This document is intended for use by owner-authorized rigging, installation, and operating/service personnel. It is expected that these individuals possess independent training that will enable them to perform their assigned tasks properly and safely. It is essential that, prior to performing any task on this equipment, this individual shall have read and understood the on-product labels, this document and any referenced materials. This individual shall also be familiar with and comply with all applicable industry and governmental standards and regulations pertaining to the task in question.

---

### SAFETY SYMBOLS

The following symbols are used in this document to alert the reader to specific situations:



*Indicates a possible hazardous situation which will result in death or serious injury if proper care is not taken.*



*Identifies a hazard which could lead to damage to the machine, damage to other equipment and/or environmental pollution if proper care is not taken or instructions and are not followed.*



*Indicates a potentially hazardous situation which will result in possible injuries or damage to equipment if proper care is not taken.*

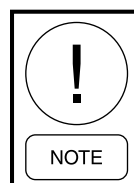

*Highlights additional information useful to the technician in completing the work being performed properly.*



*External wiring, unless specified as an optional connection in the manufacturer's product line, is not to be connected inside the control cabinet. Devices such as relays, switches, transducers and controls and any external wiring must not be installed inside the micro panel. All wiring must be in accordance with Quantech published specifications and must be performed only by a qualified electrician. Quantech will NOT be responsible for damage/problems resulting from improper connections to the controls or application of improper control signals. Failure to follow this warning will void the manufacturer's warranty and cause serious damage to property or personal injury.*

## CHANGEABILITY OF THIS DOCUMENT

In complying with Quantech policy for continuous product improvement, the information contained in this document is subject to change without notice. Quantech makes no commitment to update or provide current information automatically to the manual or product owner. Updated manuals, if applicable, can be obtained by contacting the nearest Quantech Service office.

It is the responsibility of rigging, lifting, and operating/service personnel to verify the applicability of these documents to the equipment. If there is any question regarding the applicability of these documents, rig-

ging, lifting, and operating/service personnel should verify whether the equipment has been modified and if current literature is available from the owner of the equipment prior to performing any work on the chiller.

### CHANGE BARS

Revisions made to this document are indicated with a line along the left or right hand column in the area the revision was made. These revisions are to technical information and any other changes in spelling, grammar or formatting are not included.

---

## ASSOCIATED LITERATURE

MANUAL DESCRIPTION	FORM NUMBER
Renewal Parts	QCC2-RP1

## NOMENCLATURE

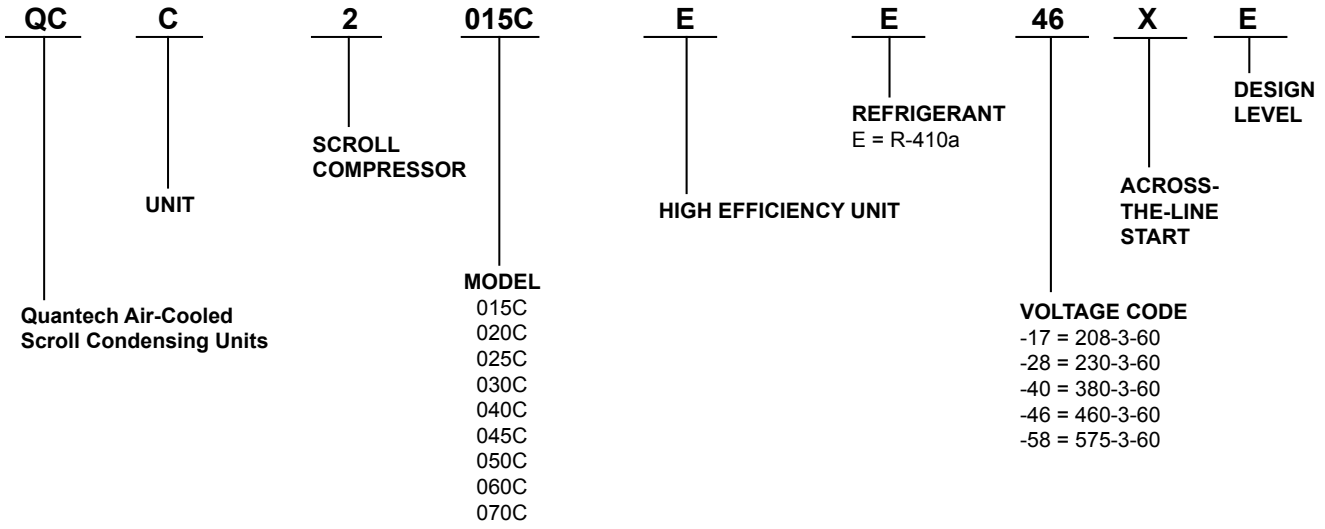



## TABLE OF CONTENTS

<b>SECTION 1 – GENERAL EQUIPMENT INFORMATION AND SAFETY</b> .....	<b>9</b>
Introduction.....	9
Compressors.....	9
Condenser.....	9
Refrigerant Circuit.....	9
Warranty.....	9
Safety and Quality.....	10
About this Manual.....	10
Misuse of Equipment.....	10
<b>SECTION 2 – PRODUCT DESCRIPTION</b> .....	<b>13</b>
Introduction.....	13
General System Description.....	13
Microcomputer Control Center.....	14
Building Automation System Interface.....	15
Communications.....	15
Power Panel.....	15
Accessories and Options.....	16
Discharge Pressure Transducers and Readout Capability.....	16
Basic Unit.....	21
<b>SECTION 3 – HANDLING AND STORAGE</b> .....	<b>27</b>
Delivery And Storage.....	27
Inspection.....	27
Unit Rigging.....	27
<b>SECTION 4 – INSTALLATION</b> .....	<b>29</b>
Installation Checklist.....	29
Handling.....	29
Location And Clearances.....	29
Spring Isolators (Optional).....	30
Compressor Mounting.....	30
Pipework Arrangement.....	30
Duct Work Connection.....	30
Recommendations Of The Building Services Research Association.....	30
Wiring.....	30
High Pressure Cutout.....	32
Compressor Heaters.....	32
Refrigerant Piping.....	32
Oil Traps.....	35
Refrigerant Charge.....	35
Refrigerant Piping Reference.....	35
Filter Driers / Sight Glasses/ Txv's.....	35
<b>SECTION 5 – TECHNICAL DATA</b> .....	<b>39</b>
<b>SECTION 6 – COMMISSIONING</b> .....	<b>95</b>
Preparation – Power Off.....	95
Preparation – Power On.....	96

## TABLE OF CONTENTS (CONT'D)

<b>SECTION 7 – UNIT CONTROLS .....</b>	<b>101</b>
Introduction.....	101
Microprocessor Board .....	101
Unit Switch .....	102
Display.....	102
Keypad .....	102
Battery Back-Up .....	102
Transformer .....	102
Single System Select and Programming # Of Compressors.....	102
 <b>SECTION 8 – UNIT OPERATION .....</b>	 <b>131</b>
Capacity Control.....	131
Suction Pressure Limit Controls .....	131
Discharge Pressure Limit Controls .....	131
Discharge Air Temperature Control .....	131
Suction Pressure Control .....	133
System Lead/Lag .....	134
Compressor Lead/Lag .....	134
Anti-Recycle Timer .....	134
Anti-Coincidence Timer .....	134
Evaporator Blower Control .....	134
Evaporator Heater Control .....	134
Pumpdown Control.....	134
Load Limiting .....	137
Compressor Run Status .....	137
Alarm Status .....	137
BAS/EMS Discharge Air Temperature Reset Using a Voltage or Current Signal .....	138
 <b>SECTION 9 – SERVICE AND TROUBLESHOOTING.....</b>	 <b>139</b>
Clearing History Buffers.....	139
Service Mode .....	139
Service Mode – Outputs.....	139
Service Mode – Condensing Unit Configuration .....	140
Service Mode – Analog and Digital Inputs.....	140
Control Inputs/Outputs .....	141
Checking Inputs And Outputs.....	143
Optional Printer Installation .....	147
 <b>SECTION 10 – MAINTENANCE.....</b>	 <b>151</b>
Important .....	151
Compressors .....	151
Condenser Fan Motors.....	151
Condenser Coils.....	151
Operating Parameters .....	151
On-Board Battery Back-Up.....	151
Overall Unit Inspection .....	151
Bacnet, Modbus And Yorktalk 2 Communications .....	152

## LIST OF FIGURES

<b>FIGURE 1</b> - Quantech Air-Cooled Scroll Compressor Condensing Unit .....	13
<b>FIGURE 2</b> - Unit Components Front.....	18
<b>FIGURE 3</b> - Power Panel Components .....	19
<b>FIGURE 4</b> - Power Panel / Control Components .....	20
<b>FIGURE 5</b> - Refrigerant Flow Diagram.....	25
<b>FIGURE 6</b> - Process and Instrumentation Diagram .....	26
<b>FIGURE 7</b> - Unit Rigging .....	27
<b>FIGURE 8</b> - Single-Point Supply Connection – Terminal Block, Non-Fused Disconnect Switch or Circuit Breaker .....	36
<b>FIGURE 9</b> - Discharge Air Sensor Field Wiring .....	36
<b>FIGURE 10</b> - Control Wiring .....	37
<b>FIGURE 11</b> - Control Wiring Diagram, Single Circuit, IPU II .....	48
<b>FIGURE 12</b> - Control Wiring Diagram, Single Circuit, IPU II .....	50
<b>FIGURE 13</b> - Control Wiring Diagram, Dual Circuit, IPU II.....	52
<b>FIGURE 14</b> - Control Wiring Diagram, Dual Circuit, IPU II.....	54
<b>FIGURE 15</b> - Control Wiring Diagram, Details, Single Circuit .....	56
<b>FIGURE 16</b> - Control Wiring Diagram, Details, Dual Circuit.....	58
<b>FIGURE 17</b> - Power Wiring, Single Circuit .....	60
<b>FIGURE 18</b> - Power Wiring, Single Circuit .....	62
<b>FIGURE 19</b> - Power Wiring, Single Circuit .....	64
<b>FIGURE 20</b> - Power Wiring, Single Circuit .....	66
<b>FIGURE 21</b> - Power Wiring, Dual Circuit.....	68
<b>FIGURE 22</b> - Power Wiring, Dual Circuit.....	70
<b>FIGURE 23</b> - Connection Wiring, Single Circuit .....	72
<b>FIGURE 24</b> - Connection Wiring, Single Circuit .....	74
<b>FIGURE 25</b> - Connection Wiring, Single Circuit .....	76
<b>FIGURE 26</b> - Connection Wiring, Single Circuit .....	78
<b>FIGURE 27</b> - Connection Wiring, Dual Circuit.....	80
<b>FIGURE 28</b> - Connection Wiring, Dual Circuit.....	82
<b>FIGURE 29</b> - Unit Clearances – All Models.....	86
<b>FIGURE 30</b> - Sample Isolator Location Drawing .....	87
<b>FIGURE 31</b> - Isolator Locations, 60 HZ.....	88
<b>FIGURE 32</b> - One Inch Deflection Spring Isolator Cross-Reference.....	89
<b>FIGURE 33</b> - One Inch Deflection Spring Isolators Installation Instructions.....	90
<b>FIGURE 34</b> - Two Inch Deflection Seismic Isolator Cross-Reference.....	91
<b>FIGURE 35</b> - Seismic Isolator Installation And Adjustment .....	92
<b>FIGURE 36</b> - Durulene Isolator Cross-Reference .....	93
<b>FIGURE 37</b> - Installation of Durulene Vibration Isolators .....	94
<b>FIGURE 38</b> - Discharge Air Temperature Control.....	132
<b>FIGURE 39</b> - Suction Pressure Control.....	133
<b>FIGURE 40</b> - QCC2040C – QCC2070C Fan Location (Typical) .....	135
<b>FIGURE 41</b> - Microboard Layout.....	142
<b>FIGURE 42</b> - I/O Board Relay Contact Architecture.....	146
<b>FIGURE 43</b> - Printer to Microboard Electrical Connections.....	147
<b>FIGURE 44</b> - Micro Panel Connections.....	153

## LIST OF TABLES

<b>TABLE 1</b> - Fitting Equivalent Lengths .....	33
<b>TABLE 2</b> - Refrigerant Piping Charges .....	33
<b>TABLE 3</b> - Miscellaneous Liquid Line Pressure Drops .....	34
<b>TABLE 4</b> - Refrigerant Line Connections .....	34
<b>TABLE 5</b> - Voltage Limitations .....	39
<b>TABLE 6</b> - Physical Data (English) .....	40
<b>TABLE 7</b> - Micro Panel Power Supply .....	41
<b>TABLE 8</b> - Voltage Range .....	41
<b>TABLE 9</b> - Status Key Messages Quick Reference List .....	108
<b>TABLE 10</b> - Operation Data .....	112
<b>TABLE 11</b> - Cooling Setpoints Programmable Limits and Defaults .....	123
<b>TABLE 12</b> - Program Key Limits and Defaults .....	123
<b>TABLE 13</b> - Setpoints Quick Reference List .....	124
<b>TABLE 14</b> - Options Key Programming Quick Reference List .....	130
<b>TABLE 15</b> - Discharge Air Temperature Control for 5 and 6 Compressors (7 And 8 Steps) .....	132
<b>TABLE 16</b> - Discharge Air Temperature Control for 4 Compressors (6 Steps) .....	132
<b>TABLE 17</b> - QCC2015C – QCC2070C Condenser Fan Control Using Outdoor Ambient Temperature and Discharge Pressure (Discharge Pressure Controls Will Not Function Unless the Optional Discharge Pressure Transducer is Installed) .....	135
<b>TABLE 18</b> - QCC2040C – QCC2070C Condenser Fan Control Using Discharge Pressure Only .....	135
<b>TABLE 19</b> - QCC2015C – QCC2070C Low Ambient Condenser Fan Control – Discharge Pressure Control .....	136
<b>TABLE 20</b> - QCC2015C – QCC2030C Low Ambient Condenser Fan Control – Discharge Pressure Control .....	136
<b>TABLE 21</b> - Compressor Operation – Load Limiting .....	137
<b>TABLE 22</b> - I/O Digital Inputs .....	141
<b>TABLE 23</b> - I/O Digital Outputs .....	141
<b>TABLE 24</b> - I/O Analog Inputs .....	141
<b>TABLE 25</b> - I/O Analog Outputs .....	141
<b>TABLE 26</b> - Outdoor Air Sensor Temperature/Voltage/ Correlation .....	143
<b>TABLE 27</b> - Discharge Air Temp. Sensor Temperature/Voltage/Resistance Correlation .....	144
<b>TABLE 28</b> - Pressure Transducers .....	145
<b>TABLE 29</b> - Troubleshooting .....	148
<b>TABLE 30</b> - Minimum, Maximum And Default Values .....	153
<b>TABLE 31</b> - Values Required For Bas Communication .....	154
<b>TABLE 32</b> - Real Time Error Numbers .....	154
<b>TABLE 33</b> - Bacnet and Modbus Communications Data Map .....	156
<b>TABLE 34</b> - Yorktalk 2 Communications Data Map .....	160

## SECTION 1 – GENERAL EQUIPMENT INFORMATION AND SAFETY

### INTRODUCTION

The 15 through 80 Ton (50 through 280 kW) QCC2 models are shipped complete from the factory ready for field installation.

The unit is pressure-tested, evacuated and given a nitrogen holding charge and includes an initial oil charge (R-410A refrigerant supplied by others). After assembly, an operational test is performed to assure that each control device operates correctly.

The unit structure is heavy-gauge, galvanized steel. This galvanized steel is coated with baked-on powder paint which, when subjected to ASTM B117 1000 hour salt spray testing, yields a minimum ASTM 1654 rating of “6”. Units are designed in accordance with NFPA 70 (National Electric Code), ASHRAE/ANSI 15 Safety code for mechanical refrigeration, and are cETL listed. All units are produced at an ISO 9000-registered facility.

### COMPRESSORS

The condensing unit has suction-gas cooled, hermetic, scroll compressors. The compressors incorporate a compliant scroll design in both the axial and radial direction. All rotating parts of the compressors are statically and dynamically balanced. A large internal volume and oil reservoir provides greater liquid tolerance. Compressor crankcase heaters are also included for extra protection against liquid migration.

### CONDENSER

#### Coils

Fin and tube condenser coils of seamless, internally-enhanced, high-condensing-coefficient, corrosion resistant copper tubes are arranged in staggered rows, mechanically expanded into aluminum fins. Integral subcooling is included. The design working pressure of the coil is 650 psig (45 barg).

#### Low Sound Fans

The condenser fans are composed of corrosion resistant aluminum hub and composite blades molded into a low noise airfoil section. They are designed for maximum efficiency and are statically and dynamically balanced for vibration-free operation. They are directly driven, and positioned for vertical air discharge. The fan guards are constructed of heavy-gauge, rust-resistant, PVC (polyvinyl chloride)-coated steel wire.

### Motors

The fan motors are Totally Enclosed Air-Over, squirrel-cage type, current protected. They feature ball bearings that are double-sealed and permanently lubricated.

### REFRIGERANT CIRCUIT

All unit piping will be copper with brazed joints. The liquid line will include a field connection shutoff valve with charging port located on each condenser circuit. Suction line connections are provided on each refrigeration circuit. A filter drier and sight glass are shipped loose for field installation on each refrigerant circuit.

All expansion valves, liquid line solenoid valves, refrigerant, and refrigerant field piping are supplied by others.

### WARRANTY

Quantech warrants all equipment and materials against defects in workmanship and materials for a period of eighteen months from date of shipment, unless labor or extended warranty has been purchased as part of the contract.

The warranty is limited to parts only replacement and shipping of any faulty part, or sub-assembly, which has failed due to poor quality or manufacturing errors. All claims must be supported by evidence that the failure has occurred within the warranty period, and that the unit has been operated within the designed parameters specified.

All warranty claims must specify the unit model, serial number, order number and run hours/starts. Model and serial number information is printed on the unit identification plate.

The unit warranty will be void if any modification to the unit is carried out without prior written approval from Quantech.

For warranty purposes, the following conditions must be satisfied:

- The initial start of the unit must be carried out by trained personnel from an Authorized Quantech Service Representative (*see SECTION 6 – COMMISSIONING*).
- Only genuine QUANTECH approved spare parts, oils, coolants, and refrigerants must be used.

- All the scheduled maintenance operations detailed in this manual must be performed at the specified times by suitably trained and qualified personnel (see SECTION 10 – MAINTENANCE).
- Failure to satisfy any of these conditions will automatically void the warranty (see Warranty Policy).

## SAFETY AND QUALITY

### Standards for Safety and Quality

QCC2 UNITS are designed and built within an ISO 9002 accredited design and manufacturing organization. The condensing units comply with the applicable sections of the following Standards and Codes:

- ANSI/ASHRAE Standard 15- Safety Code for Mechanical Refrigeration.
- ANSI/NFPA Standard 70- National Electrical Code (N.E.C.).
- ASME Boiler and Pressure Vessel Code- Section VIII Division 1.
- ARI Standard 550/590 - Positive Displacement Compressors and Air Cooled Rotary Screw Water Chilling Packages.
- ASHRAE 90.1- Energy Efficiency compliance.
- ARI 370- Sound Rating of Large Outdoor Refrigeration and Air Conditioning Equipment.
- Conform to Intertek Testing Services, formerly ETL, for construction of condensing units and provide E.T.L./c E.T.L. Listing label.

In addition, the condensing units conform to Underwriters Laboratories (U.L.) for construction of chillers and provide U.L./cU.L. Listing Label.

### Responsibility for Safety

Every care has been taken in the design and manufacture of the unit to ensure compliance with the safety requirements listed above. However, the individual operating or working on any machinery is primarily responsible for:

- Personal safety, safety of other personnel, and the machinery.
- Correct utilization of the machinery in accordance with the procedures detailed in the manuals.

## ABOUT THIS MANUAL

The following terms are used in this document to alert the reader to areas of potential hazard.



**A WARNING is given in this document to identify a hazard, which could lead to personal injury. Usually an instruction will be given, together with a brief explanation and the possible result of ignoring the instruction.**

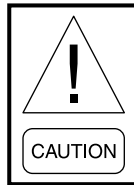

**A CAUTION identifies a hazard which could lead to damage to the machine, damage to other equipment and/or environmental pollution. Usually an instruction will be given, together with a brief explanation and the possible result of ignoring the instruction.**

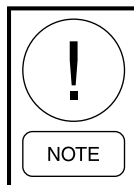

**A NOTE is used to highlight additional information, which may be helpful to you but where there are no special safety implications.**

The contents of this manual include suggested best working practices and procedures. These are issued for guidance only, and they do not take precedence over the above stated individual responsibility and/or local safety regulations.

This manual and any other document supplied with the unit are the property of Quantech which reserves all rights. They may not be reproduced, in whole or in part, without prior written authorization from an authorized Quantech Sales Representative.

## MISUSE OF EQUIPMENT

### Suitability for Application

The unit is intended for DX cooling applications and is not suitable for purposes other than those specified in these instructions. Any use of the equipment other than its intended use, or operation of the equipment contrary to the relevant procedures may result in injury to the operator, or damage to the equipment.

The unit must not be operated outside the design parameters specified in this manual.

## Structural Support

Structural support of the unit must be provided as indicated in these instructions. Failure to provide proper support may result in injury to the operator, or damage to the equipment and/or building.

## Mechanical Strength

The unit is not designed to withstand loads or stresses from adjacent equipment, pipework or structures. Additional components must not be mounted on the unit. Any such extraneous loads may cause structural failure and may result in injury to the operator, or damage to the equipment.

## General Access

There are a number of areas and features, which may be a hazard and potentially cause injury when working on the unit unless suitable safety precautions are taken. It is important to ensure access to the unit is restricted to suitably qualified persons who are familiar with the potential hazards and precautions necessary for safe operation and maintenance of equipment containing high temperatures, pressures and voltages.

## Pressure Systems

The unit contains refrigerant vapor and liquid under pressure, release of which can be a danger and cause injury. The user should ensure that care is taken during installation, operation and maintenance to avoid damage to the pressure system. No attempt should be made to gain access to the component parts of the pressure system other than by suitably trained and qualified personnel.

## Electrical

The unit must be grounded. No installation or maintenance work should be attempted on the electrical equipment without first switching power OFF, isolating and locking-off the power supply. Servicing and maintenance on live equipment must only be performed by suitably trained and qualified personnel. No attempt should be made to gain access to the control panel or electrical enclosures during normal operation of the unit.

## Rotating Parts

Fan guards must be fitted at all times and not removed unless the power supply has been isolated. If ductwork is to be fitted, requiring the wire fan guards to be removed, alternative safety measures must be taken to protect against the risk of injury from rotating fans.

## Sharp Edges

The fins on the air-cooled condenser coils have sharp metal edges. Reasonable care should be taken when working in contact with the coils to avoid the risk of minor abrasions and lacerations. The use of gloves is recommended.

Frame rails, brakes, and other components may also have sharp edges. Reasonable care should be taken when working in contact with any components to avoid risk of minor abrasions and lacerations.

## Refrigerants and Oils

Refrigerants and oils used in the unit are generally non-toxic, non-flammable and non-corrosive, and pose no special safety hazards. Use of gloves and safety glasses is, however, recommended when working on the unit. The buildup of refrigerant vapor, from a leak for example, does pose a risk of asphyxiation in confined or enclosed spaces and attention should be given to good ventilation.

## High Temperature and Pressure Cleaning

High temperature and pressure cleaning methods (e.g. steam cleaning) should not be used on any part of the pressure system as this may cause operation of the pressure relief device(s). Detergents and solvents, which may cause corrosion, should also be avoided.

## Emergency Shutdown

In case of emergency, the control panel is fitted with a Unit Switch to stop the unit in an emergency. When operated, it removes the low voltage 120 VAC electrical supply from the inverter system, thus shutting down the unit.

THIS PAGE INTENTIONALLY LEFT BLANK



## SECTION 2 – PRODUCT DESCRIPTION

### INTRODUCTION

Quantech Series 40 Air-Cooled Scroll Condensing Units provide chilled water for all air conditioning applications using central station air handling or terminal units. They are completely self-contained and are designed for outdoor (roof or ground level) installation. Each unit includes hermetic scroll compressors, a liquid cooler, air cooled condenser, and a weather resistant microprocessor control center, all mounted on a pressed steel base.

The units are completely assembled with all interconnecting refrigerant piping and internal wiring, ready for field installation.

The unit is pressure-tested, evacuated and given a nitrogen holding charge and includes an initial oil charge (R-410A refrigerant supplied by others). After assembly, a operational test is performed to assure that each control device operates correctly.

The unit structure is heavy-gauge, galvanized steel. This galvanized steel is coated with baked-on powder paint which, when subjected to ASTM B117 1000 hour, salt spray testing, yields a minimum ASTM 1654 rating of “6”. Units are designed in accordance with NFPA 70 (National Electric Code), ASHRAE/ANSI 15 Safety code for mechanical refrigeration, and are cETL listed. All units are produced at an ISO 9000-registered facility.

All exposed power wiring is routed through liquid-tight, non-metallic conduit.

### GENERAL SYSTEM DESCRIPTION

#### Compressors

The condensing unit has suction-gas cooled, hermetic, scroll compressors. The QCC2 compressors incorporate a compliant scroll design in both the axial and radial direction. All rotating parts are statically and dynamically balanced. A large internal volume and oil reservoir provides greater liquid tolerance. Compressor crankcase heaters are also included for extra protection against liquid migration.

An annular discharge check valve and reverse vent assembly provides low pressure drop, silent shutdown, and reverse rotation protection.

#### Condenser

**Coils** – Fin and tube condenser coils of seamless, internally-enhanced, high-condensing-coefficient, corrosion resistant copper tubes are arranged in staggered rows, mechanically expanded into aluminum fins. Integral subcooling is included. The design working pressure of the coil is 650 PSIG (45 bar).



**FIGURE 1 - QUANTECH AIR-COOLED SCROLL COMPRESSOR CONDENSING UNIT**

**Low Sound Fans**

The condenser fans are composed of corrosion resistant aluminum hub and composite blades molded into a low noise airfoil section. They are designed for maximum efficiency and are statically and dynamically balanced for vibration-free operation. They are directly driven, and positioned for vertical air discharge. The fan guards are constructed of heavy-gauge, rust-resistant, PVC (polyvinyl chloride)-coated steel wire.

**Motors**

The fan motors are Totally Enclosed Air-Over, squirrel-cage type, current protected. They feature ball bearings that are double-sealed and permanently lubricated.

**MICROCOMPUTER CONTROL CENTER**

All controls are contained in a NEMA 3R/12 cabinet with hinged outer door and include Liquid Crystal Display (LCD) with Light Emitting Diode (LED) back-lighting for outdoor viewing and includes:

- Two display lines
- Twenty characters per line

**Display/Print**

Color coded 12-button non-tactile keypad with sections for display and print of typical information:

- Suction temperatures (optional)
- Ambient temperature
- System pressures (each circuit)
- Operating hours and starts (each compressor)
- Print calls up to the liquid crystal display
- Operating data for the systems
- History of fault shutdown data for up to the last six fault shutdown conditions.
- An RS-232 port, in conjunction with the press-to-print button, is provided to allow hard copy print-outs via a separate printer (by others).

**Entry**

This section is used to enter setpoints or modify system values.

**Setpoints**

Updating can be performed to:

- Suction pressure setting
- Suction pressure control zone
- Remote reset temperature range
- Set daily schedule/holiday for start/stop
- Manual override for servicing
- Low and high ambient cutouts
- Number of compressors
- Low suction pressure cutout
- High discharge pressure cutout
- Anti-recycle timer (compressor start cycle time)
- Anti-coincident timer (delay compressor starts)

**Unit**

This section is used to:

- Set clock
- Set options
- Set unit option

Set unit control for Discharge Air Temperature Control or for Suction Pressure Control (requires Suction Pressure Transducers) is standard.

**Unit On/Off Switch**

The microprocessor control center is capable of displaying the following:

- Suction temperatures (optional)
- Low ambient temperature cutout setting
- English or Metric data
- Suction pressure cutout setting
- Each system suction pressure
- System discharge pressure

- Discharge Air Temperature Reset via a ISN DDC or Building Automation System (by others) via:
  - a pulse width modulated (PWM) input as standard
  - a 4 to 20ma or 0 to 10VDC input, or contact closure with the optional B.A.S. interface option
- Anti-recycle timer status for each system
- Anti-coincident system start timer condition
- Compressor run status
- No cooling load condition
- Day, date and time
- Daily start/stop times
- Holiday status
- Automatic or manual system lead/lag control (Discharge Air Temperature control only)
- Automatic lead/lag of compressors within a system
- Compressor starts and operating hours (each compressor)
- Status of hot gas valves, and fan operation
- Run permissive status
- Number of compressors running
- Liquid solenoid valve status
- Load and unload timer status

Provisions are included for pumpdown at shutdown, optional remote discharge air temperature reset, and two steps of demand load limiting from an external building automation system. Unit alarm contacts are standard.

The operating program is stored in non-volatile memory (EPROM) to eliminate condensing unit failure due to AC powered failure/battery discharge. Programmed setpoints are retained in lithium battery -backed RTC memory for 5 years minimum.

## **BUILDING AUTOMATION SYSTEM INTERFACE**

The Microprocessor Board can accept a 4 to 20ma, 0 to 10VDC or contact closure input to reset the discharge air temperature from a Building Automation System. Only one of the following remote communications options can be offered on a unit at a time: BAS Interface, Remote Control Panel or Multi-unit Sequence Control (Factory Mounted).

- The standard unit capabilities include remote start-stop, remote water temperature reset via a PWM 4 to 20ma or 0 to 10VDC input signal or up to two stages of demand (load) limiting depending on model.
- The standard control panel can be directly connected to a Quantech Building Automated System.

## **COMMUNICATIONS**

- Native communication capability for BACnet (MS/TP) and Modbus
- Optional communication available for N2 and LON via eLink option

## **POWER PANEL**

Each panel contains:

- Compressor power terminals
- Compressor motor starting contactors per International Electrotechnical Commission (I.E.C.).
- Control power terminals to accept incoming for 115-1-60 control power
- Fan contactors and overload current protection

The power wiring is routed through liquid-tight conduit to the compressors and fans.

## ACCESSORIES AND OPTIONS

### Electrical Options

#### **Compressor Power Connections**

Single-point terminal block connection(s) are provided as standard. The following power connections are available as factory mounted options. (See Electrical Data for specific voltage and options availability.)

#### **Single-Point Supply Terminal Block (Standard on QCC2 Models).**

Includes enclosure, terminal-block and interconnecting wiring to the compressors. Separate external protection must be supplied, by others, in the incoming compressor-power wiring. This option cannot be included if either the Single Point Non-Fused Disconnect Switch or Single-Point Circuit Breaker options have been included.

#### **Single-Point Non-Fused Disconnect Switch**

Unit-mounted disconnect switch with external, lockable handle in compliance with Article 440-14 of N.E.C., can be supplied to isolate the unit power voltage for servicing. Separate external fusing must be supplied, by others in the power wiring, which must comply with the National Electrical Code and/or local codes.

#### **Single-Point Circuit Breaker**

A unit mounted circuit breaker with external, lockable handle (in compliance with N.E.C. Article 440-14), can be supplied to isolate the power voltage for servicing. (This option includes the Single-Point Power connection.)

#### **Control Transformer**

This transformer converts unit power voltage to 115-1-60 (0.5 or 1.0 KVA capacity). Factory mounting includes primary and secondary wiring between the transformer and the control panel.

#### **Power Factor Correction Capacitors**

These factory mounted capacitors will correct unit compressor to a power factor between 0.90 and 0.95.

### Control Options

#### **Ambient Kit (Low)**

Units will operate to 25°F (-4°C). This factory mounted accessory includes all necessary components to permit chiller operation to 0°F (-18°C). This option includes the Discharge Pressure Transducer / Readout Capability option. For proper head pressure control in applications below 25°F (-4°C), where wind gusts may exceed five mph, it is recommended that factory mounted optional Condenser Louvered Enclosure Panels also be included.

#### **Ambient Kit (High)**

This factory mounted kit is required if units are to operate when the ambient temperature is above 110°F (43°C) and includes discharge pressure transducers. This option includes the factory mounted Discharge Pressure Transducer / Readout Capability option.

#### **Building Automation System Interface**

The factory addition of a Printed Circuit Board to accept a 4 to 20ma, 0 to 10VDC or contact closure input to reset the leaving chiller liquid temperature from a Building Automation System. Only one of following options can be offered on a unit at a time: BAS, Remote Control Panel or Multi-unit Sequence Control. (Factory-Mounted) The standard unit capabilities include remote start/stop, remote water temperature reset via a PWM input signal or up to two steps of demand (load) limiting depending on model. The standard control panel can be directly connected to a Building Automated System via the standard onboard RS485 communication port.

#### **Language LCD and Keypad Display**

Spanish, French, and German unit LCD controls and keypad display are available; however the standard language is English.

#### **DISCHARGE PRESSURE TRANSDUCERS AND READOUT CAPABILITY**

The addition of factory mounted pressure transducers allows models to sense and display discharge pressure. This is recommended for brine chilling applications. This option is included with either the low or high ambient kits.

### **Suction Pressure Transducers**

This transducer permits the unit to sense and display suction pressure. This capability is standard on QCC2 models.

### **Motor Current Module**

This option allows the monitoring of compressor motor current and provides extra protection against compressor reverse rotation, phase-loss and phase imbalance. This factory mounted option consists of one module per electrical system.

### **Multi-Unit Sequencing**

A separate sequencing control center is provided to handle sequencing control of up to eight chillers in parallel based on mixed liquid temperature (interconnecting wiring by others). The only one of following factory mounted options can be offered on a unit at a time: BAS, Remote Control Panel or Multi-Unit Sequence Control.

### **Compressor and Piping Options**

#### **Chicago Code Relief Valves**

Unit will be provided with relief valves to meet Chicago code requirements. (Factory-Mounted)

#### **Service Isolation Valve**

Service isolation valves are standard to unit. This includes a system high pressure relief valve or internal compressor relief mechanism in compliance with ASHRAE 15. (Factory-Mounted)

#### **Hot Gas By-Pass**

Permits continuous, stable operation at capacities below the minimum step of compressor unloading to as low as 5% capacity (depending on both the unit and operating conditions) by introducing an artificial load on the cooler. Hot gas by-pass is installed on only refrigerant system #1 on two-circuited units. (Factory-Mounted)

### **Condenser and Cabinet Options**

Condenser coil protection against corrosive environments is available by choosing any of the following options. *For additional application recommendations, refer to Form 150.12-ES1.* (Factory-Mounted)

### **Pre-Coated Fin Condenser Coils**

The unit's coils are constructed with epoxy coated aluminum fins. This can provide corrosion resistance comparable to copper-fin coils in typical seashore locations. Either these or the post-coated coils (below) are recommended for units being installed at the seashore or where salt spray may hit the unit.

### **Post-Coated Dipped Condenser Coils**

The unit's coils are constructed with dipped-cured condenser coils. This is the choice for corrosive applications (with the exception of strong alkalis, oxidizers and wet bromine, chlorine and fluorine in concentrations greater than 100 ppm).

### **Copper Fin Condenser Coils**

The unit's coils are constructed with copper fins. (This is not recommended for units in areas where they may be exposed to acid rain.)

### **Enclosure Panels (Unit)**

Tamperproof enclosure panels prevent unauthorized access to units. Enclosure panels can provide an aesthetically pleasing alternative to expensive fencing. Additionally, for proper head pressure control, Quantech recommends the use of louvered panels.

### **Louvered Panels (Full Unit)**

Louvered panels surround the front, back, and sides of the unit. They prevent unauthorized access and visually screen unit components. Unrestricted air flow is permitted through generously sized louvered openings. This option is applicable for any outdoor design ambient temperature up to 115°F (46°C). (Factory-Mounted.)

### **Sound Attenuation**

One or both of the following factory mounted sound attenuation options are recommended for residential or other similar sound-sensitive locations. Louvered Panels can be ordered for winter applications where wind gusts may exceed five miles per hour. The following types of enclosure options are available:

**Compressor Acoustic Sound Blanket**

Each factory mounted compressor is individually enclosed by an acoustic sound blanket. The sound blankets are made with one layer of acoustical absorbent textile fiber of 5/8” (15mm) thickness; one layer of anti-vibrating heavy material thickness of 1/8” (3mm). Both are closed by two sheets of welded PVC, reinforced for temperature and UV resistance.

**Ultra Quiet Fan**

Lower RPM, 8-pole fan motors are used with steeper-pitch fans on these factory mounted devices.

**Vibration Isolators**

Level adjusting, spring type 1” (25.4mm) or seismic deflection or neoprene pad isolators for mounting under unit base rails. (Field-Mounted)

**UNIT COMPONENTS**

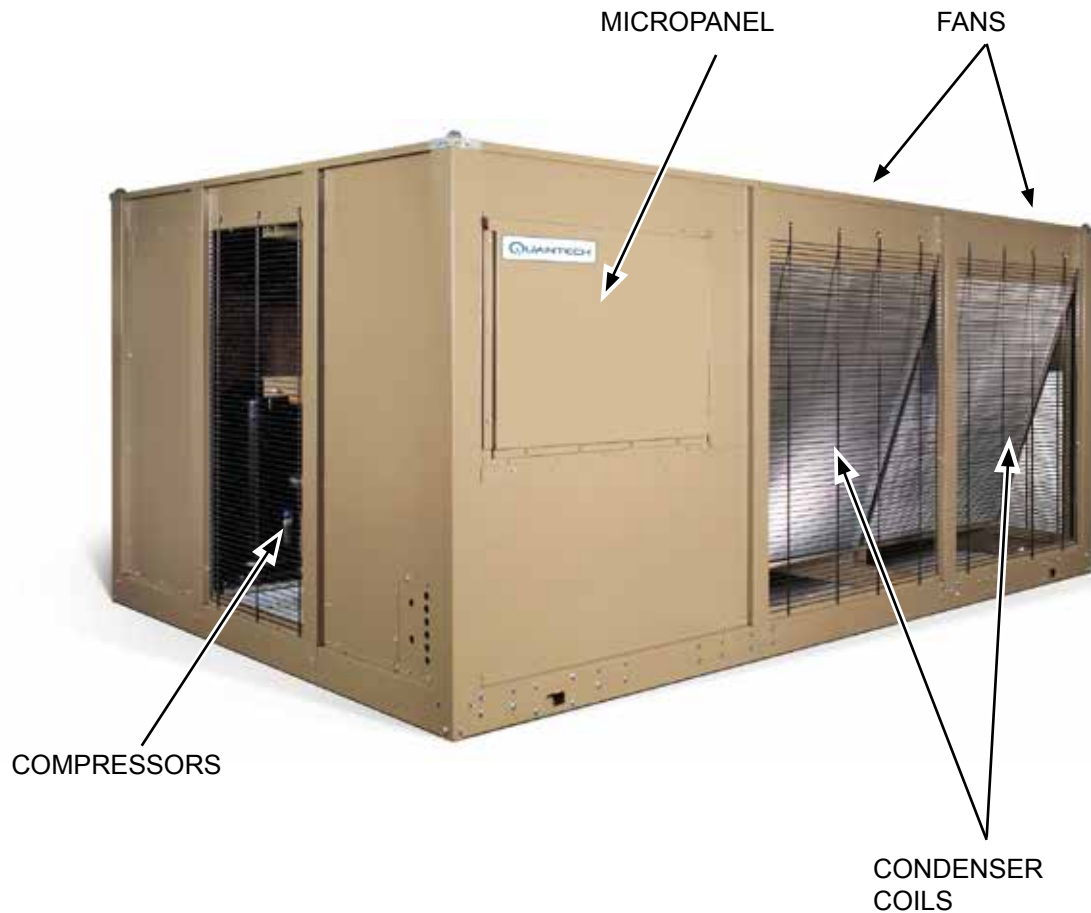

**FIGURE 2 - UNIT COMPONENTS FRONT**

### POWER PANEL COMPONENTS

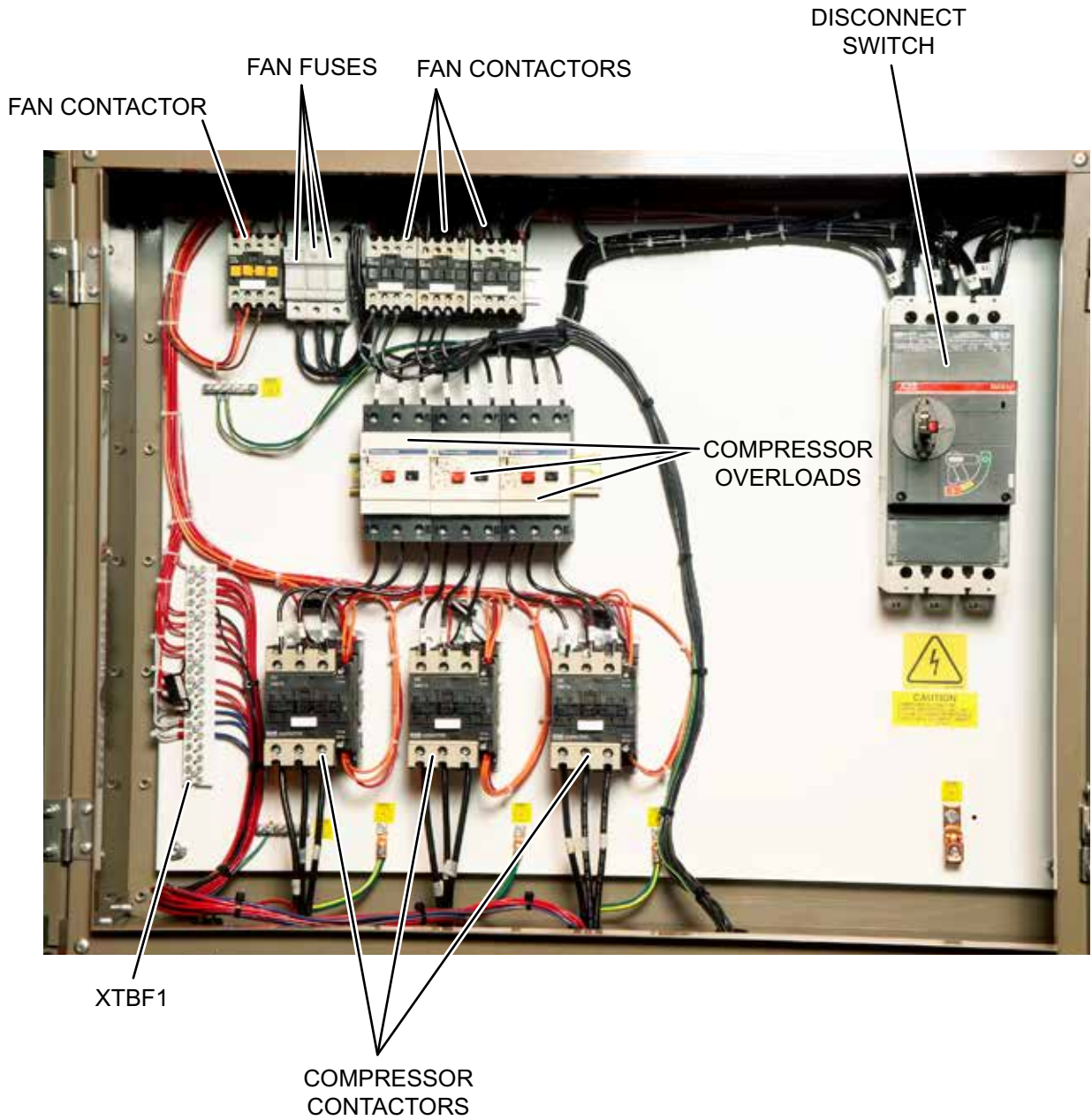

LD13247

FIGURE 3 - POWER PANEL COMPONENTS



## POWER PANEL / CONTROL COMPONENTS

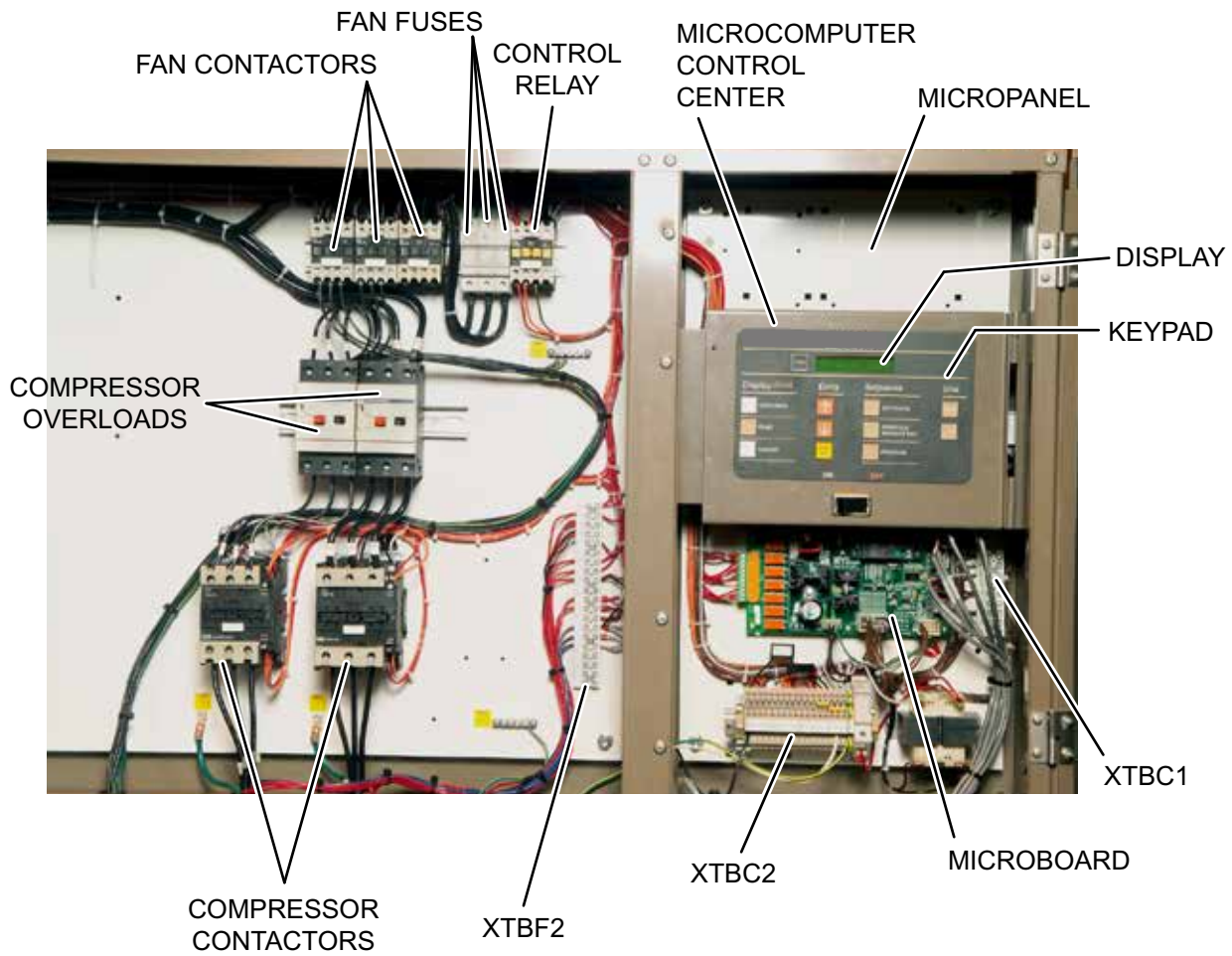

LD13248

**FIGURE 4 - POWER PANEL / CONTROL COMPONENTS**



## PRODUCT IDENTIFICATION NUMBER (PIN)

### BASIC UNIT

### BASIC MODEL NUMBER

# QCC2040CEE46XEA

**1 2 3 4**  
BASE PRODUCT TYPE

↓  
2 : Scroll

↓  
C : Unit

QC : Quantech Air-Cooled  
Scroll Condensing Units

**0 4 0 C**  
NOMINAL CAPACITY

↓ ↓ ↓ ↓  
Nominal Capacity

**9**  
UNIT DESIGNATOR

↓  
E : High Efficiency

**10**  
REFRIGERANT

↓  
E : R-410A

**11 12 13**  
VOLTAGE/STARTER

↓ ↓ ↓  
X : Across the Line

1 7 :200 / 3 / 60  
2 8 :230 / 3 / 60  
4 0 :380 / 3 / 60  
4 6 :460 / 3 / 60  
5 8 :575 / 3 / 60  
5 0 :380-415 / 3 / 50

**14 15**  
DESIGN/DEVELOPMENT LEVEL

↓  
A : Engineering Change  
or PIN Level

↓  
E : Design Series

FEATURE	FEATURE DESCRIPTION	OPTION	OPTION DESCRIPTION
MODEL	Model (PIN 1-4)	QCC2	QCC2
CAP	Capacity (PIN 5-8)	015C	015C
		020C	020C
		025C	025C
		030C	030C
		040C	040C
		045C	045C
		050C	050C
		060C	060C
		070C	070C
UNIT	Unit Designator (PIN 9)	E	High Efficiency
REF	Refrigerant (PIN 10)	E	R-410A
VOLTS	Voltage (PIN 11 & 12)	17	200/3/60
		28	230/3/60
		40	380/3/60
		46	460/3/60
		50	380-415/3/50
		58	575/3/60
STARTER	Starter (PIN 13)	X	Across The Line Starter
DESIGN	Design Series (PIN 14)	E	Design Series E
DEV	Development Level (PIN 15)	A	Development Level A
POWER	Power Field (PIN 16 & 17)	SX	Single Point Terminal Block
		SD	Single Point Non-Fused Disconnect
		BX	Single Point Circuit Breaker
		QQ	Special Power Option Required
TRANS	Cntrl Transformer (PIN 18)	X	No Control Transformer Required
		T	Control Transformer Required
		Q	Special Control Transformer Required

**PRODUCT IDENTIFICATION NUMBER (PIN) (CONT'D)**

FEATURE	FEATURE DESCRIPTION	OPTION	OPTION DESCRIPTION
PFC	Power Factor Capacitor (19)	X	No Power Capacitor Required
		C	Power Capacitor Required
		Q	Special Power Capacitor Required
AMB	Ambient Kits (PIN 20)	H	High Ambient (standard)
		A	Both Low And High Ambient (Low Ambient kit required)
		Q	Special Ambient Kit Required
BAS	Bas Reset/Offset (PIN 21)	X	No BAS Reset/Offset Required
		M	ISN Microgateway Required
		T	BAS Reset/Offset Required
		Q	Special BAS Reset/Offset Required
LCD	Language (PIN 22)	X	English
		S	Spanish
		F	French
		G	German
		Q	Special Language Required
RDOUT	Readout Kits (PIN 23)	R	Discharge Pressure Readout (standard)
		Q	Special Pressure Readout Required
SAFETY	Safety Codes (PIN 24)	L	N American Safety Code (cUL/cETL)
SENSOR	PIN 25	X	No Option Required
		Q	Special Quote
PUMP	Motor Current Module (PIN 26)	X	No Motor Current Readout Required
		C	Motor Current Readout
		Q	Special Quote
REMOTE	Remote Panel (PIN 27)	X	No Remote Panel Required
		O	Opiview Remote Panel Required
		Q	Special Remote Panel Required
SEQ	Sequence Kit (PIN 28)	X	No Sequence Kit Required
		S	Sequence Kit Required = {SEQ/S}
		Q	Special Sequence Kit Required
TEMP	Suction Temp (PIN 29,30)	NUM	Suction Temp = {TEMP/NUM} Degrees
		QQ	Special LWT Requirements
CHICAGO	Chicago Code Kit (PIN 31)	X	Service Isolation Valves
		B	Both Chicago Code and Serv Isolation
		Q	Special Chicago Code Kit Required
VALVES	Valves (PIN 32)	X	Standard Valves Req'd
		Q	Special Optional Valves Req'd
HGBP	Hot Gas Bypass (PIN 33)	X	No Hot Gas Bypass Required
		1	Hot Gas Bypass Required - 1 Circuit
		2	Hot Gas Bypass Required - 2 Circuits
		Q	Special Hot Gas Bypass Required
GAUGE	PIN 34	X	No Option Required
		Q	Special Quote
OVERLOAD	PIN 35	X	No Option Required
		Q	Special Quote

## PRODUCT IDENTIFICATION NUMBER (PIN) (CONT'D)

FEATURE	FEATURE DESCRIPTION	OPTION	OPTION DESCRIPTION
PIN 36	PIN 36	X	No Option Required
		Q	Special Quote
HTR	Crankcase Heater (Pin 37)	X	Crankcase Heater Standard
		Q	Special Crankcase Heater Required
DWP	DWP (PIN 38)	X	No Option Required
		Q	Special Quote
INS	Insulation (PIN 39)	X	No Option Required
		Q	Special Quote
FLANGES	Flanges (PIN 40)	X	No Option Required
		Q	Special Quote
FLOW	Flow Switch (PIN 41)	X	No Option Required
		Q	Special Quote
VESSEL	Vessel Codes (PIN 42)	X	No Option Required
		Q	Special Quote
CLR	Cooler (PIN 43)	X	No Option Required
		Q	Special Quote
PIN44	PIN 44	X	No Option Required
		Q	Special Quote
COILS	Coils (PIN 45)	X	Aluminum Coil
		B	Pre-Coated Fin Coil
		C	Copper Coil
		P	Post-Coated Dipped Coil
		Q	Special Coil
PIN46	PIN 46	X	No Option Required
		Q	Special Quote
FANMOTORS	Fan Motors (PIN 47)	X	TEAO Fan Motors
		Q	Special Fan Motors Required
ENCL	Enclosure Panels (PIN 48)	1	Wire Enclosures - Factory
		7	Louvered Enclosure - Factory
		Q	Special Enclosure Panels
ACOUSTIC	Acoustic Blanket (PIN 49)	X	No Acoustic Blanket Required
		B	Acoustic Blanket Required
		Q	Special Acoustic Blanket Required
SRDOCS	SR Documents (PIN 50)	X	No Documents Required
		A	Base, Material and Witness Documents
		B	Base Document
		M	Base and Material Documents
		W	Base and Witness Documents
		Q	Special Quote
PIN51	PIN 51	X	No Option Required
		Q	Special Quote
FANS	Sound Fans (PIN 52)	X	Standard Low Sound Fans Required
		L	Ultra Low Sound Fans Required
		Q	Special Sound Fans Required

2

**PRODUCT IDENTIFICATION NUMBER (PIN) (CONT'D)**

FEATURE	FEATURE DESCRIPTION	OPTION	OPTION DESCRIPTION
PAINT	PIN 53	X	No Option Required
		Q	Special Quote
ISOL	Vibration Isolators (PIN 54)	X	No Isolators Required
		1	1" Deflection Isolators Required
		N	Neoprene Isolators Required
		S	Seismic Isolators Required
		Q	Special Isolators Required
WARRANTY	Warranty (PIN 55)		Marketing Purposes Only!
REFWTY	Refrigerant Wty (PIN 56)		Marketing Purposes Only!
SHIP	Ship Instructions (PIN 57)	X	No Containerization required
		A	Buy American Act Compliance
		B	Both Buy American Act Compliance and Container Shipping Kit (Factory Prep)
		C	Container Shipping Kit (Factory Load)
		P	Container Shipping Kit (Factory Prep)
		Q	Special Quote
PIN 58	PIN 58		Marketing Purposes Only!
PKG	Pump package (PIN 59)	X	No Option Required
		Q	Special Quote
PKGOPT	Pump Package Options (PIN 60)	X	No Option Required
		Q	Special Quote
MFG	Plant of Mfg (PIN 61)	R	Plant Of Manufacture - Monterrey
LOC	Mfg location	CUR	Curitiba, Brazil
		MEX	Mexico, ES
		MTY	Monterrey, BE
		SAT	San Antonio, Texas
YW	YorkWorks version	CV	Yorkworks Configuration Version {YW/CV}
		UV	Yorkworks Upload Version {YW/UV}
SQ	Special quote	Q	Special Quote

# REFRIGERANT FLOW DIAGRAM

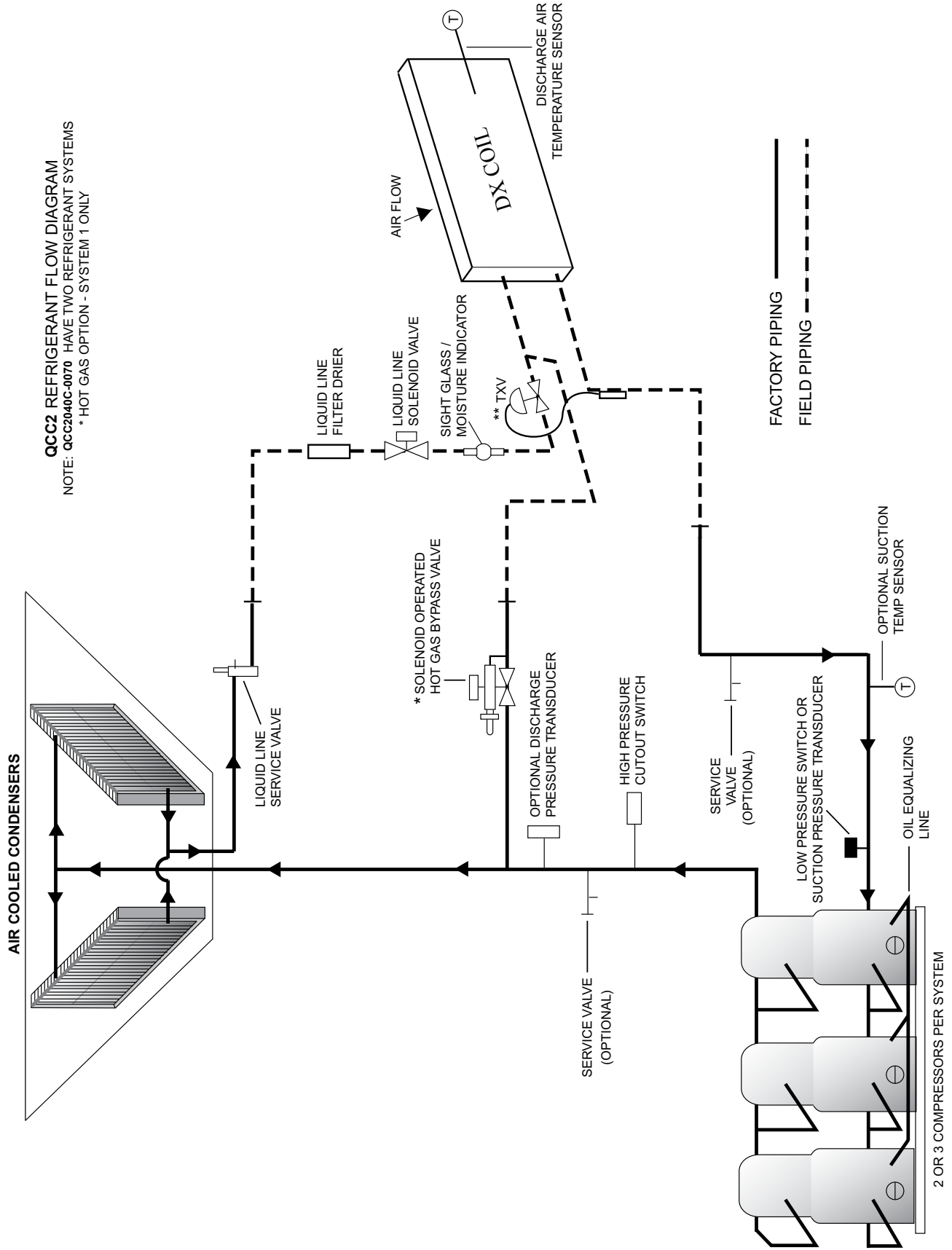

\*\*One TXV and Liquid Line Solenoid shown for illustration purposes. Actual refrigerant piping may vary depending on evaporator circuiting.

FIGURE 5 - REFRIGERANT FLOW DIAGRAM

LD04284A

### PROCESS AND INSTRUMENTATION DIAGRAM

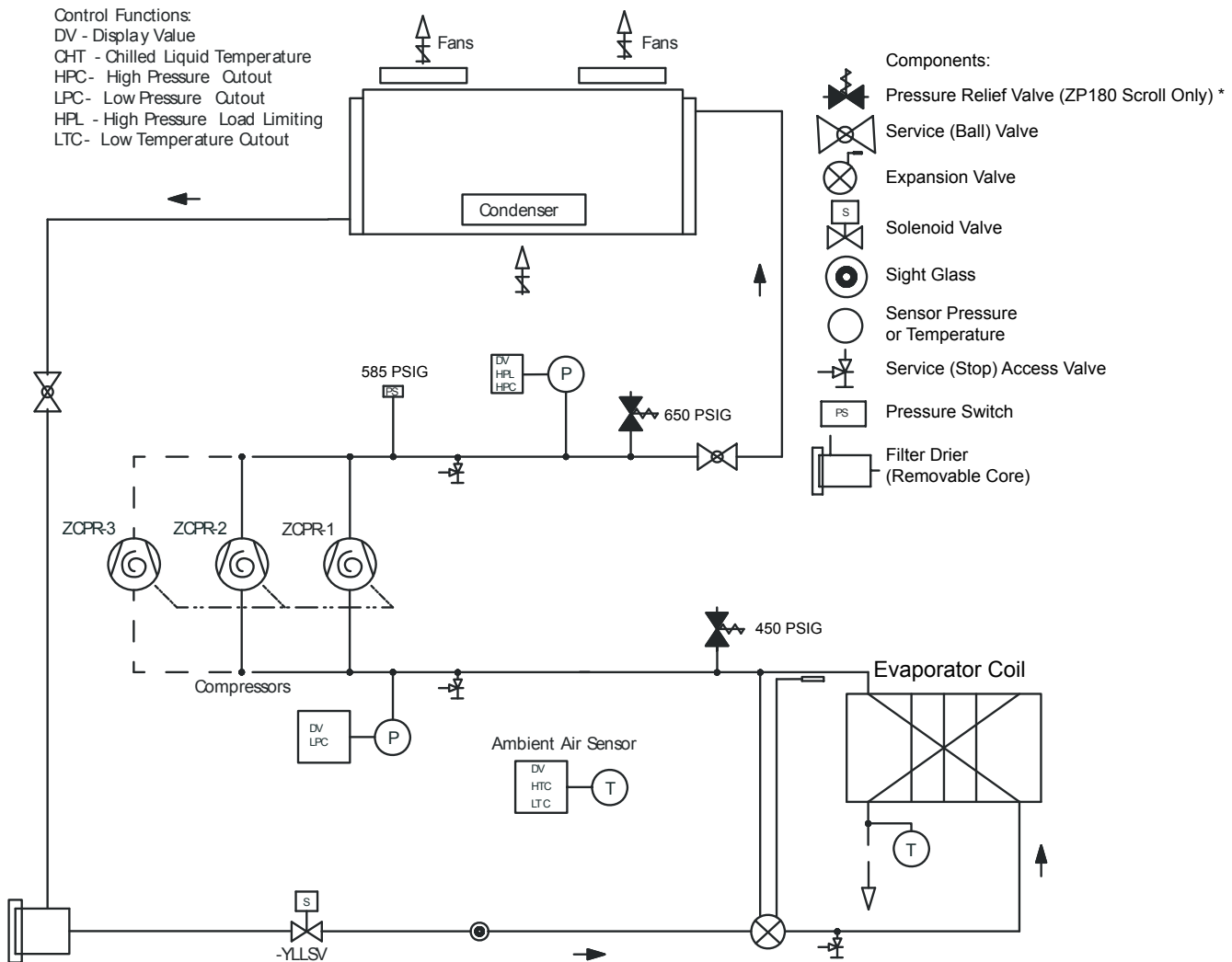

\* Smaller Compressor Scrolls Utilize Internal Reliefs.

LD13139

**FIGURE 6 - PROCESS AND INSTRUMENTATION DIAGRAM**

Low pressure liquid refrigerant enters the cooler and is evaporated and superheated by the heat energy absorbed from the chilled liquid passing through the cooler shell. Low pressure vapor enters the compressor where pressure and superheat are increased. The

high pressure vapor is fed to the air cooled condenser coil and fans where the heat is removed. The fully condensed and subcooled liquid passes through the expansion valve where pressure is reduced and further cooling takes place before returning to the DX Coil.

## SECTION 3 – HANDLING AND STORAGE

### DELIVERY AND STORAGE

To ensure consistent quality and maximum reliability, all units are tested and inspected before leaving the factory. Units are shipped completely assembled and containing refrigerant under pressure. Units are shipped without export crating unless crating has been specified on the Sales Order.

If the unit is to be put into storage, prior to installation, the following precautions should be observed:

- The unit must be “blocked” so that the base is not permitted to sag or bow.
- Ensure that all openings, such as water connections, are securely capped.
- Do not store where exposed to ambient air temperatures exceeding 110 °F (43 °C).
- The condensers should be covered to protect the fins from potential damage and corrosion, particularly where building work is in progress.
- The unit should be stored in a location where there is minimal activity in order to limit the risk of accidental physical damage.
- To prevent inadvertent operation of the pressure relief devices the unit must not be steam cleaned.
- It is recommended that the unit is periodically inspected during storage.

### INSPECTION

Immediately upon receiving the unit, it should be inspected for possible damage which may have occurred during transit. If damage is evident, it should be noted in the carrier’s freight bill. A written request for inspection by the carrier’s agent should be made at once. See “Instruction” manual, Form 50.15-NM for more information and details.

Major damage must be reported immediately to your local Quantech Sales Representative.

### UNIT RIGGING

Use spreader bars to avoid lifting chains hitting the unit.

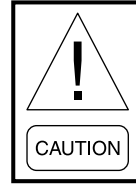

***Never lift the unit using a forklift or by hooking to the top rails. Use only the lifting holes provided.***

Lifting Instructions are placed on a label on the unit and on the shipping bag.



***The unit should be lifted by inserting hooks through the holes provided in unit base rails. Spreader bars should be used to avoid crushing the unit frame rails with the lifting chains (See Figure 7).***

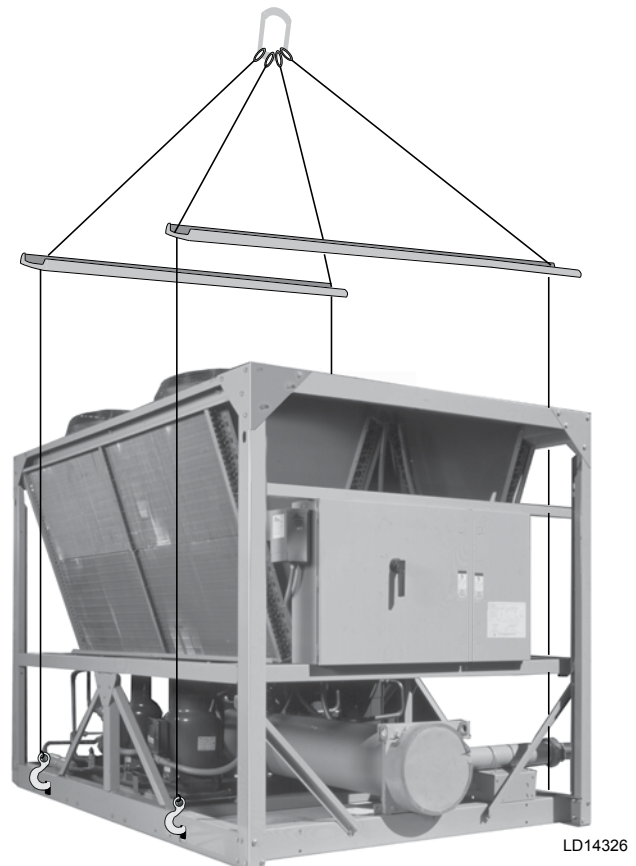

LD14326

**FIGURE 7 - UNIT RIGGING**

### Moving the Condensing Unit

Prior to moving the unit, ensure that the installation site is suitable for installing the unit and is easily capable of supporting the weight of the unit and all associated services.

The units are designed to be lifted using cables. A spreader bar or frame should be used in order to prevent damage to the unit from the lifting chains.

Units are provided with lifting eyes in the sides of the base frame, which can be attached to directly using shackles or safety hooks.



***The unit must only be lifted by the base frame at the points provided. Never move the unit on rollers, or lift the unit using a forklift truck.***

Care should be taken to avoid damaging the condenser cooling fins when moving the unit.

### Lifting Weights

For details of weights and weight distribution, *refer to the data shipped in the unit information packet and unit nameplate.*



## SECTION 4 – INSTALLATION



***To ensure warranty coverage, this equipment must be commissioned and serviced by an authorized Quantech service mechanic or a qualified service person experienced in equipment installation. Installation must comply with all applicable codes, particularly in regard to electrical wiring and other safety elements such as relief valves, HP cutout settings, design working pressures, and ventilation requirements consistent with the amount and type of refrigerant charge.***

***Lethal voltages exist within the control panels. Before servicing, open and lock-out/tagout all disconnect switches.***

### INSTALLATION CHECKLIST

The following items, 1 through 5, must be checked before placing the units in operation.

1. Inspect the unit for shipping damage.
2. Rig unit using spreader bars.
3. Open the unit only to install water piping system. Do not remove protective covers from water connections until piping is ready for attachment. Check water piping to ensure cleanliness.
4. Pipe unit using good piping practice (*see ASHRAE handbook section 215 and 195*).
5. Check to see that the unit is installed and operated within limitations (*Refer to Limitations*).

The following pages outline detailed procedures to be followed to install and start-up the unit.

### HANDLING

These units are shipped as completely assembled units containing full operating charge, and care should be taken to avoid damage due to rough handling.

### LOCATION AND CLEARANCES

These units are designed for outdoor installations on ground level, rooftop, or beside a building. Location should be selected for minimum sun exposure and to insure adequate supply of fresh air for the condenser. The units must be installed with sufficient clearances for air entrance to the condenser coil, for air discharge away from the condenser, and for servicing access.

In installations where winter operation is intended and snow accumulations are expected, additional height must be provided to ensure normal condenser air flow.

Clearances are listed in the “Dimensions” section.

### Foundation

The unit should be mounted on a flat and level foundation, floor, or rooftop capable of supporting the entire operating weight of the equipment. *See Table 6 on page 40* for operating weight. If the unit is elevated beyond the normal reach of service personnel, a suitable catwalk must be capable of supporting service personnel, their equipment, and the compressors.

### Ground Level Locations

It is important that the units be installed on a substantial base that will not settle. A one piece concrete slab with footers extended below the frost line is highly recommended. Additionally, the slab should not be tied to the main building foundations as noise and vibration may be transmitted. Mounting holes are provided in the steel channel for bolting the unit to its foundation (*see Dimensions*).

For ground level installations, precautions should be taken to protect the unit from tampering by or injury to unauthorized persons. Screws and/or latches on access panels will prevent casual tampering. However, further safety precautions such as a fenced-in enclosure or locking devices on the panels may be advisable.

### Rooftop Locations

Choose a spot with adequate structural strength to safely support the entire weight of the unit and service personnel. Care must be taken not to damage the roof.

Consult the building contractor or architect if the roof is bonded. Roof installations should have wooden beams (treated to reduce deterioration), cork, rubber, or vibration isolators under the base to minimize vibration.

### Noise Sensitive Locations

Efforts should be made to assure that the unit is not located next to occupied spaces or noise sensitive areas where unit noise level would be a problem. Unit noise is a result of compressor and fan operation. Considerations should be made utilizing noise levels published in the Quantech Engineering Guide for the specific condensing unit model. Sound blankets for the compressors and low sound fans are available.

## Corrosive Environments

Protection against corrosive environments is available by supplying the units with either copper fin, cured phenolic, or epoxy coating on the condenser coils. The phenolic or epoxy coils should be offered with any units being installed at the seashore or where salt spray may hit the unit.

## SPRING ISOLATORS (OPTIONAL)

When ordered, four (4) isolators will be furnished. Identify the isolator, locate at the proper mounting point, and adjust per instructions.

## COMPRESSOR MOUNTING

The compressors are mounted on four (4) rubber isolators. The mounting bolts should not be loosened or adjusted at installation of the chiller.

## PIPEWORK ARRANGEMENT

The following are suggested pipework arrangements for single unit installations.

## DUCT WORK CONNECTION

### RECOMMENDATIONS OF THE BUILDING SERVICES RESEARCH ASSOCIATION.

#### General Requirements

The following duct work recommendations are intended to ensure satisfactory operation of the unit. Failure to follow these recommendations could cause damage to the unit, or loss of performance, and may invalidate the warranty.

When ducting is to be fitted to the fan discharge it is recommended that the duct should be the same cross-sectional area as the fan outlet and straight for at least three feet (1 meter) to obtain static regain from the fan. Duct work should be suspended with flexible hangers to prevent noise and vibration being transmitted to the structure. A flexible joint is also recommended between the duct attached to the fan and the next section for the same reason. Flexible connectors should not be allowed to concertina.

The unit(s) is not designed to take structural loading. No significant amount of weight should be allowed to rest on the fan outlet flange, deck assemblies or condenser coil module. No more than 3 feet (1 meter) of light construction duct work should be supported by the unit. Where cross winds may occur, any duct work must be supported to prevent side loading on the unit.

If the ducts from two or more fans are to be combined into a common duct, back-flow dampers should be fitted in the individual fan ducts. This will prevent recirculation of air when only one of the fans is running.

Units are supplied with outlet guards for safety and to prevent damage to the fan blades. If these guards are removed to fit duct work, adequate alternative precautions must be taken to ensure persons cannot be harmed or put at risk from rotating fan blades.

## WIRING

Condensing Units are shipped with all factory-mounted controls wired for operation.

### Field Wiring

Power wiring must be provided through a fused disconnect switch to the unit terminals (or optional molded disconnect switch) in accordance with N.E.C. or local code requirements. Minimum circuit ampacity and maximum dual element fuse size are given in Table 9.

Only copper power wiring should be used for supplying power to the unit. This is recommended to avoid safety and reliability issues resulting from connection failure at the power connections to the unit. Aluminum wiring is not recommended due to thermal characteristics that may cause loose terminations resulting from the contraction and expansion of the wiring. Aluminum oxide may also build up at the termination causing hot spots and eventual failure. If aluminum wiring is used to supply power to the unit, AL-CU compression fittings should be used to transition from aluminum to copper. This transition should be done in an external box separate to the power panel. Copper conductors can then be run from the box to the unit.

A 120-1-60, 15 amp source must be supplied for the control panel through a fused disconnect when a control panel transformer (optional) is not provided (*Refer to Figure 8*).

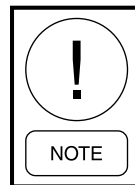

***See unit wiring diagrams for field and power wiring connections, alarm contacts, compressor run status contacts, PWM input, and load limit input. Refer to section on UNIT OPERATION for a detailed description of operation concerning aforementioned contacts and inputs.***

## System Run Contacts

Contacts are available to monitor system status. Normally-open auxiliary contacts from each compressor contactor are wired in parallel with XTBC2 – Terminals 25 to 26 for system 1, and XTBC2 – Terminals 27 to 28 for system 2. Refer to Figure 4 on page 20, Figure 10 on page 37 and the unit wiring diagrams starting on page 48.

## Alarm Status Contacts

Normally-open contacts are available for each refrigerant system. These normally-open contacts close when the system is functioning normally. The respective contacts will open when the unit is shut down on a unit fault, or locked out on a system fault. Field connections are at XTBC2 - Terminals 29 to 30 (system 1), and Terminals 31 to 32 (system 2).

## Remote Start/Stop Contacts

To remotely start and stop the chiller, dry contacts can be wired in series with the flow switch and XTBC1 - Terminals 13 to 51. Refer to Figure 4 on page 20, Figure 10 on page 37 and the unit wiring diagrams starting on page 48.

## Remote Emergency Cutoff

Immediate shutdown of the chiller can be accomplished by opening a field-installed dry contact to break the electrical circuit between Terminals 5 to L on Terminal Block XTBC2. The unit is shipped with a factory jumper installed between Terminals 5 to L, which must be removed if emergency shutdown contacts are installed. Refer to Figure 10 on page 37 and the unit wiring diagrams starting on page 48.

## Remote Temp Reset Input

The Remote Temp Reset input allows reset of the discharge air temperature setpoint by supplying a voltage or current signal field wiring should be connected to XTBC1 – Terminals A+ to A-. A detailed explanation is provided in the Unit Control section. Refer to Figure 3 on page 19, Figure 4 on page 20, and the unit wiring diagrams starting on page 48.

## Load Limit Input

Load limiting is a feature that prevents the unit from loading beyond a desired value. (The unit can be “load limited” either 33%, 40%, 50%, 66% or 80%, depending on the number of compressors on unit.) The field connections are wired to XTBC1 – Terminals 13 to 21,

and work in conjunction with the PWM inputs. A detailed explanation is provided in the Unit Control section. Refer to Figure 4 on page 20, Figure 10 on page 37 and the unit wiring diagrams starting on page 48.

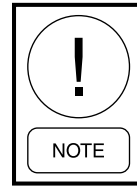

**When using the Load Limit feature, the PWM feature will not function – SIMULTANEOUS OPERATION OF LOAD LIMITING AND TEMPERATURE RESET (PWM INPUT) CANNOT BE DONE.**

## Liquid Line Solenoid Connections

The field supplied and installed liquid line solenoid valves should be installed at the evaporator and wired using 18 AWG minimum wire. Electrical connections should be made at Terminal Board TB1. TB1 is located in the power panel on the left side of the power panel. **Note that power for the solenoid coil is 120 VAC.** Refer to Figure 10 on page 37 and the unit wiring diagrams starting on page 48.

## Discharge Air Sensor

The discharge air sensor and associated connector hardware is factory supplied but must be field installed. Field wire must be field supplied (QUABBIN 930421-2 or equivalent 2 conductor with shield and drain wire - 20 AWG 300 V 60°C - polyethylene insulation UV resistant). Field wiring is connected to pins 2, 5, and 8 of J6 on the microboard. Refer to Figure 4 on page 20, and the unit wiring diagrams starting on page 48.

## Zone Thermostats, Suction Pressure Control Only (Remote Start/Stop)

Field supplied thermostats or dry contacts **must be field wired to start/stop the respective system when operating the unit in Suction Pressure Control Mode.** The System 1 zone thermostat is field wired at XTBC1 terminals 13 to 50. On two system units, System 2 zone thermostat is field wired to XTBC1 terminals 13 to 51. XTBC 1 terminal is located near the bottom of the micro control panel. Refer to Figure 4 on page 20, and the unit wiring diagrams starting on page 48.

## Air Proving Switch/Remote Start-Stop Contacts



***The Air Flow Switch MUST NOT be used to start and stop the chiller (i.e. starting and stopping the blower). It is intended only as a safety switch.***

The air proving switch is field wired to XTBC1 terminals 13 to 14 to prevent operation of the refrigerant circuit when the supply air blower is not operating.

If separate evaporator blowers are used with respect to each refrigerant system in the condensing unit, then two air proving switches (used for each blower) must be wired in series across XTBC1 terminals 13 - 14. Refer to Figure 10 on page 37 and the unit wiring diagrams starting on page 48.

## Evaporator Blower Start Contacts

For constant fan operation: Terminal block XTBC2 - terminals 23 to 24, are normally open contacts that can be used to switch field supplied power to provide a start signal to the evaporator blower contactor. Contacts will close whenever the daily schedule is programmed for cooling. Refer to Figure 10 on page 37 and the unit wiring diagrams starting on page 48.

## RELIEF VALVES

Relief valves are located on both the high and low pressure side of the piping. The high side relief valve pressure setting is 650 PSIG. The low side relief valve pressure setting is 450 PSIG.

## HIGH PRESSURE CUTOUT

A high pressure cutout is installed in the discharge piping of each system. The cutout opens at 585 PSIG plus or minus 10 PSIG and closes at 440 PSIG plus or minus 25 PSIG.

## COMPRESSOR HEATERS

Compressor heaters are standard on all models. If power is OFF more than two hours, the crankcase heaters must be energized for 18 to 24 hours prior to restarting a compressor. This will assure that liquid slugging and oil dilution does not damage the compressors on start.

## REFRIGERANT PIPING

### General

When the unit has been located in its final position, the unit piping may be connected. Normal installation precautions should be observed in order to receive maximum operating efficiencies. System piping should conform to the YORK DX piping guide Form 050.40ES2 or ASHRAE refrigeration handbook guidelines. All piping design and installation is the responsibility of the user.

**QUANTECH ASSUMES NO WARRANTY RESPONSIBILITY FOR SYSTEM OPERATION OR FAILURES DUE TO IMPROPER PIPING, PIPING DESIGN, CONTROL PROBLEMS, OR LACK OF OIL RETURN.**

Filter driers and sight glasses are shipped loose for field installation on each refrigerant circuit. Field refrigerant piping can be connected to the condensing unit.

All expansion valves, liquid line solenoid valves, and refrigerant piping are field supplied and installed. TXV sizing should be equal in size or slightly smaller than the capacity of the circuit. If multiple coil sections are utilized, a TXV for each section (sized accordingly) must be installed.

## Refrigerant Piping Reference

### R-410A Copper Line Sizing

When selecting pipe diameter and material for piping R-410A systems such as used with QCC2 chillers, it is recommended that ASTM B280 material, type “L” or “K” is used. According to ASME Standard B31.5-2006 (table 502.3.1), ASTM B280 copper does not require a derate when brazed. By comparison, ASTM B88 material does take an annealing penalty when brazing, which in some applications, could reduce the calculated yield strength to a level below the system design.

### QCC2 Line Sizing Notes

The QCC2 chiller has a maximum design working pressure of 560 psig, a mechanical high pressure cut-out to shut the unit OFF at 585 psig, and (the unit) is rated at 650 psig. The maximum discharge pipe diameter used on QCC2 is 2-1/8”.

**TABLE 1 - FITTING EQUIVALENT LENGTHS**

*COPPER FITTING EQUIVALENT LENGTHS		
LINE SIZE O.D.	SHORT-RADIUS ELL	LONG-RADIUS ELL
3/4" (19mm)	6.5 ft. (2m)	4.5 ft. (1.4m)
7/8" (22mm)	7.8 ft. (2.4m)	5.3 ft. (1.6m)
1-1/8" (29mm)	2.7 ft. (.8m)	1.9 ft. (.6m)
1-3/8" (35mm)	3.2 ft. (1m)	2.2 ft. (.7m)
1-5/8" (41mm)	3.8 ft. (1.2m)	2.6 ft. (.8m)
2-1/8" (54mm)	5.2 ft. (1.6m)	3.4 ft. (1m)
2-5/8" (67mm)	6.5 ft. (20m)	4.2 ft. (1.3m)

ASTM B280, type “L” pipe, 2-1/8” diameter has a pressure rating of 608 psi per ASME B31.5-2006 section 504.1.2, with an additional 20% increase allowed in section 502.2.3 “Ratings: Allowance for Variations from Normal Operation” for a maximum allowable pressure of 730 psi.

Type “K” pipe (thicker wall), per ASME B31.5-2006 section 504.1.2, has a rating of 725 psi before the additional 20% allowance is taken.

*For more details, refer to “ASHRAE Refrigeration Handbook, Chapter 2” and YORK DX Piping Guide “Form 050.40-ES2”.*

Table 4 on page 34 lists refrigerant line connections sizes per unit model number.

**TABLE 2 - REFRIGERANT PIPING CHARGES**

R410A		SUCT @ 36 DEG		LIQ @ 105 DEG	
SUCTION LINES					
SIZE	ID	CU FT	DENSITY LB/CU FT	OZ/ FT	GRAMS/ 30 CM
1-3/8" (35mm)	1.3	0.0	2.1	0.3	8.1
1-5/8" (41mm)	1.5	0.0	2.1	0.4	11.5
2-1/8" (54mm)	2.0	0.0	2.1	0.7	20.0
2-5/8" (67mm)	2.5	0.0	2.1	1.1	30.9
LIQUID LINES					
3/4" (19mm)	0.7	0.0	60.9	2.4	66.8
7/8" (22mm)	0.8	0.0	60.9	3.3	92.8
1-1/8" (29mm)	1.0	0.0	60.9	5.6	158.3
1-3/8" (35mm)	1.3	0.0	60.9	8.5	241.1

**TABLE 3 - MISCELLANEOUS LIQUID LINE PRESSURE DROPS**

<b>*MISCELLANEOUS LIQUID LINE PRESSURE</b>	
<b>SOLENOID VALVE</b>	2 TO 3 PSI (13.8 TO 20.7 kPa)
<b>FILTER/DRIER</b>	2 TO 3 PSI (13.8 TO 20.7 kPa)
<b>SIGHT GLASS</b>	0.5 PSI (3.4 kPa)

\* Pressure drops or equivalent length values are approximate. If more precise value is desired, consult ASHRAE Refrigerant Handbook.

**TABLE 4 - REFRIGERANT LINE CONNECTIONS**

MODEL NUMBER	TONS	SYSTEM NUMBER	REFRIGERANT LINE CONNECTION		SUCTION LINE	LIQUID LINE	
			SUCTION	LIQUID	COPPER TYPE L INCHES OD	NOMINAL TONS UNLOADED	COPPER TYPE L INCHES OD
015CEE	17.0	1	1.6	0.9	1-5/8	8.5	7/8
020CEE	20.1	1	1.6	0.9	1-5/8	10.1	7/8
025CEE	27.0	1	2.1	1.1	2-1/8	12.3	1-1/8
030CEE	30.9	1	2.1	1.1	2-1/8	15.5	1-1/8
040CEE	41.6	1	2.1	1.1	2-1/8	10.4	1-1/8
		2	2.1	1.1	2-1/8	10.4	1-1/8
045CEE	44.1	1	2.1	1.1	2-1/8	11.7	1-1/8
		2	2.1	1.1	2-1/8	10.4	1-1/8
050CEE	51.6	1	2.1	1.1	2-1/8	12.9	1-1/8
		2	2.1	1.1	2-1/8	12.9	1-1/8
060CEE	59.5	1	2.1	1.1	2-1/8	14.9	1-1/8
		2	2.1	1.1	2-1/8	14.9	1-1/8
070CEE	73.5	1	2.1	1.1	2-3/8	21.9	1-1/8
		2	2.1	1.1	2-1/8	14.9	1-1/8

**REFRIGERANT PIPING NOTES**

1. Based on R-410A at the nominal capacity of the unit or system, an ambient temperature of 95°F (35°C) and a suction temperature of 45°F (7.2 °C).
2. Suction line sizes were calculated based on a nominal maximum pressure drop of 3 PSI/100 ft. (20.7kPa/30.5m).When calculating suction line pressure drop for a specific application, it should be noted that system capacity decreases as suction line pressure drop increases.
3. Liquid pressure drop (or gain) due to a vertical liquid line is not included in the tables and must be taken into account when determining pressure drop (or gain) of the liquid line. The nominal value that must be included in the liquid line loss (or gain) is .5 psi/foot (3.4 kPa/30 cm) of rise (or gain). To ensure a solid column of liquid refrigerant to the expansion valve, the total maximum pressure drop of the liquid line should not exceed 40 psi (276 kPa) based on 15°F (8.3 °C) subcooled liquid. Vapor in the liquid line, even in small amounts, will measurably reduce valve capacity and poor system performance will result. In addition, pressure loss for strainers, filter driers, solenoid valves, and isolation valve or fittings are not included in this table, and must be taken into account.
4. Nominal Tons (KW) Unloaded is based on one compressor (per system) operating at design conditions.
5. Based on minimum compressor staging for the given pipe size, a double suction riser should be used to ensure proper oil return to the compressor on all vertical suction risers. Oil returning up the riser moves up the inner surface of the pipe and depends on the mass velocity of the refrigerant vapor at the wall surface to move the oil up the vertical rise. Using piping of this size will allow velocities at part load to fall below 1000 fpm (5.08 m/s) minimum required for oil return.
6. Hot gas bypass lines are typically 7/8" for lines up to 40 feet and 1-1/8" for lines over 40 feet (12 meters) in length. The field connections sizes are 7/8" for the optional factory mounted hot gas bypass valve.
7. For more information, refer to either the YORK DX Piping Application Guide (Form 050.40-ES2) or the ASHRAE Refrigeration Handbook.

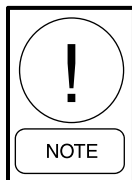

***Hot gas bypass is only available for refrigerant system number 1.***

## Refrigerant Line Sizing

Refrigerant piping systems must be designed to provide practical line sizes without excessive pressure drops, prevent compressor oil from being “trapped” in the refrigerant piping, and ensure proper flow of liquid refrigerant to the thermal expansion valve. Considerations should be given to:

1. Suction line pressure drop due to refrigerant flow.
2. Suction line refrigerant velocity for oil return.
3. Liquid line pressure drop due to refrigerant flow.
4. Liquid line pressure drop (or gain) due to vertical rise of the liquid line.

*Table 5 on page 39* provides the pressure drops for given pipe sizes for both liquid and suction lines. The pressure drops given are per 100 equivalent ft. (30.5 m) of refrigerant piping. These friction losses do not include any allowances for strainer, filter drier, solenoid valve, isolation valve, or fittings.

Nominal pressure drop for solenoids, sight glass, and driers are shown in Table 3.

*Table 1 on page 33* includes approximate equivalent lengths for copper fittings.

To ensure a solid column of liquid refrigerant to the expansion valve, the total liquid line pressure drop should never exceed 50 psi (3.4 bar). Refrigerant vapor in the liquid line will measurably reduce valve capacity and poor system performance can be expected.

To allow adequate oil return to the compressor, suction risers should be sized for a minimum of 1000 FPM (5.08 m/s) while the system is operating at minimum capacity to ensure oil return up the suction riser. Refer to Table 5 under column labeled “Nominal Tons (kW) Unloaded. For additional details, refer to “ASHRAE Refrigeration Handbook, Chapter 2”

## Evaporator Below Condensing Unit

On a system where the evaporator is located below the condensing unit, the suction line must be sized for both pressure drop and oil return. In some cases a double suction riser must be installed to ensure reliable oil return at reduced loads. Table 5 indicates when a double suction riser should be used for listed pipe sizes to provide adequate oil return at reduced loads. The calculated information was based on maintaining a minimum of 1000 fpm (5.08 m/s) refrigerant vapor velocity at full load.

## Condenser Below Evaporator

When the condensing unit is located below the evaporator, the liquid line must be designed for both friction loss and static head loss due the vertical rise. The value of static head loss of 0.5 psi/ft.(3.4 kPa/30 cm) must be added to the friction loss pressure drop in addition to all pressure drops due to driers, valves, etc.

## OIL TRAPS

All horizontal suction lines should be pitched at least 1/4" per foot (6 mm) in the direction of the refrigerant flow to aid in the return of oil to the compressor. All suction lines with a vertical rise exceeding 3 feet (.91 meters) should have a “P” trap at the bottom and top of the riser to facilitate oil return. Suction lines with a vertical rise exceeding 25 feet (7.6 meters) should be trapped every 15 feet (4.6 meters).

For more details, refer to “ASHRAE Refrigeration Handbook, System Practices for Halocarbon Refrigerants”.

On systems where oil return is a problem, oil separators may be required.

## REFRIGERANT CHARGE

The condensing unit is charged with a nitrogen holding charge. The remaining operating charge for the condensing unit, evaporator coil, and refrigerant piping must be “weighed-in” after all refrigerant piping is installed, leak checked, and evacuated.

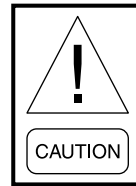

***70% of the calculated charge must be added prior to starting a system. Failure to add 70% of the charge may cause compressor overheating when the system is first started.***

Final adjustment of the refrigerant charge should be verified by subcooling values (*refer to “Pre-Startup” in Section 6 for checking subcooling*). See Table 2 on page 33 for Refrigerant Line Charges.

## REFRIGERANT PIPING REFERENCE

For more details, refer to ASHRAE Refrigeration Handbook, Chapter 2.

## FILTER DRIERS / SIGHT GLASSES/ TXV'S

Liquid line filter driers, sight glass, and TXV's are field supplied for each refrigerant circuit.

## SINGLE-POINT SUPPLY CONNECTION – TERMINAL BLOCK, NON-FUSED DISCONNECT SWITCH OR CIRCUIT BREAKER

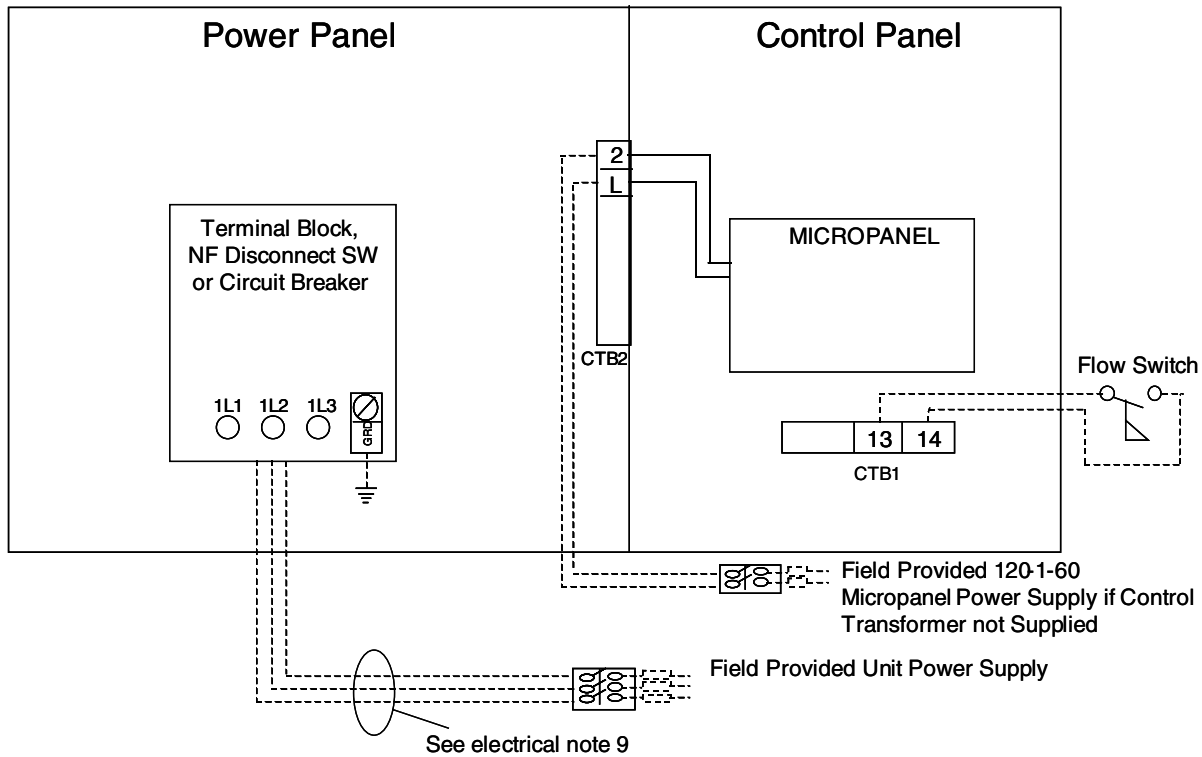

LD07719

Electrical Notes and Legend located on page 51.



*It is possible that multiple sources of power can be supplying the unit power panel. To prevent serious injury or death, the technician should verify that **NO LETHAL VOLTAGES** are present inside the panel **AFTER** disconnecting power, **PRIOR** to working on equipment.*

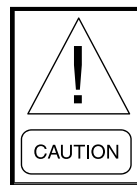

*The unit evaporator heater uses 120VAC. Disconnecting 120VAC power from the unit, at or below freezing temperatures, can result in damage to the evaporator and unit as a result of the chilled liquid freezing.*

**FIGURE 8 - SINGLE-POINT SUPPLY CONNECTION – TERMINAL BLOCK, NON-FUSED DISCONNECT SWITCH OR CIRCUIT BREAKER**

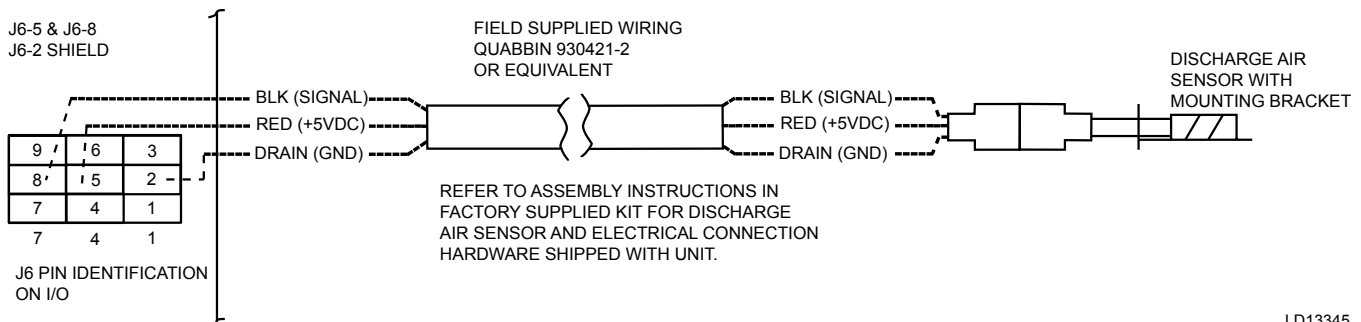

LD13345

**FIGURE 9 - DISCHARGE AIR SENSOR FIELD WIRING**



## CONTROL WIRING

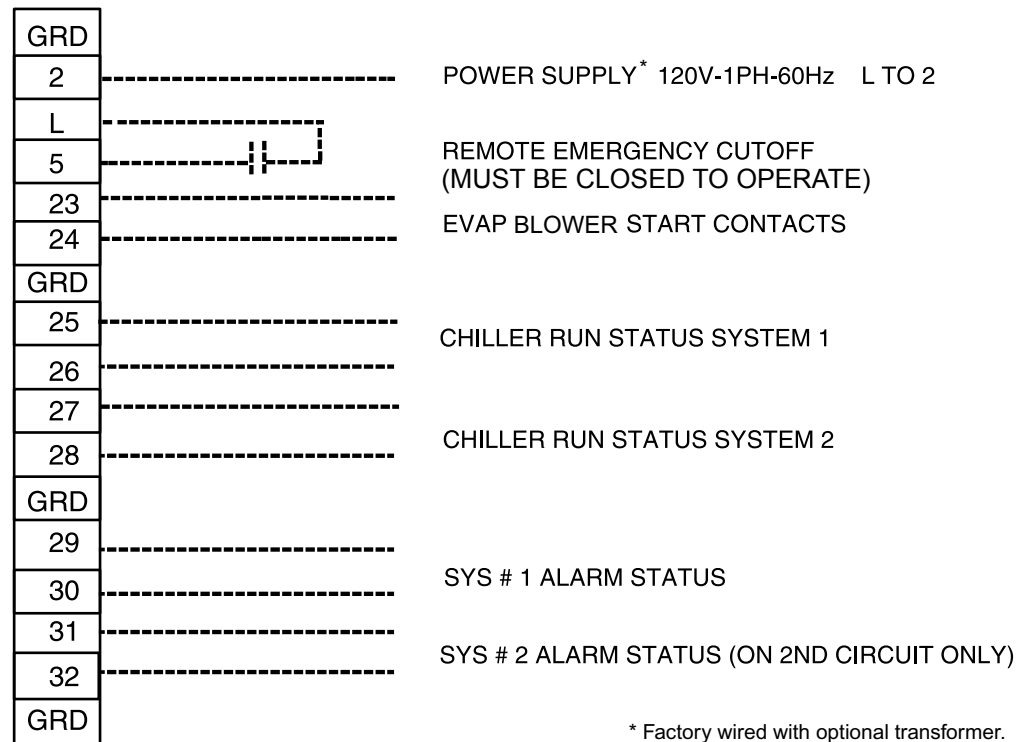
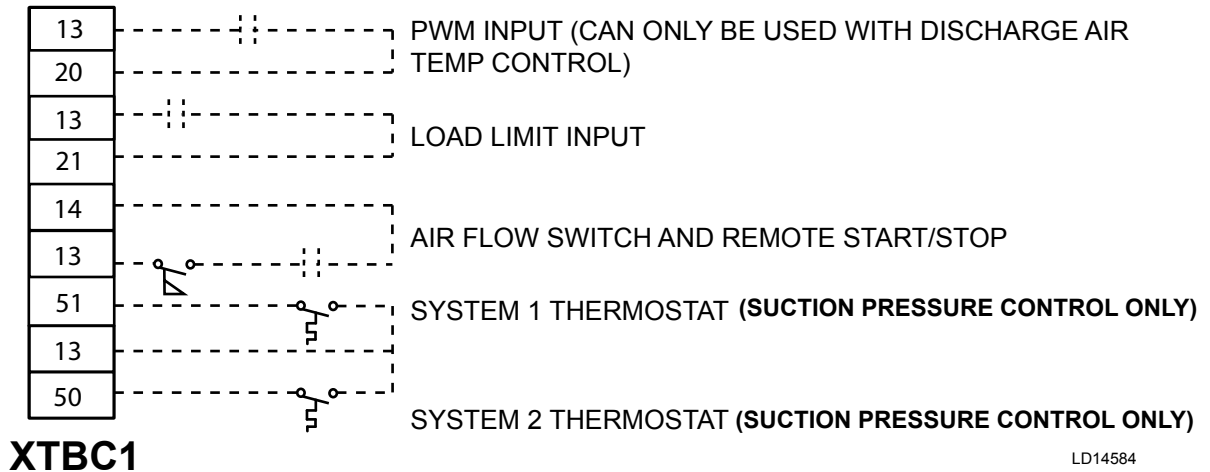

*It is possible that multiple sources of power can be supplying the unit power panel. To prevent serious injury or death, the technician should verify that **NO LETHAL VOLTAGES** are present inside the panel **AFTER** disconnecting power, **PRIOR** to working on equipment.*



*The unit evaporator heater uses 120VAC. Disconnecting 120VAC power from the unit, at or below freezing temperatures, can result in damage to the evaporator and unit as a result of the chilled liquid freezing.*

**FIGURE 10 - CONTROL WIRING**

THIS PAGE INTENTIONALLY LEFT BLANK

## SECTION 5 – TECHNICAL DATA

### OPERATIONAL LIMITATIONS (ENGLISH)



*Excessive flow will cause damage to the cooler. Do not exceed max. cooler flow. Special care should be taken when multiple chillers are fed by a single pump.*

#### NOTES:

1. For leaving brine temperature below 40°F (4.4°C), contact your nearest Quantech Sales Representative for application requirements.
2. For leaving water temperature higher than 55°F (12.8°C), contact the nearest Quantech Sales Representative for application guidelines.
3. The evaporator is protected against freezing to -20°F (-28.8°C) with an electric heater as standard.
3. For operation at temperatures below 25°F (-3.9°C), the optional Low Ambient Kit will need to be installed
4. For operation at temperatures above 115°F (46.1°C), the optional High Ambient Kit will need to be installed on the system.

#### Voltage Limitations

The following voltage limitations are absolute and operation beyond these limitations may cause serious damage to the compressor.

**TABLE 5 - VOLTAGE LIMITATIONS**

UNIT POWER	MIN.	MAX.
200-3-60	180	220
230-3-60	207	253
380/415-3-60	342	440
460-3-60	414	506
380/415-3-50	342	440
575-3-60	517	633

**PHYSICAL DATA (ENGLISH)****QCC2015C\_ – QCC2070C\_****60HZ****TABLE 6 - PHYSICAL DATA (ENGLISH)**

MODEL NO. QCC2		015CEE	020CEE	025CEE	030CEE	040CEE	045CEE	050CEE	060CEE	070CEE	
Length (inches)		109.8	109.8	118.6	118.6	144.8	144.8	148.8	148.8	153.6	
Width (inches)		44.7	44.7	44.7	44.7	90.6	90.6	90.6	90.6	90.6	
Height (inches)		46.1	46.1	50	50	47.8	47.8	62.6	62.6	62.6	
Nominal Tons		17	20.1	27	30.9	41.6	44.1	51.6	59.5	73.5	
Number of Refrigerant Circuits		1	1	1	1	2	2	2	2	2	
Refrig. Chg, Opt, R-410A (lbs) ckt1/ ckt2		17	25	40	45	35/35	40/35	45/45	50/50	65/65	
Oil Charge, gallons ckt1/ckt2		1.8	1.8	1.7	2.2	1.8/1.8	1.8/1.8	1.7/1.7	1.7/1.7	2.3/2.2	
Shipping Weight	Alum. Fin Coils, lbs	1454	1567	1798	2034	2942	2968	3196	3208	4097	
	Copper Fin Coils, lbs	1597	1781	2004	2240	3300	3326	3673	3685	4703	
Operating Weight	Alum. Fin Coils, lbs	1471	1592	1838	2079	2967	3001	3233	3245	4142	
	Copper Fin Coils, lbs	1614	1806	2044	2285	3325	3359	3710	3722	4748	
Nominal Comp. Capacity	Comp. 1	8	10	13	15	10	12	13	15	20	
	Comp. 2	8	10	13	15	10	12	13	15	20	
	Comp. 3	–	–	–	–	–	–	–	–	–	
	Comp. 4	–	–	–	–	10	10	13	15	15	
	Comp. 5	–	–	–	–	10	10	13	15	15	
	Comp. 6	–	–	–	–	–	–	–	–	–	
Condenser	Total Face Area ft2		35	35	44	44	87	87	116	116	128
	Number of Rows Deep	Ckt. 1	2	2	2	2	2	2	3	3	3
		Ckt. 2	–	–	–	–	2	2	3	3	3
Fins per Inch		17	17	13	13	17	17	17	17	13	
Condenser Fans, Low Sound	Number of fans	Ckt. 1	2	2	2	2	2	2	2	2	2
		Ckt. 2	–	–	–	–	2	2	2	2	2
	Fan Power hp/fan		2	2	2	2	2	2	2	2	2
	Fan RPM		1150	1150	1150	1150	1150	1150	1150	1150	1150
	Total Chiller CFM		10670	10670	24600	24600	39500	39500	43333	43333	43333
Condenser Fans, Ultra Quiet	Number of fans	Ckt. 1	NA	NA	NA	NA	2	2	2	2	2
		Ckt. 2	NA	NA	NA	NA	2	2	2	2	2
	Fan Power hp/fan		NA	NA	2	2	2	2	2	2	2
	Fan RPM		NA	NA	850	850	850	850	850	850	850
	Total Chiller CFM		NA	NA	24600	24600	39500	39500	43333	43333	43333

## ELECTRICAL DATA

**TABLE 7 - MICRO PANEL POWER SUPPLY**

UNIT VOLTAGE	UNIT VOLTAGE	CONTROL POWER	MCA NOTE A	OVER CURRENT PROTECTION, SEE NOTE B		NF DISC SW
MODELS w/o CONTROL TRANS		115-1-60/50		MIN	MAX	
			15A	10A	15A	30 A / 240V
MODELS w/ CONTROL TRANS	-17	200-1-60	15A	10A	15A	30 A / 240V
	-28	230-1-60	15A	10A	15A	30 A / 240V
	-40	380-1-60	15A	10A	15A	30 A / 480V
	-46	460-1-60	15A	10A	15A	30 A / 480V
	-50	380/415-1-60	15A	10A	15A	30A / 415V
	-58	575-1-60	15A	10A	15A	30 A / 600V

A. Minimum #14 AWG, 75 °C, Copper Recommended

B. Minimum and Maximum Over Current Protection, Dual Element Fuse or Circuit Breaker



*It is possible that multiple sources of power can be supplying the unit power panel. To prevent serious injury or death, the technician should verify that **NO LETHAL VOLTAGES** are present inside the panel **AFTER** disconnecting power, **PRIOR** to working on equipment.*



*The unit evaporator heater uses 120VAC. Disconnecting 120VAC power from the unit, at or below freezing temperatures, can result in damage to the evaporator and unit as a result of the chilled liquid freezing.*

5

**TABLE 8 - VOLTAGE RANGE**

VOLTAGE CODE	UNIT POWER	MIN.	MAX.
-17	200-3-60	180	220
-28	230-3-60	207	253
-40	380/415-3-60	342	440
-46	460-3-60	414	506
-50	380/415-3-50	342	440
-58	575-3-60	517	633

**Electrical Notes**

1. Minimum Circuit Ampacity (MCA) is based on 125% of the rated load amps for the largest motor plus 100% of the rated load amps for all other loads included in the circuit, per N.E.C. Article 430-24. If the optional Factory Mounted Control Transformer is provided, add the following MCA values to the electrical tables for the system providing power to the transformer: -17, add 2.5 amps; -28, add 2.3 amps; -40, add 1.5 amps, -46, add 1.3 amps; -58, add 1 amps.
2. The minimum recommended disconnect switch is based on 115% of the rated load amps for all loads included in the circuit, per N.E.C. Article 440.
3. Minimum fuse size is based upon 150% of the rated load amps for the largest motor plus 100% of the rated load amps for all other loads included in the circuit to avoid nuisance trips at start-up due to lock rotor amps. It is not recommended in applications where brown outs, frequent starting and stopping of the unit, and/or operation at ambient temperatures in excess of 95°F (35°C) is anticipated.
4. Maximum fuse size is based upon 225% of the rated load amps for the largest motor plus 100% of the rated load amps for all other loads included in the circuit, per N.E.C. Article 440-22.
5. Circuit breakers must be UL listed and CSA certified and maximum size is based on 225% of the rated load amps for the largest motor plus 100% of the rated load amps for all other loads included in the circuit. Otherwise, HACR-type circuit breakers must be used. Maximum HACR circuit breaker rating is based on 225% of the rated load amps for the largest motor plus 100% of the rated load amps for all other loads included in the circuit.
6. The “INCOMING WIRE RANGE” is the minimum and maximum wire size that can be accommodated by the unit wiring lugs. The (2) preceding the wire range indicates the number of termination points available per phase of the wire range specified. Actual wire size and number of wires per phase must be determined based on the National Electrical Code, using copper connectors only. Field wiring must also comply with local codes.
7. A ground lug is provided for each compressor system to accommodate a field grounding conductor per N.E.C. Table 250-95. A control circuit grounding lug is also supplied.
8. The supplied disconnect is a “Disconnecting Means” as defined in the N.E.C. 100, and is intended for isolating the unit for the available power supply to perform maintenance and troubleshooting. This disconnect is not intended to be a Load Break Device.
9. Field Wiring by others which complies to the National Electrical Code and Local Codes.

**LEGEND**

ACR-LINE	ACROSS THE LINE START	
C.B.	CIRCUIT BREAKER	
D.E.	DUAL ELEMENT FUSE	
DISC SW	DISCONNECT SWITCH	
FACT MOUNT CB	FACTORY MOUNTED CIRCUIT BREAKER	
FLA	FULL LOAD AMPS	
HZ	HERTZ	
MAX	MAXIMUM	
MCA	MINIMUM CIRCUIT AMPACITY	
MIN	MINIMUM	
MIN NF	MINIMUM NON FUSED	
RLA	RATED LOAD AMPS	
S.P. WIRE	SINGLE POINT WIRING	
UNIT MTD SERV SW	UNIT MOUNTED SERVICE (NON-FUSED DISCONNECT SWITCH)	
LRA	LOCKED ROTOR AMPS	

**VOLTAGE CODE**

-17	= 200-3-60
-28	= 230-3-60
-40	= 380-3-60
-46	= 460-3-60
-50	= 380/415-3-50
-58	= 575-3-60

## ELECTRICAL DATA

### QCC2015C - QCC2070C

MODEL QCC2	VOLT	HZ	MINIMUM CIRCUIT AMPS MCA	MIN N/F DISC SW MDSW	MIN DUAL ELEM FUSE	MAX DUAL ELEM FUSE MAX CB	SYSTEM # 1						SYSTEM # 2							
							COMPR 1		COMPR 2		FAN		COMPR 1		COMPR 2		FAN			
							RLA	LRA	RLA	LRA	QTY	FLA	LRA	RLA	LRA	RLA	LRA	QTY	FLA	LRA
015C	200	60	101	150	125	125	42.2	250	42.2	250	2	7.6	30.9							
	230	60	94	100	110	125	39	250	39	250	2	7.4	37							
	380	60	54	60	60	70	22.5	155	22.5	155	2	4.5	22.3							
	400	50	45	60	50	60	18.6	114	18.6	114	2	4	19							
	460	60	45	60	50	60	18.6	114	18.6	114	2	3.4	17.2							
	575	60	36	60	40	50	14.9	100	14.9	100	2	2.9	14.6							
	400	50	45	60	50	60	18.6	114	18.6	114	2	4	19							
020C	200	60	108	150	125	150	45.4	250	45.4	250	2	7.6	30.9							
	230	60	100	150	125	125	42	250	42	250	2	7.4	37							
	380	60	58	60	70	80	24.2	155	24.2	155	2	4.5	22.3							
	400	50	48	60	60	60	20	125	20	125	2	4	19							
	460	60	48	60	60	60	20	125	20	125	2	3.4	17.2							
	575	60	39	60	45	50	16	100	16	100	2	2.9	14.6							
	400	50	48	60	60	60	20	125	20	125	2	4	19							
025C	200	60	136	150	175	175	55.8	425	51.3	300	2	7.6	30.9							
	230	60	136	150	150	175	55.8	425	51.3	300	2	7.4	37							
	380	60	81	100	90	110	36	239	26.9	189	2	4.5	22.3							
	400	50	65	100	80	90	26.9	198	23.1	150	2	4	19							
	460	60	64	100	80	90	26.9	198	23.1	150	2	3.4	17.2							
	575	60	55	60	70	70	23.7	148	19.9	109	2	2.9	14.6							
	400	50	58	100	70	80	23.7	198	21.8	140	2	4	19							
030C	200	60	151	200	175	200	59.9	425	59.9	425	2	7.6	30.9							
	230	60	140	150	175	175	55.5	425	55.5	425	2	7.4	37							
	380	60	81	100	90	110	32	239	32	239	2	4.5	22.3							
	400	50	68	100	80	90	26.4	198	26.4	198	2	4	19							
	460	60	67	100	80	90	26.4	187	26.4	187	2	3.4	17.2							
	575	60	54	60	60	70	21.1	148	21.1	148	2	2.9	14.6							
	400	50	68	100	80	90	26.9	187	26.9	187	2	4	19							
040C	200	60	224	250	250	250	45.4	250	45.4	250	2	7.6	44	45.4	250	45.4	250	2	7.6	44
	230	60	209	250	225	250	42	250	42	250	2	7.4	37	42	250	42	250	2	7.4	37
	380	60	121	150	150	150	24.2	155	24.2	155	2	4.5	22.3	24.2	155	24.2	155	2	4.5	22.3
	400	50	102	150	110	110	20	125	20	125	2	4	19	20	125	20	125	2	4	19
	460	60	99	150	110	110	20	125	20	125	2	3.4	17.2	20	125	20	125	2	3.4	17.2
	575	60	80	100	90	90	16	100	16	100	2	2.9	14.6	16	100	16	100	2	2.9	14.6
	400	50	102	150	110	110	20	125	20	125	2	4	19	20	125	20	125	2	4	19
045C	200	60	228	250	250	250	47	250	47	250	2	7.6	44	45.4	250	45.4	250	2	7.6	44
	230	60	212	250	225	250	43.5	250	43.5	250	2	7.4	37	42	250	42	250	2	7.4	37
	380	60	123	150	150	150	25.1	155	25.1	155	2	4.5	22.3	24.2	155	24.2	155	2	4.5	22.3
	400	50	103	150	110	110	20.7	125	20.7	125	2	4	19	20	125	20	125	2	4	19
	460	60	101	150	110	110	20.7	125	20.7	125	2	3.4	17.2	20	125	20	125	2	3.4	17.2
	575	60	81	100	90	90	16.6	100	16.6	100	2	2.9	14.6	16	100	16	100	2	2.9	14.6
	400	50	103	150	110	110	20.7	125	20.7	125	2	4	19	20	125	20	125	2	4	19

5

See Electrical Notes on page 45.

## ELECTRICAL DATA

### QCC2015C - QCC2070C

MODEL QCC2	VOLT	HZ	MINIMUM CIRCUIT AMPS MCA	MIN N/F DISC SW MDSW	MIN DUAL ELEM FUSE	MAX DUAL ELEM FUSE MAX CB	SYSTEM # 1						SYSTEM # 2							
							COMPR 1		COMPR 2		FAN		COMPR 1		COMPR 2		FAN			
							RLA	LRA	RLA	LRA	QTY	FLA	LRA	RLA	LRA	RLA	LRA	QTY	FLA	LRA
050C	200	60	248	400	300	300	51.3	300	51.3	300	2	7.6	44	51.3	300	51.3	300	2	7.6	44
	230	60	248	400	300	300	51.3	300	51.3	300	2	7.4	19.1	51.3	300	51.3	300	2	7.4	19.1
	380	60	132	150	150	150	26.9	139	26.9	139	2	4.5	23.1	26.9	139	26.9	139	2	4.5	23.1
	460	60	114	150	125	125	23.1	150	23.1	150	2	4	19	23.1	150	23.1	150	2	4	19
	575	60	96	150	110	110	19.9	109	19.9	109	2	2.9	15.3	19.9	109	19.9	109	2	2.9	15.3
	400	50	106	150	125	125	21.8	140	21.8	140	2	3.4	17.5	21.8	140	21.8	140	2	3.4	17.5
060C	200	60	268	400	300	300	55.8	425	55.8	425	2	7.6	44	55.8	425	55.8	425	2	7.6	44
	230	60	267	400	300	300	55.8	425	55.8	425	2	7.4	19.1	55.8	425	55.8	425	2	7.4	19.1
	380	60	171	200	200	200	36	239	36	239	2	4.5	23.1	36	239	36	239	2	4.5	23.1
	460	60	130	150	150	150	26.9	187	26.9	187	2	4	19	26.9	187	26.9	187	2	4	19
	575	60	112	150	125	125	23.7	148	23.7	148	2	2.9	15.3	23.7	148	23.7	148	2	2.9	15.3
	400	50	114	150	125	125	23.7	198	23.7	198	2	3.4	17.5	23.7	198	23.7	198	2	3.4	17.5
070C	200	60	324	400	350	400	76.9	505	76.9	505	2	7.6	30.9	59.9	425	59.9	425	2	7.6	30.9
	230	60	301	400	350	350	71.2	505	71.2	505	2	7.4	37	55.5	425	55.5	425	2	7.4	37
	380	60	175	200	200	200	41.1	280	41.1	280	2	4.5	22.3	32	239	32	239	2	4.5	22.3
	400	50	146	200	175	175	33.9	225	33.9	225	2	4	19	26.4	198	26.4	198	2	4	19
	460	60	143	200	175	175	33.9	225	33.9	225	2	3.4	17.2	26.4	187	26.4	187	2	3.4	17.2
	575	60	115	150	125	125	27.1	180	27.1	180	2	2.9	14.6	21.1	148	21.1	148	2	2.9	14.6
	400	50	146	200	175	175	33.9	225	33.9	225	2	4	19	26.4	198	26.4	198	2	4	19



## ELECTRICAL NOTES AND LEGEND

DESIGNATION	DESCRIPTION
ACC	Accessory
- ADIS	Display Board
- AMB	Micro Board
- BAMB	Ambient
- BDAT	Discharge Air Temperature
- BDP	Discharge Pressure
- BECT	Entering Chilled Temperature
- BLCT	Leaving Chilled Temperature Not Fitted On Remote Evap Units
- BMP	Motor Protector Compressor
- BSP	Suction Pressure
- CPF	Capacitor Power Factor
- ECH	Crankcase Heater
- EEH	Evaporator Heater
- EHRH	Heat Recovery Heater
- EPH	Pump Heater
- EXT	External To Control Panel
- F	Fuse
- FHP	High Pressure Cutout
- FSC	Fan Speed Controller
- FSI	Fan Speed Inhibit Two Speed Fan Option Only
GND	Ground
G/Y	Green / Yellow
J	Plug Board Connector
- K	Circuit Board Relay
- KF	Fan Contactor Line (Including Coil Suppressor)
- KFH	Fan Contactor High Speed (Including Coil Suppressor)
- KFL	Fan Contactor Low Speed (Including Coil Suppressor)
- KFOL	Fan Overload
- KFS	Relay Fan Speed
- KH	Heater Relay
- KM	Compressor Contactor (Including Coil Suppressor)
- KCR	Control Relay
- KP	Pump Contactor Part (Including Coil Suppressor)
- KT	Relay Timer
- M	Compressor Motor
- MF	Motor Fan

DESIGNATION	DESCRIPTION
- MP	Motor Pump
NU	Not Used
PE	Protective Earth
PWM	Pulse Width Modulation Temp Reset Or Remote Unload 2Nd Step
- QCB	Circuit Breaker
- QMMS	Manual Motor Starter Compressor
- QMMS	Manual Motor Starter Pump
- QSD	Switch Disconnect
R	Resistor
RED	Red
RP	Run Permissive
RU	Remote Unload 1St Step
SCH	Thermostat Crankcase Heater
SCR	Screen
- SF	Flow Switch
- SKP	Keypad
- SOA	Switch Off Auto
- SZT	Zone Thermostat
- T	Transformer
- TC	Transformer Current
- UBR	Bridge Rectifier
- WHT	White
- XP	Plugs Between Pow./Microboard. Section
- XTBC	Terminal Block Customer
- XTBF	Terminal Block Factory
- YESV	Evaporator Solenoid Valve
- YHGSV	Hot Gas Solenoid Valve (Including Coil Suppressor)
- YLLSV	Liquid Line Solenoid Valve Field Mounted And Wired On Remote Evap. Units
- ZCPR	Compressor
Ⓝ	Note Well {See Note}
— · — · — · — · — · — ·	Wiring And Items Shown Thus Are Standard York Accessories
— · — · — · — · — · — ·	Wiring And Items Shown Thus Are Not Supplied By York
— — —	Items Thus Enclosed Form A Components Or Sets Of Components

5

035-21966-101 REVG

**ELECTRICAL NOTES AND LEGEND (CONTINUED)**

<b>GENERAL</b>	
a.	This drawing is based on IEC symbols.
b.	Field wiring to be in accordance with the relevant electrical code as well as all other applicable codes and specifications.
c.	All sources of supply shown on this diagram to be taken from one main isolator, not shown or supplied by Quantech.
d.	Green and yellow wire is used for earth, multi-colored cable used for low voltage. Red wire used for AC Control, blue wire for neutral, black wire for AC and DC power. Orange wire should be used for interlock control wiring supplied by external source.
e.	Legend designation depicts component abbreviations. Number prefix located, if applicable, on schematic circuit, refers to system thereon, E.G. = 1-FHP2 refers to high pressure cutout no 2 on system no 1.
f.	YLAA
g.	Customer voltage free contacts connected to terminal 13 must be rated at 30V 5ma.
h.	No controls {relays etc.} Should be mounted in any section of the control panel. Additionally, control wiring not connected to the YORK control panel should not be run through the panel. If these precautions are not followed, electrical noise could cause malfunctions or damage to the unit and its controls.
l	 120/14.3 -(Signal Input) i.e. 120 is wire # and 14.3 refers to sht. 14 column 3
<b>NOTES</b>	
1	Refer to installation commissioning operation and maintenance manual for customer connections and customer connection notes, non compliance to these instructions will invalidate unit warranty.
2	Wiring and components for compressor 3 only fitted when unit has 3 compressors on the system. 1-BMP3 is replaced by a link across terminals 134 and 135. 2-BMP3 is replaced by a link across terminals 234 and 235.
3	
4	Fitted on units with hot gas bypass option.
5	EMS option is wired as shown.
6	This wiring must be used for old display 031-0110-000.
7	Network connection point.
8	Printer port.
9	Remote emergency stop can be wired between terminal l and 5 after removing link.
10	Power factor correction accessory. Power factor correction fitted to each compressor contactor.
11	Not fitted on compressors with internal motor protection. For system 1 terminals 132 and 133, 133 and 134 and 134 and 135 are linked. For system 2 terminals 232 and 233, 233 and 234 and 234 and 235 are linked.
12	Only fitted on systems with 3 or 4 fans.
13	Only fitted on systems with 4 fans.
14	Only fitted on systems with 5 fans.
15	Only fitted on systems with 6 fans.
16	Input switch disconnect (standard on CE units) or circuit breaker option replaces input terminal block.
17	Input switch disconnect and individual system circuit breaker option replaces input terminal block.
18	115V control circuit requires a 115V supply unless control circuit transformer -T2 and -F3 are fitted (standard on CE units).
19	For optional hydro kit. Heater -EPH is fitted and wired as shown. On single pump -KP1, -QMMS1 and -MP1 are fitted and wired as shown. On two pump hydro kits -KP2, -QMMS2 and -MP2 are also fitted and wired as shown.
20	Current measurement option wired as show.
21	Only fitted on systems with single speed fans.
22	Only fitted on systems with two speed fans.
23	Optional compressor manual motors starters (standard on CE units).
24	See sheet 3 of connection diagram for power input options.
25	Alternate connections shown for different two speed motor types.

## ELECTRICAL NOTES AND LEGEND (CONTINUED)

26	Only fitted on systems with a maximum of 4 fans.
27	220/230V units require a separate fuse for units w/4 or more fans per system.
28	Low ambient kit -FSC for fan -MF1 is only fitted on systems with less than 4 fans.
29	
30	
31	Input dual point circuit breaker option replaces input terminal block.
32	Field installed on remote evaporator units.
33	Fitted on units with single phase motors only
34	Fitted on units with low ambient option only
35	Only fitted on units with an acoustic kit
36	Only fitted on heat recovery units
37	Only fitted on condensing units
38	Omitted on condensing units

035-21966-101 REVG



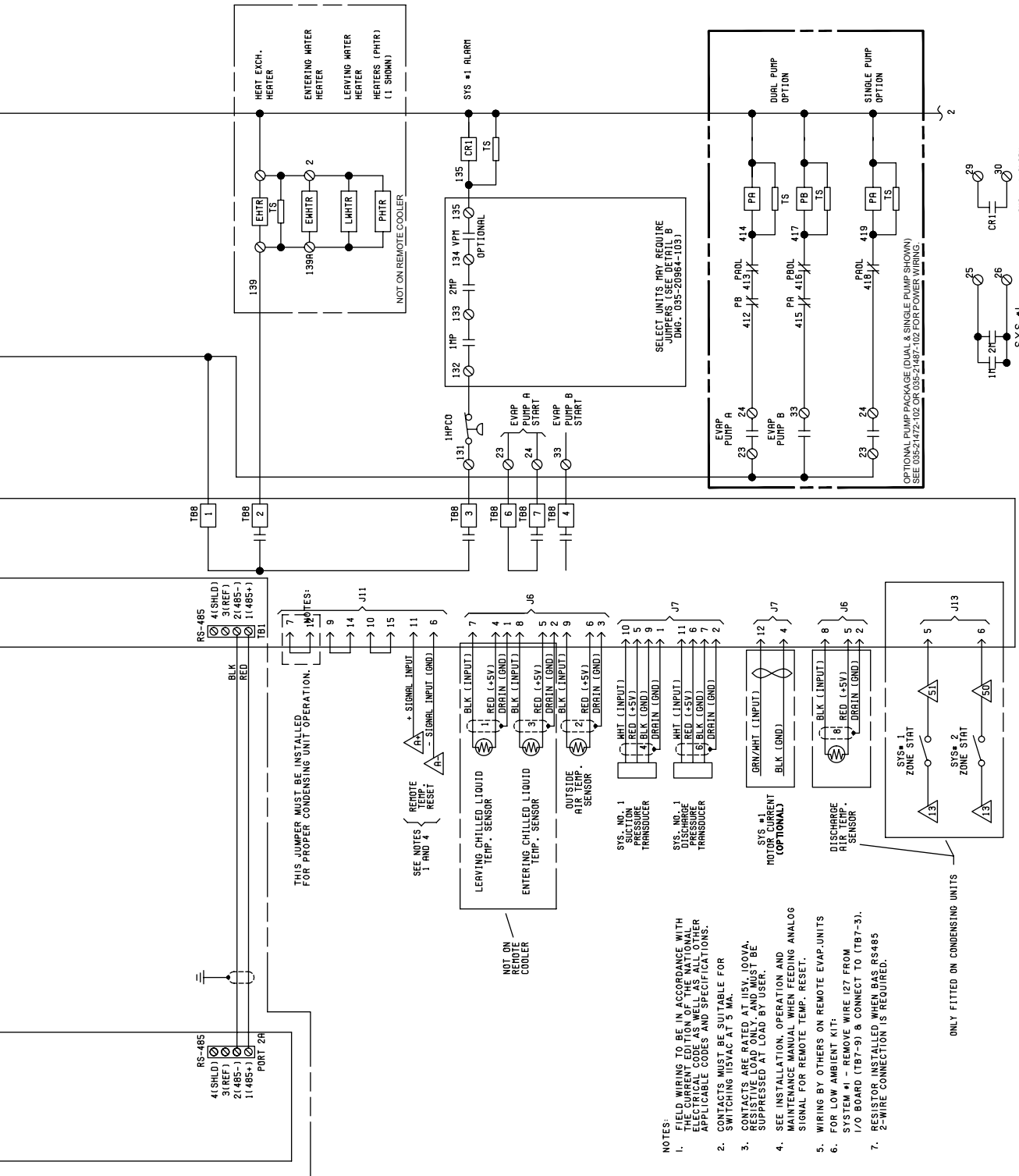
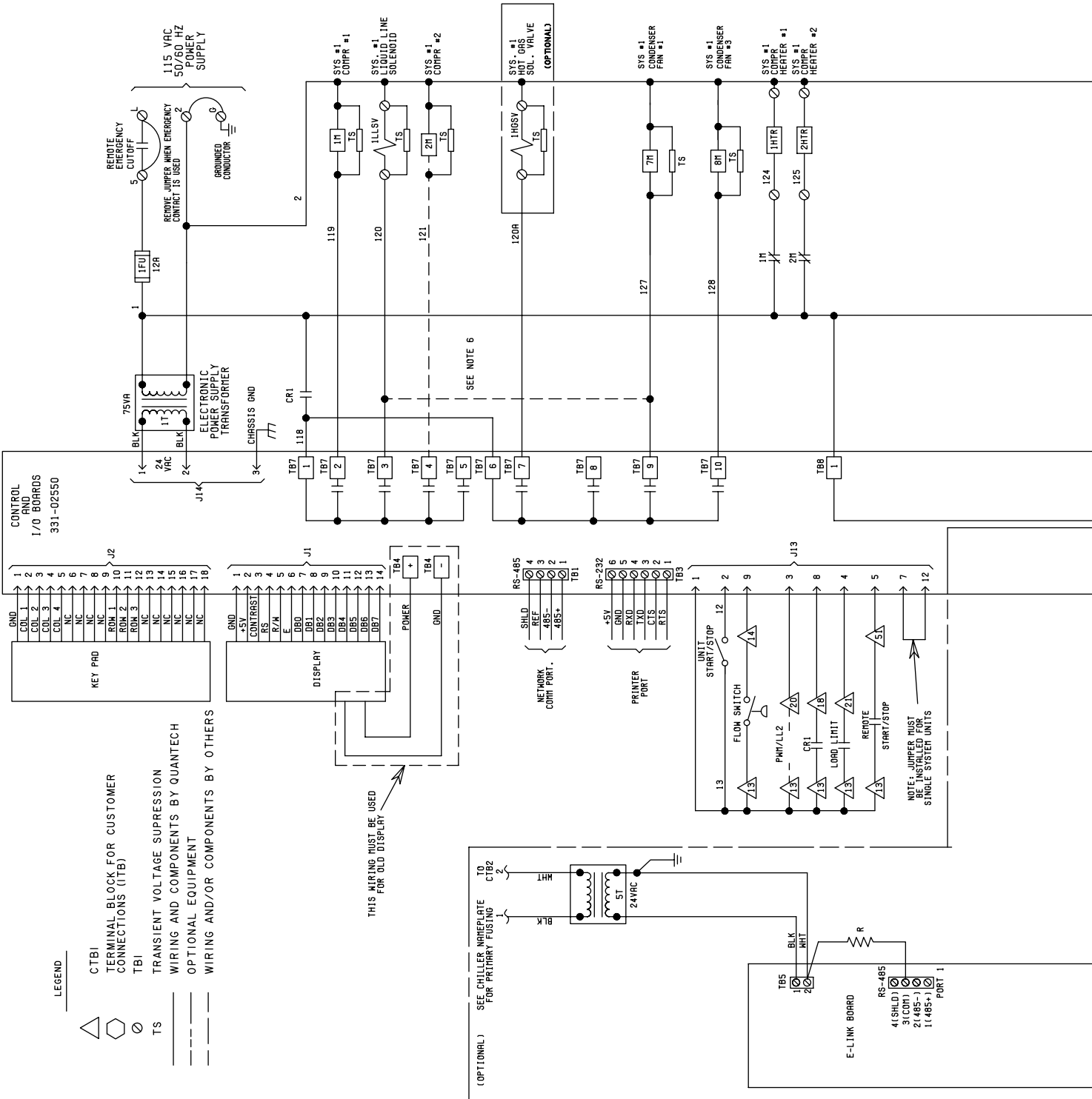

FIGURE 11 - CONTROL WIRING DIAGRAM, SINGLE CIRCUIT, IPU II (CONT'D)

# QCC2025C-030C ULTRA LOW SOUND (200V, 230V, 380V, AND 575V)

## ELEMENTARY DIAGRAM CONTROL CIRCUIT



LD22067a

FIGURE 12 - CONTROL WIRING DIAGRAM, SINGLE CIRCUIT, IPU II

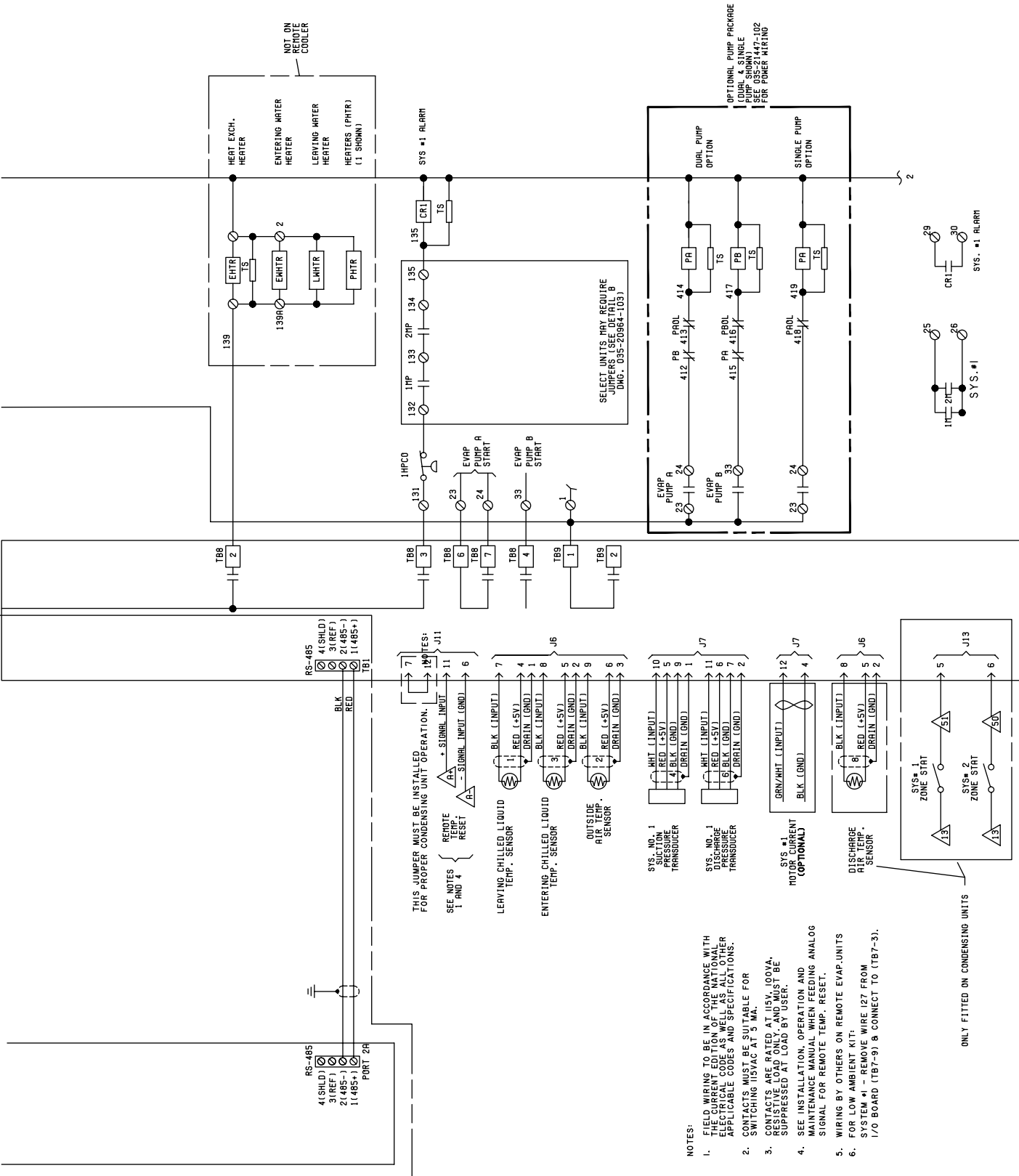
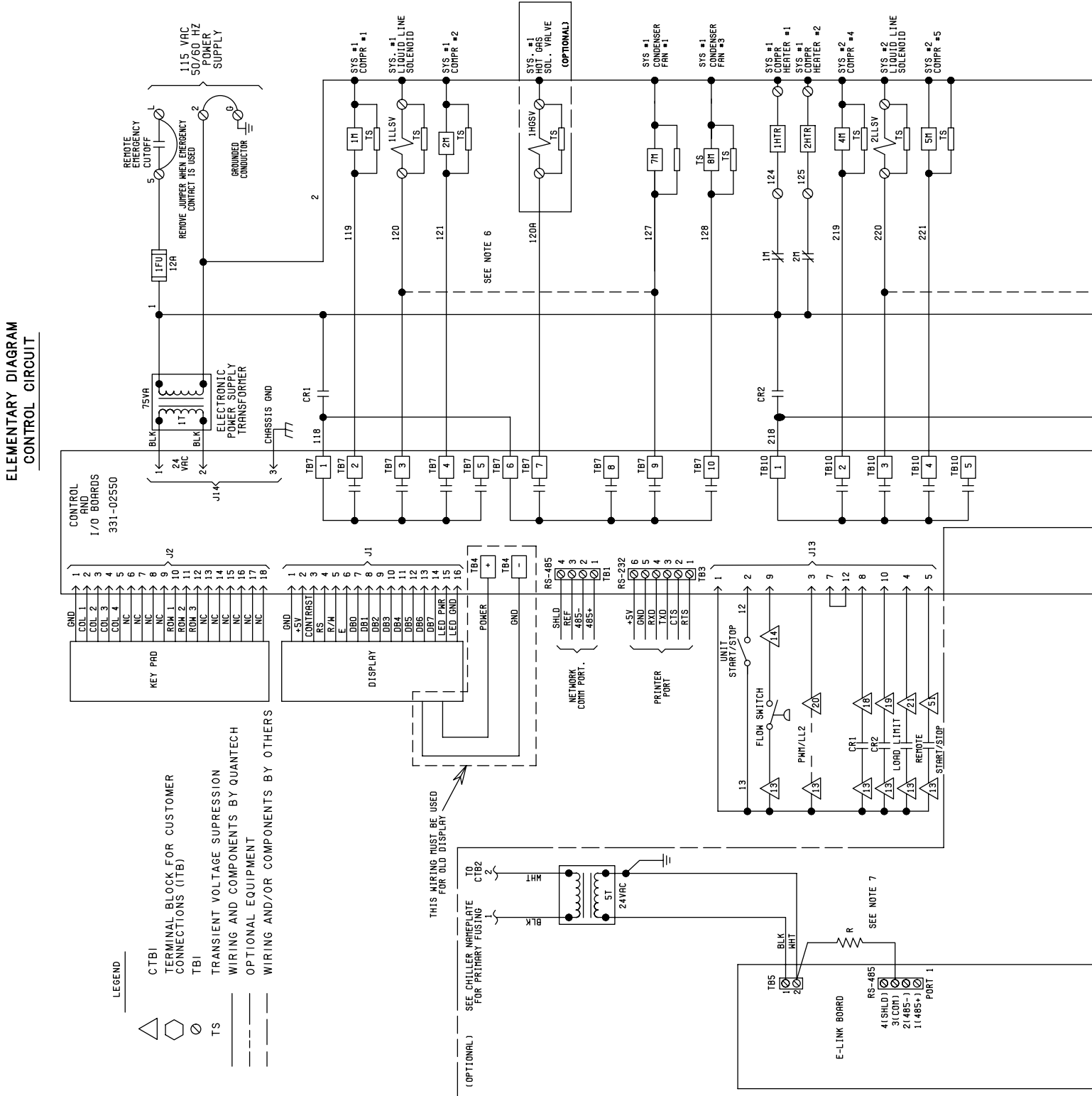

TABLE 12 - CONTROL WIRING DIAGRAM, SINGLE CIRCUIT, IPU II (CONT'D)

# QCC2040C-QCC2050C LOW SOUND QCC2040C-070C ULTRA LOW SOUND (460V AND 380-415V 50 HZ)



LD22068a

**FIGURE 13 - CONTROL WIRING DIAGRAM, DUAL CIRCUIT, IPU II**



035-21447-401 REV D

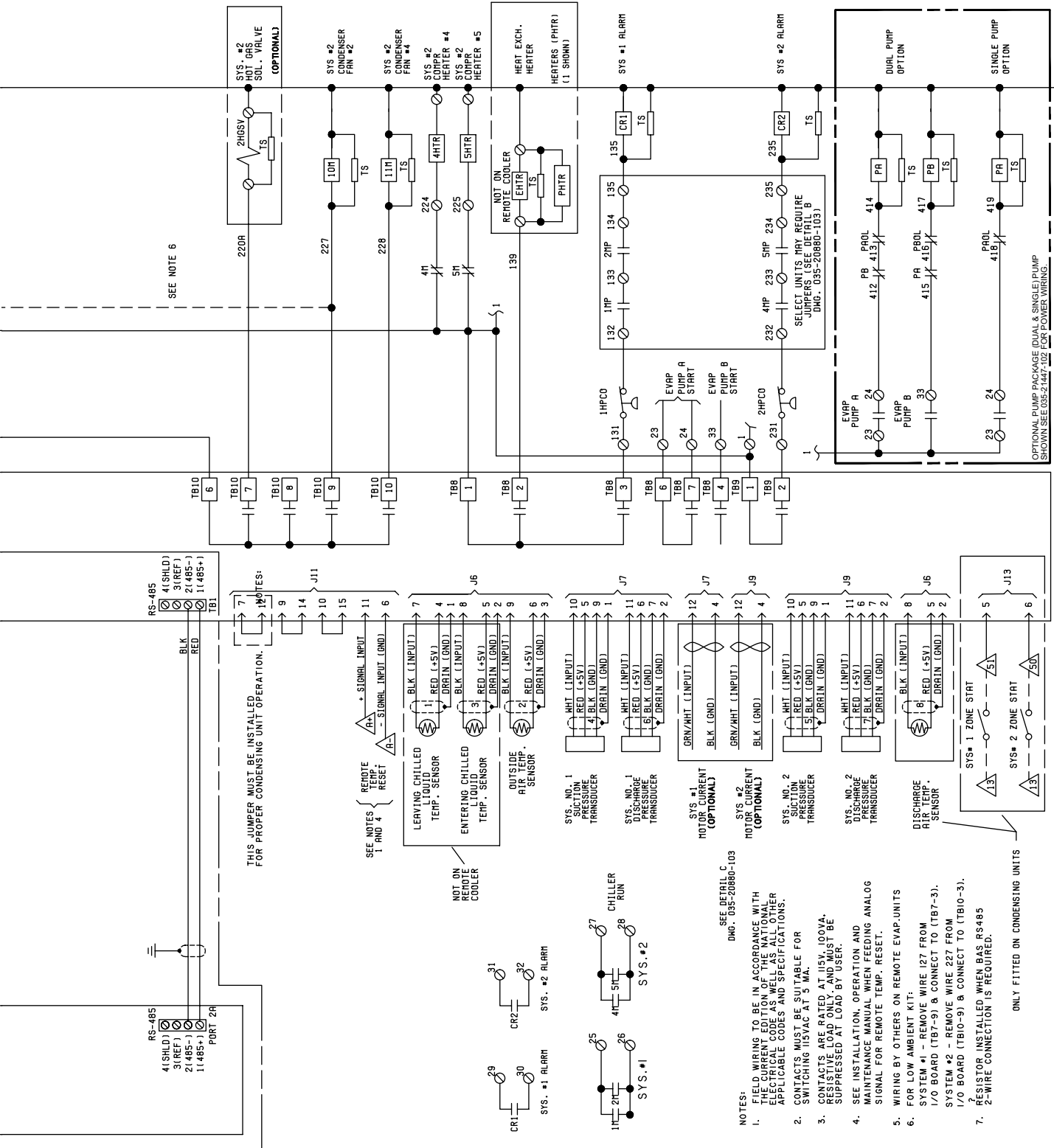

FIGURE 13 - CONTROL WIRING DIAGRAM, DUAL CIRCUIT, IPU II (CONT'D)





## QCC2015C-QCC2030C LOW SOUND QCC2025C-030C ULTRA LOW SOUND

035-20964-103 REV D

DETAIL "A"

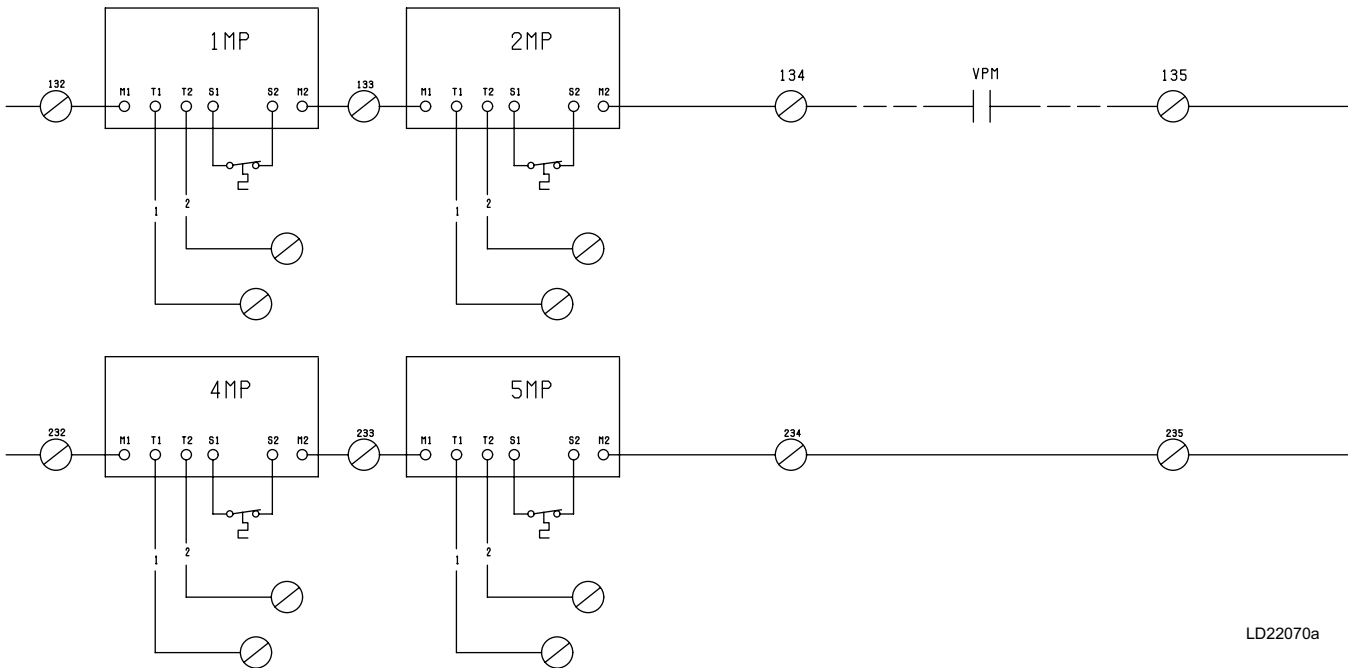

LD22070a





**NOTES:**

1. Field wiring to be in accordance with the current edition of the National Electrical Code as well as all other applicable codes and specifications.
2. Contacts must be suitable for switching 24VDC, (gold contacts recommended). Wiring shall not be run in the same conduit with any line voltage (class 1) wiring.
3. To cycle unit ON and OFF automatically with contact shown, install a cycling device in series with the flow switch. *See note 2 for contact rating and wiring specifications.*
4. To stop unit (emergency stop) with contacts other than those shown, install the stop contact between terminals 5 and 1. If a stop device is not installed, a jumper must be connected between terminals 5 and 1. Device must have a minimum contact rating of 6A at 115VAC.
5. Contacts are rated at 115V, 100VA, resistive load only, and must be suppressed at load by user.
6. *See installation, operation and maintenance manual when optional equipment is used.*
7. Optional current readout. 5V = 200A.
8. 1MP thru 3MP are contained in their respective compressor junction boxes.

**FIGURE 15 - CONTROL WIRING DIAGRAM, DETAILS, SINGLE CIRCUIT**

035-20964-103 REV D

LEGEND

- TS TRANSIENT VOLTAGE SUPPRESSION
-  TERMINAL BLOCK FOR CUSTOMER LOW VOLTAGE (CLASS 2) CONNECTIONS. SEE NOTE 2.
-  TERMINAL BLOCK FOR QUANTECH AND CUSTOMER CONNECTIONS
-  WIRING AND COMPONENTS BY QUANTECH
-  OPTIONAL EQUIPMENT
-  WIRING AND/OR COMPONENTS BY OTHERS

5

DETAIL "B"  
 TYPICAL FOR INTERNALLY PROTECTED MOTORS

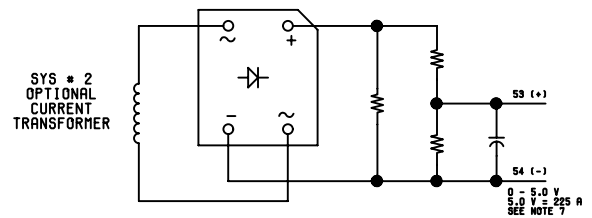
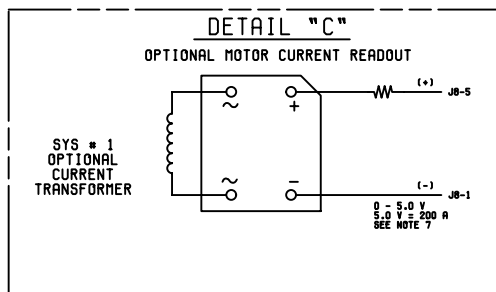
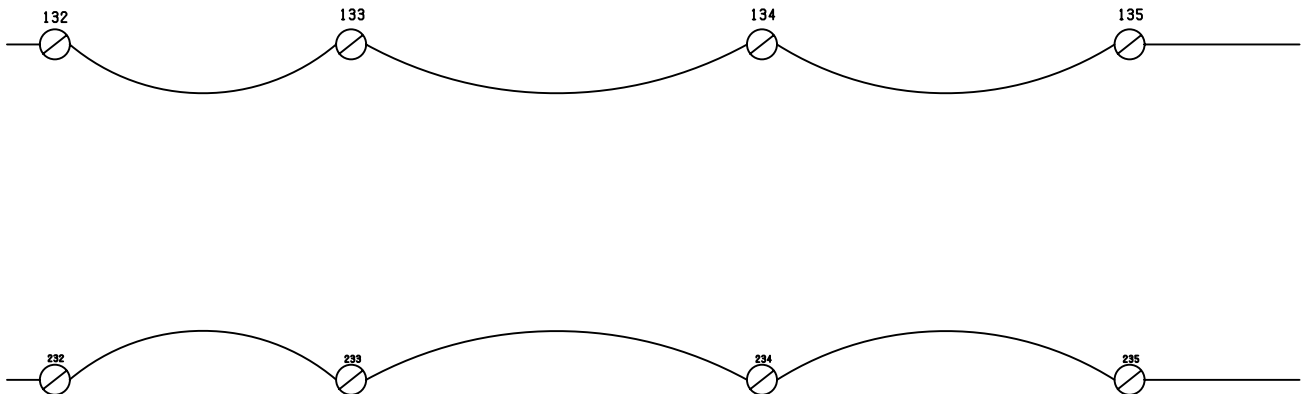

LD22070b

TABLE 15 - CONTROL WIRING DIAGRAM, DETAILS, SINGLE CIRCUIT (CONT'D)

## QCC2040C-QCC2070C LOW SOUND QCC2040C-070C ULTRA LOW SOUND

DETAIL "A"



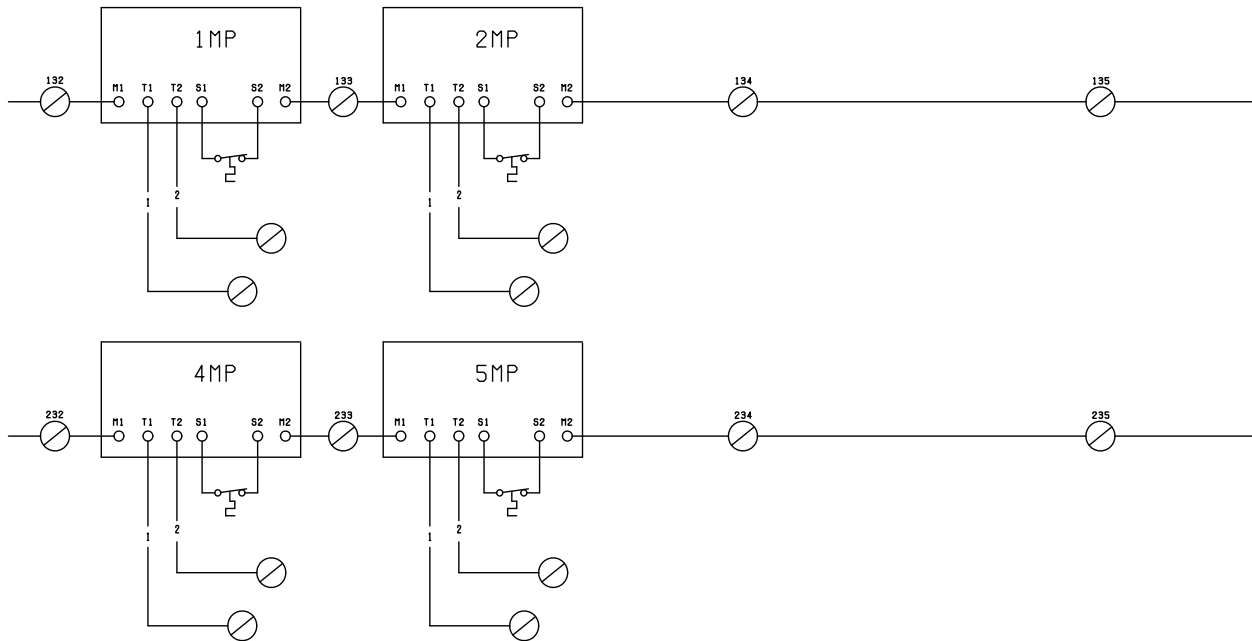

035-20880-103 REV C

**NOTES:**

1. Field wiring to be in accordance with the current edition of the National Electrical Code as well as all other applicable codes and specifications.
2. Contacts must be suitable for switching 24VDC, (gold contacts recommended). Wiring shall not be run in the same conduit with any line voltage (class 1) wiring.
3. To cycle unit on and off automatically with contact shown, install a cycling device in series with the flow switch. See note 2 for contact rating and wiring specifications.
4. To stop unit (emergency stop) with contacts other than those shown, install the stop contact between terminals 5 and 1. If a stop device is not installed, a jumper must be connected between terminals 5 and 1. Device must have a minimum contact rating of 6A at 115VAC.
5. Contacts are rated at 115V, 100VA, resistive load only, and must be suppressed at load by user.
6. See *installation, operation and maintenance manual when optional equipment is used*.
7. Optional current readout. 5V = 200A.
8. 1MP thru 6MP are contained in their respective compressor junction boxes.

**FIGURE 16 - CONTROL WIRING DIAGRAM, DETAILS, DUAL CIRCUIT**

LEGEND

- TS TRANSIENT VOLTAGE SUPPRESSION
-  TERMINAL BLOCK FOR CUSTOMER LOW VOLTAGE (CLASS 2) CONNECTIONS. SEE NOTE 2.
-  TERMINAL BLOCK FOR QUANTECH AND CUSTOMER CONNECTIONS
-  WIRING AND COMPONENTS BY QUANTECH
-  OPTIONAL EQUIPMENT
-  WIRING AND/OR COMPONENTS BY OTHERS

DETAIL "B"

TYPICAL FOR INTERNALLY PROTECTED MOTORS

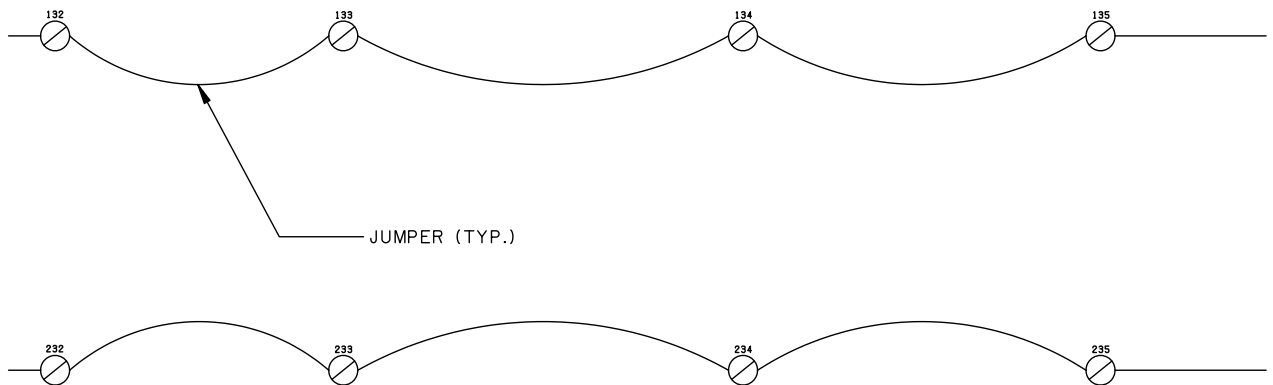

DETAIL "C"

OPTIONAL MOTOR CURRENT READOUT

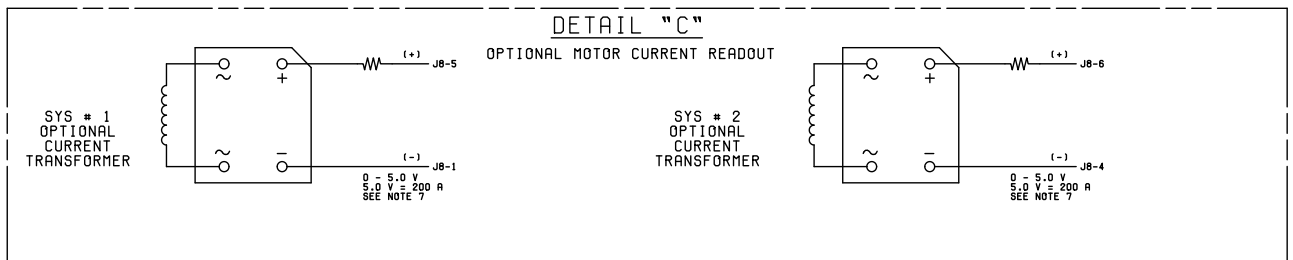
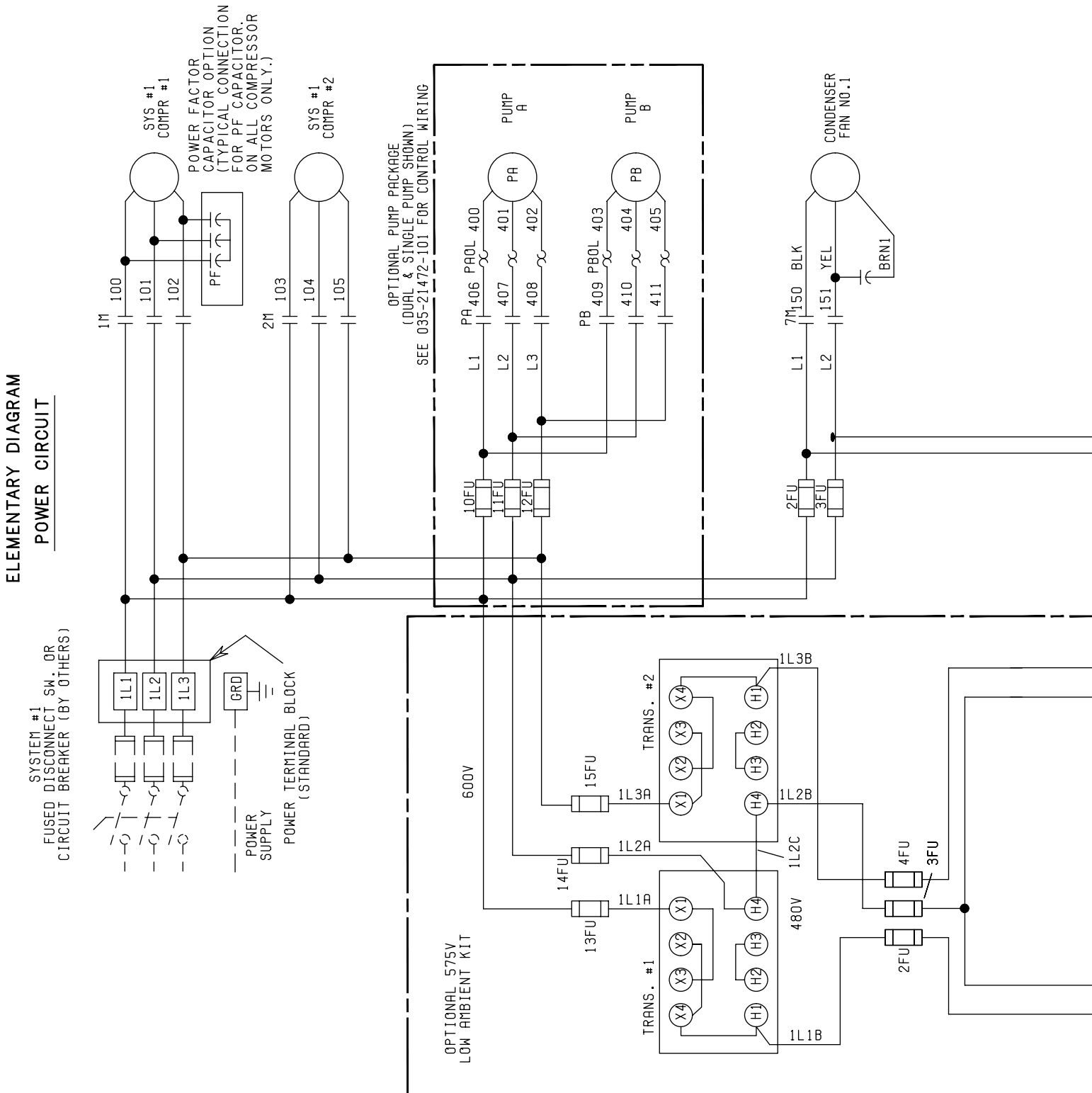

TABLE 16 - CONTROL WIRING DIAGRAM, DETAILS, DUAL CIRCUIT (CONT'D)

# POWER OPTIONS CONNECTION DIAGRAMS

## QCC2015C-QCC2020C LOW SOUND (200V, 230V, 380V, 460V AND 575V)



LD22102a

**FIGURE 17 - POWER WIRING, SINGLE CIRCUIT**



035-21487-102 REV B

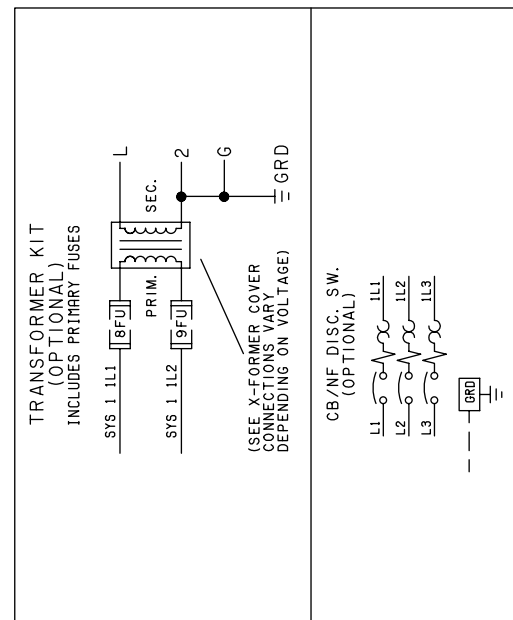
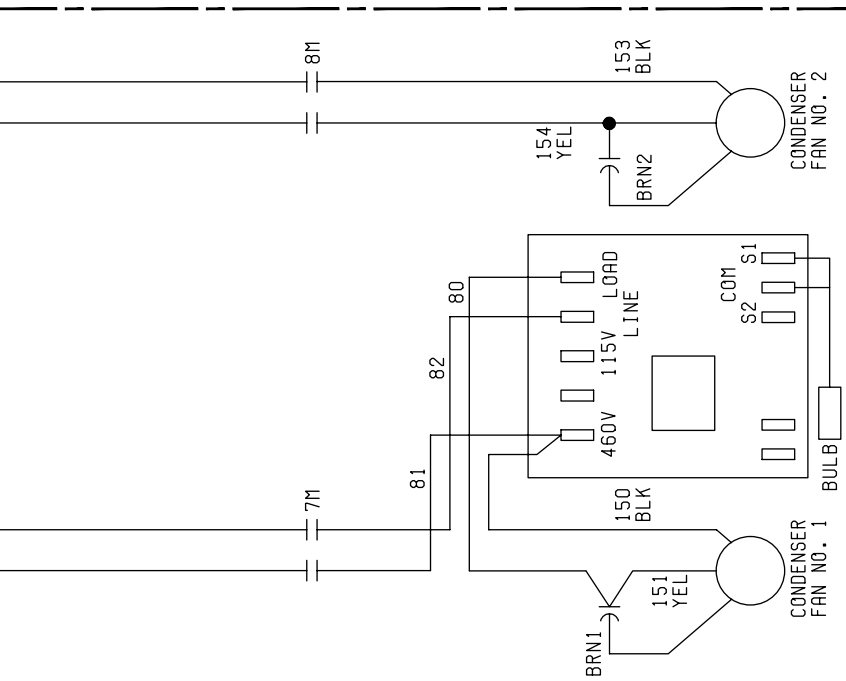
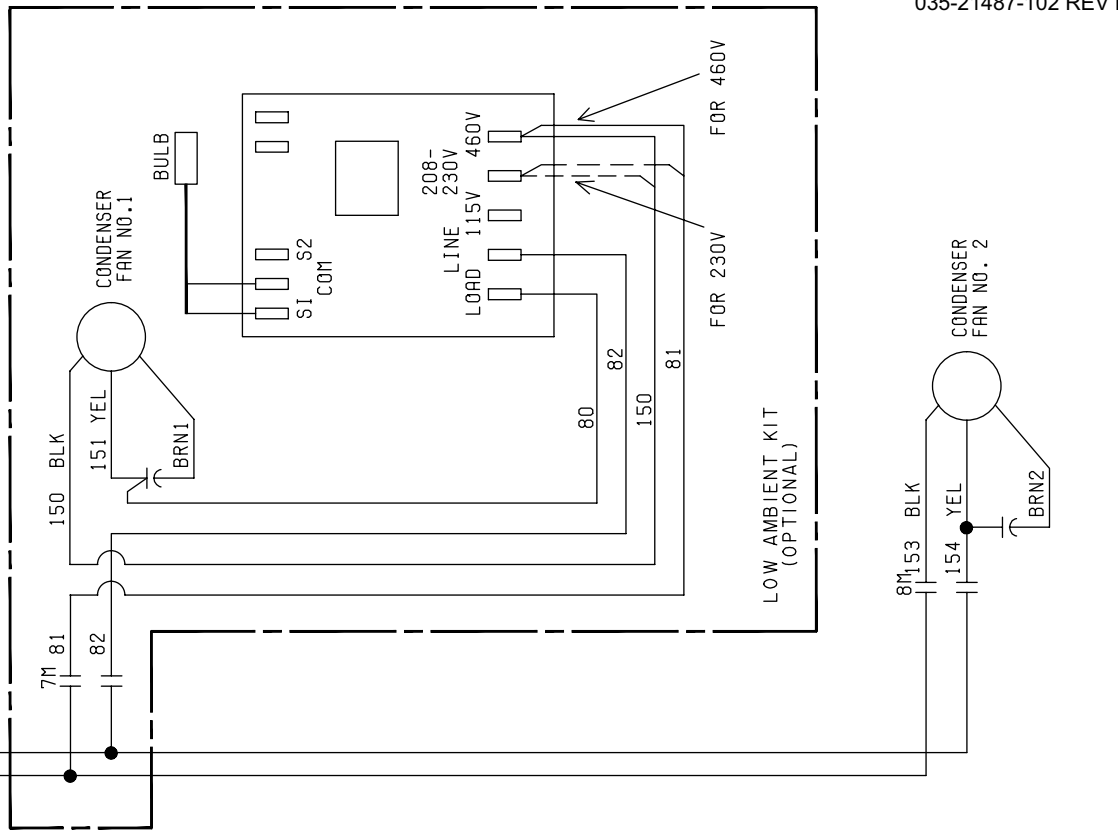

LD22102b

TABLE 17 - POWER WIRING, SINGLE CIRCUIT (CONT'D)

# POWER OPTIONS CONNECTION DIAGRAMS

## QCC2015C-QCC2020C LOW SOUND (380-415V/3/50)

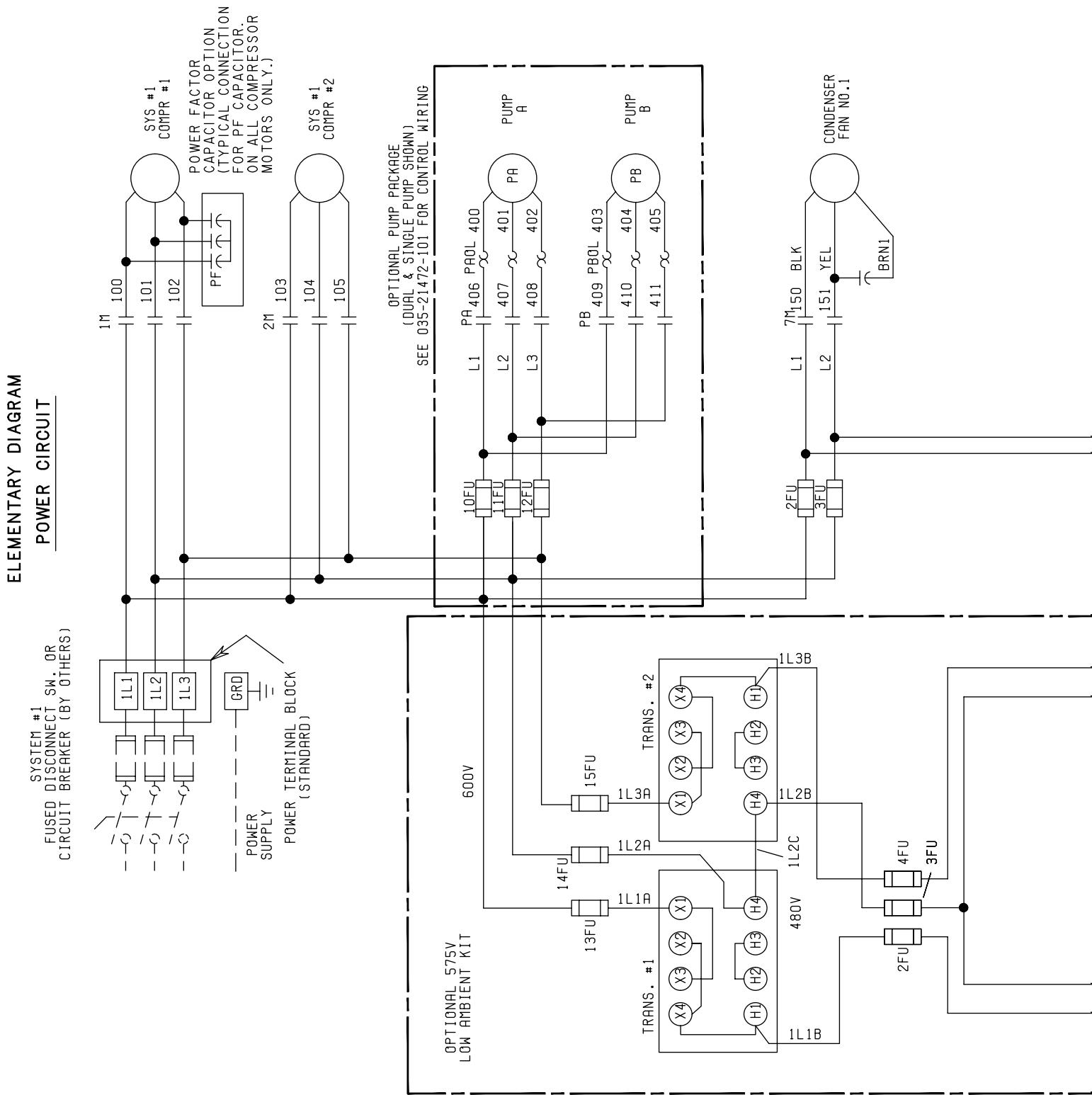

LD22103a

FIGURE 18 - POWER WIRING, SINGLE CIRCUIT

035-21487-105 REV B

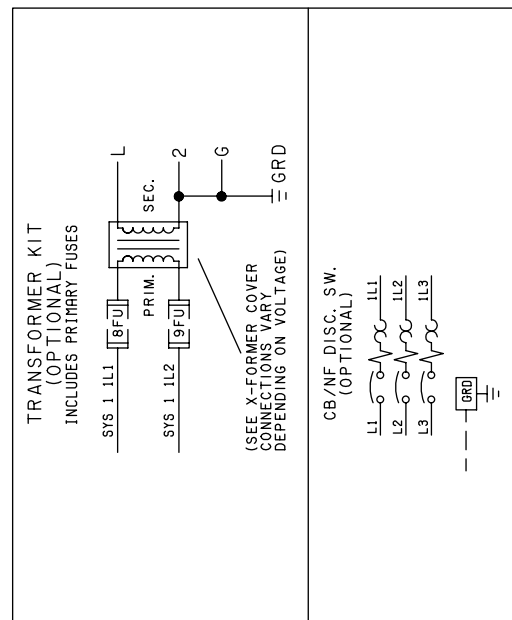
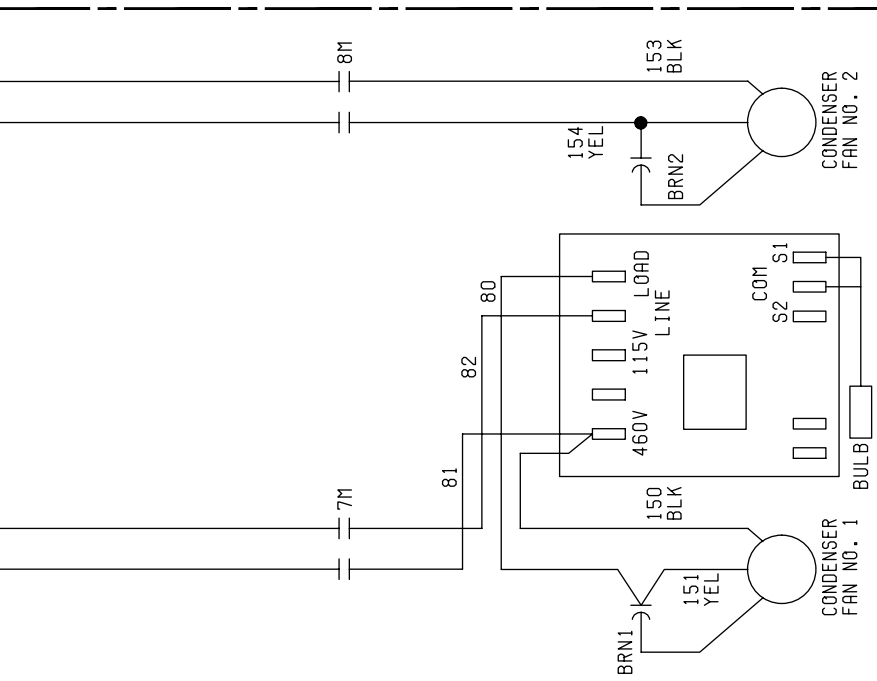
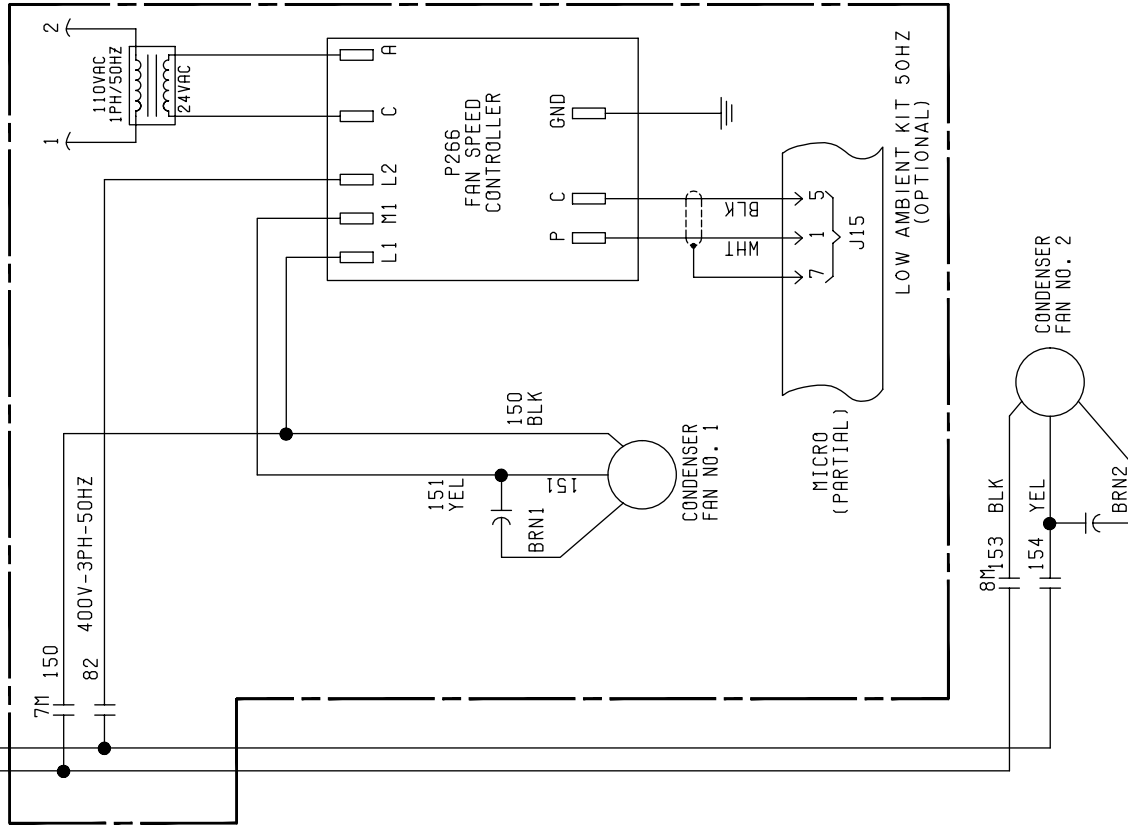

LD22103b

FIGURE 18 - POWER WIRING, SINGLE CIRCUIT (CONT'D)

## QCC2025C-QCC2030C LOW SOUND QCC2025C-QCC2030C ULTRA LOW SOUND (460V AND 380-415V/3/50)

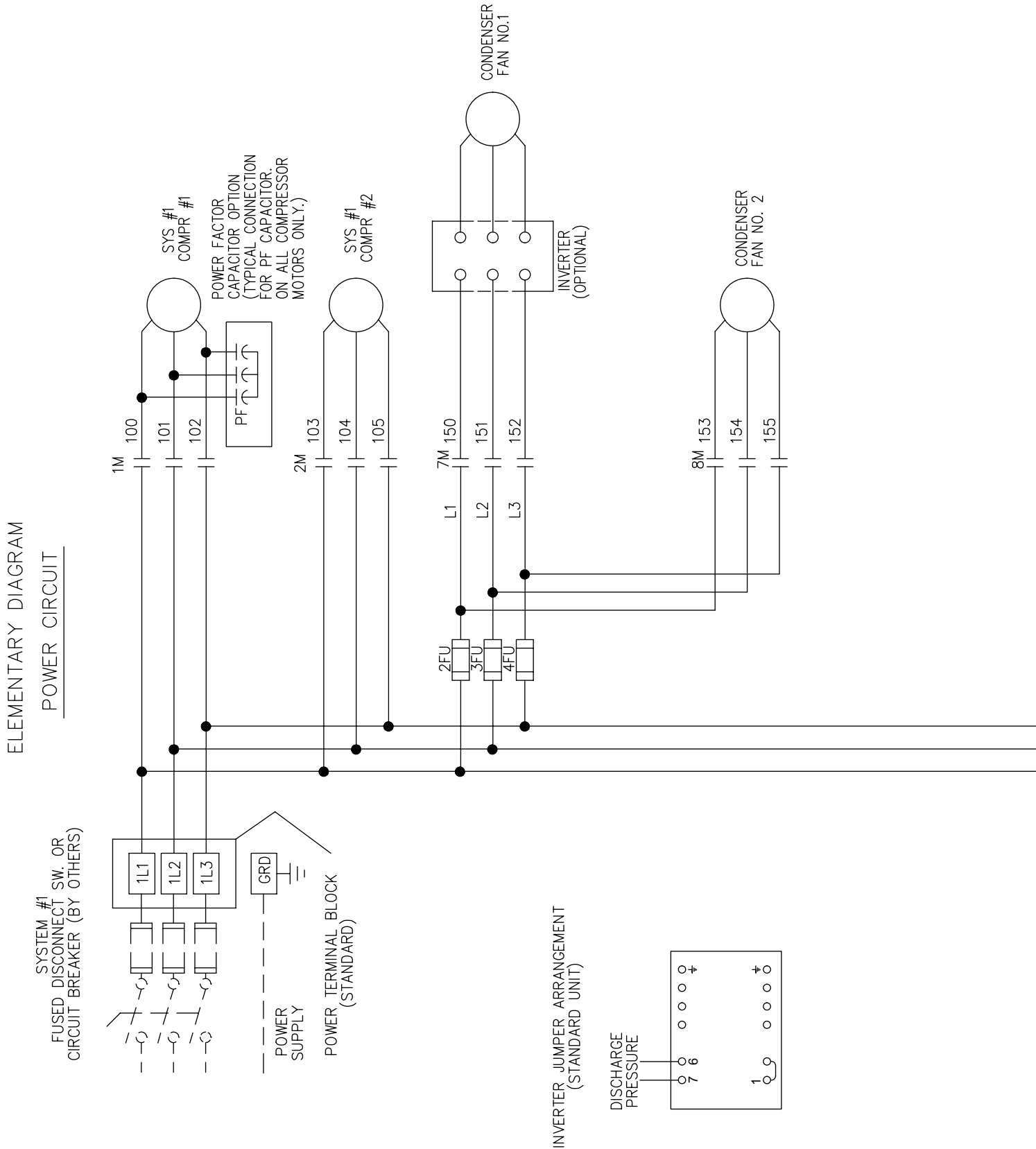

**FIGURE 19 - POWER WIRING, SINGLE CIRCUIT**

LD22104a

035-21472-102 REV D

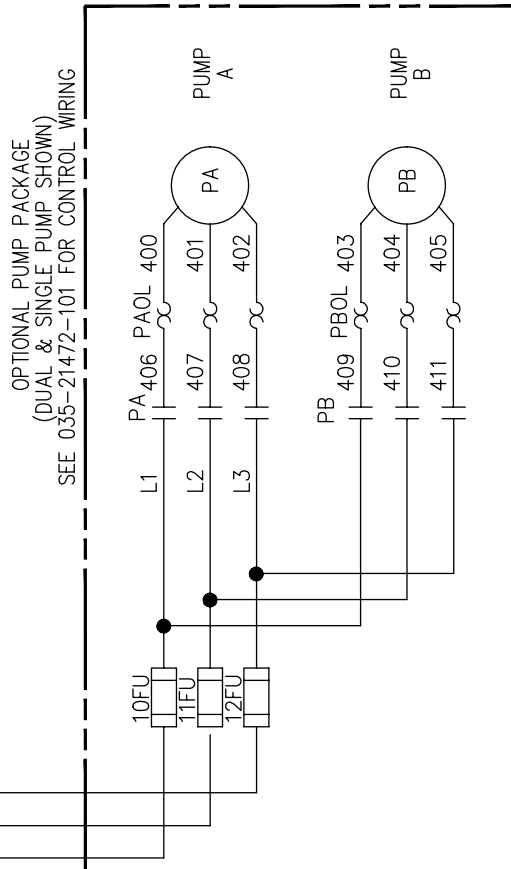

INVERTER JUMPER ARRANGEMENT  
 (575 V. ONLY)

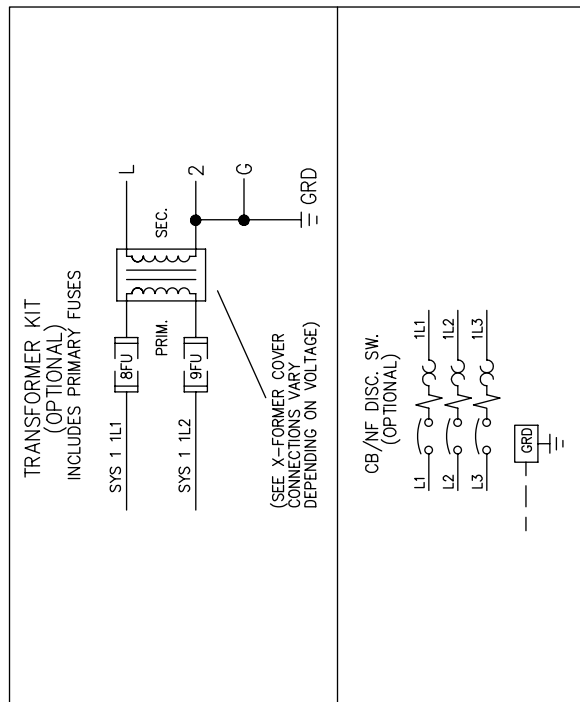
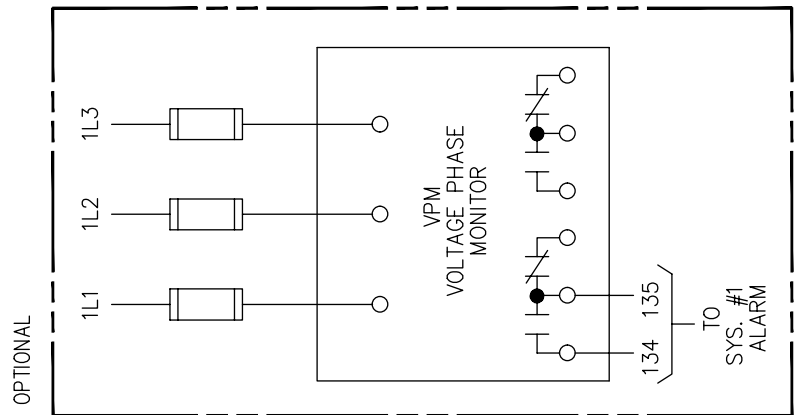
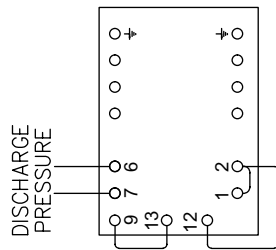

FIGURE 19 - POWER WIRING, SINGLE CIRCUIT (CONT'D)

LD22104b

# QCC2025C-QCC2030C ULTRA LOW SOUND (200V, 230V, 380V AND 575V)

ELEMENTARY DIAGRAM

POWER CIRCUIT

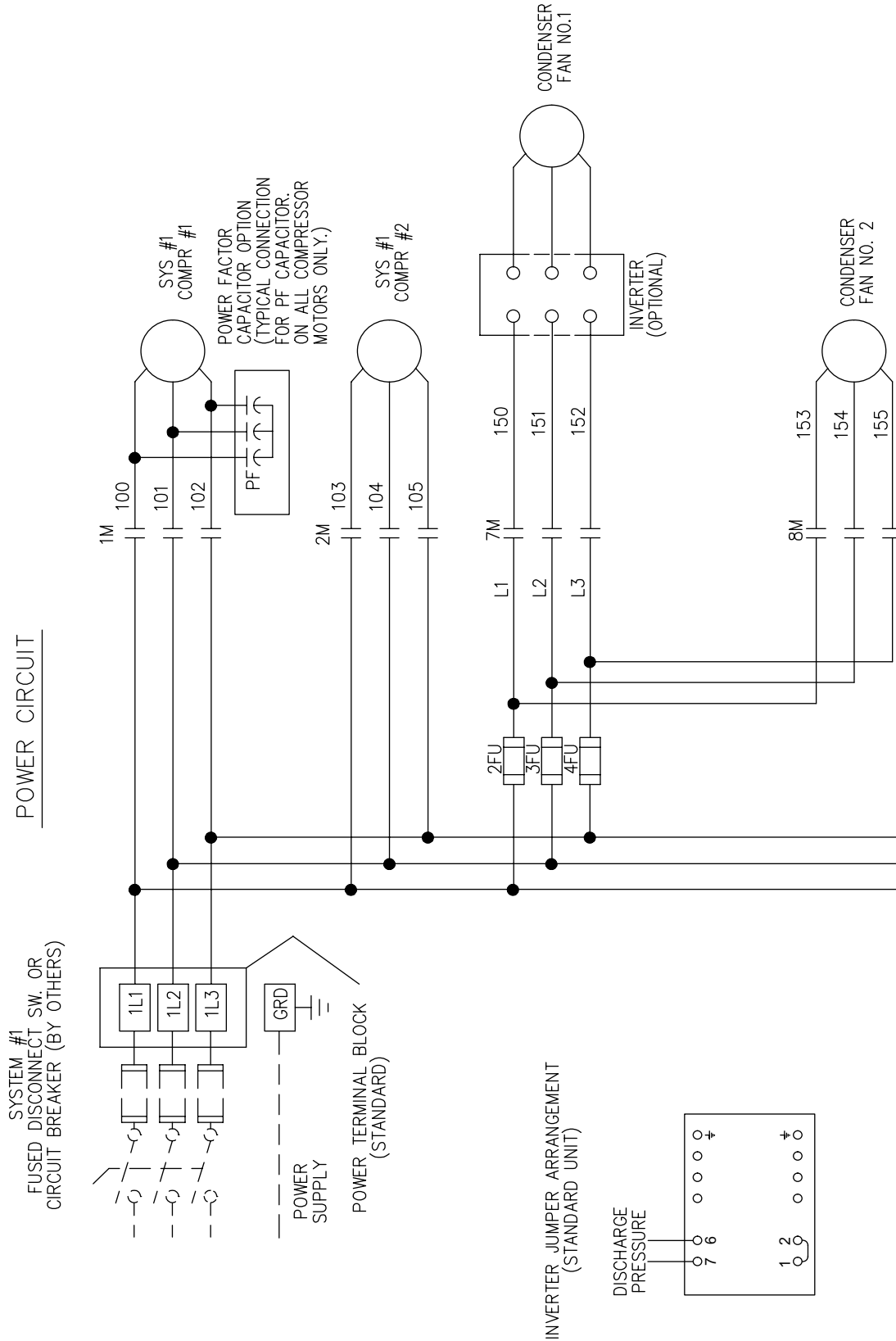

FIGURE 20 - POWER WIRING, SINGLE CIRCUIT

LD22105a



## QCC2040C-QCC2050C LOW SOUND QCC2040C-070C ULTRA LOW SOUND (460V AND 380-415V 50 HZ)

ELEMENTARY DIAGRAM

POWER CIRCUIT

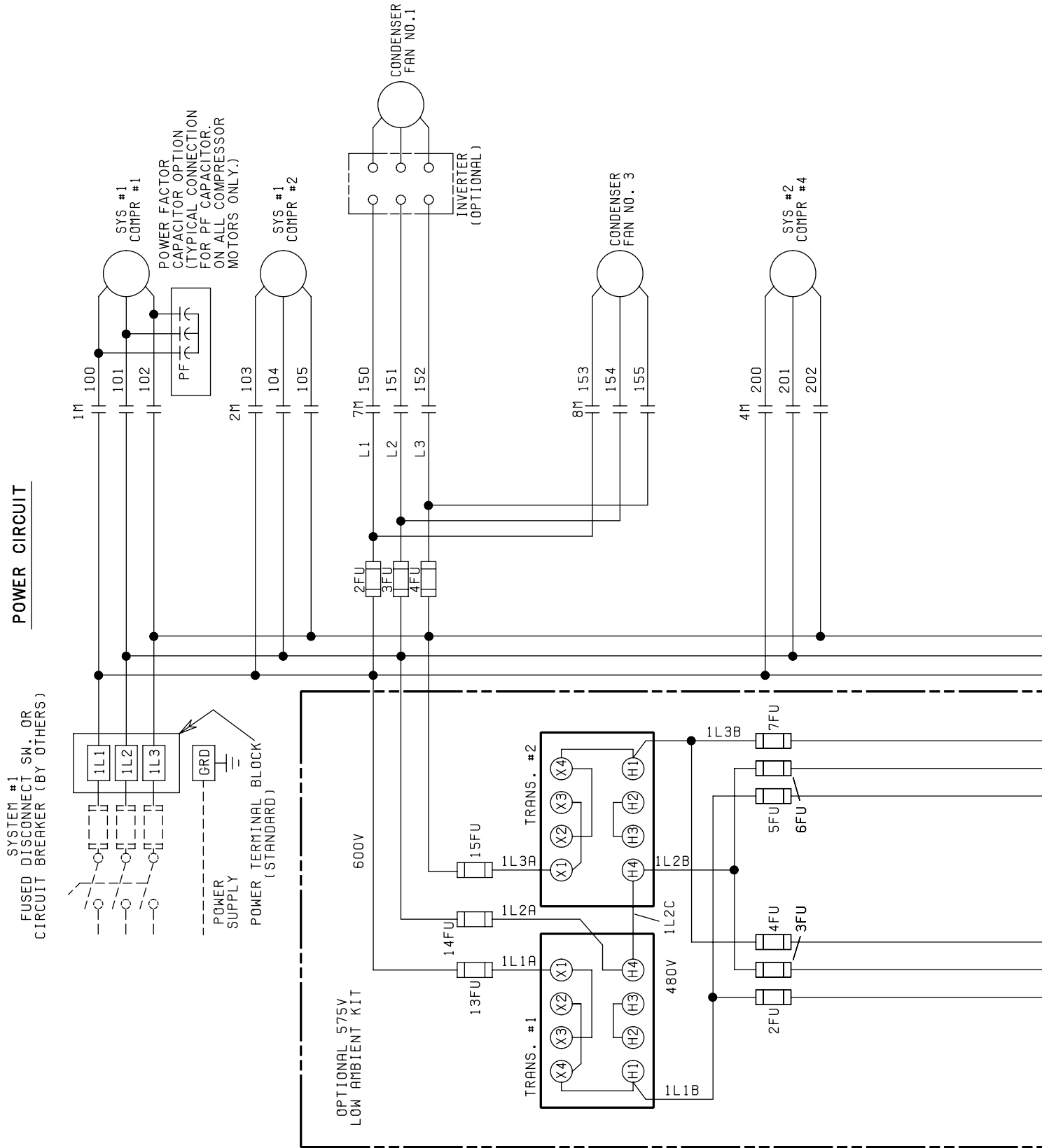

LD22106a

**FIGURE 21 - POWER WIRING, DUAL CIRCUIT**



035-21447-102 REV A

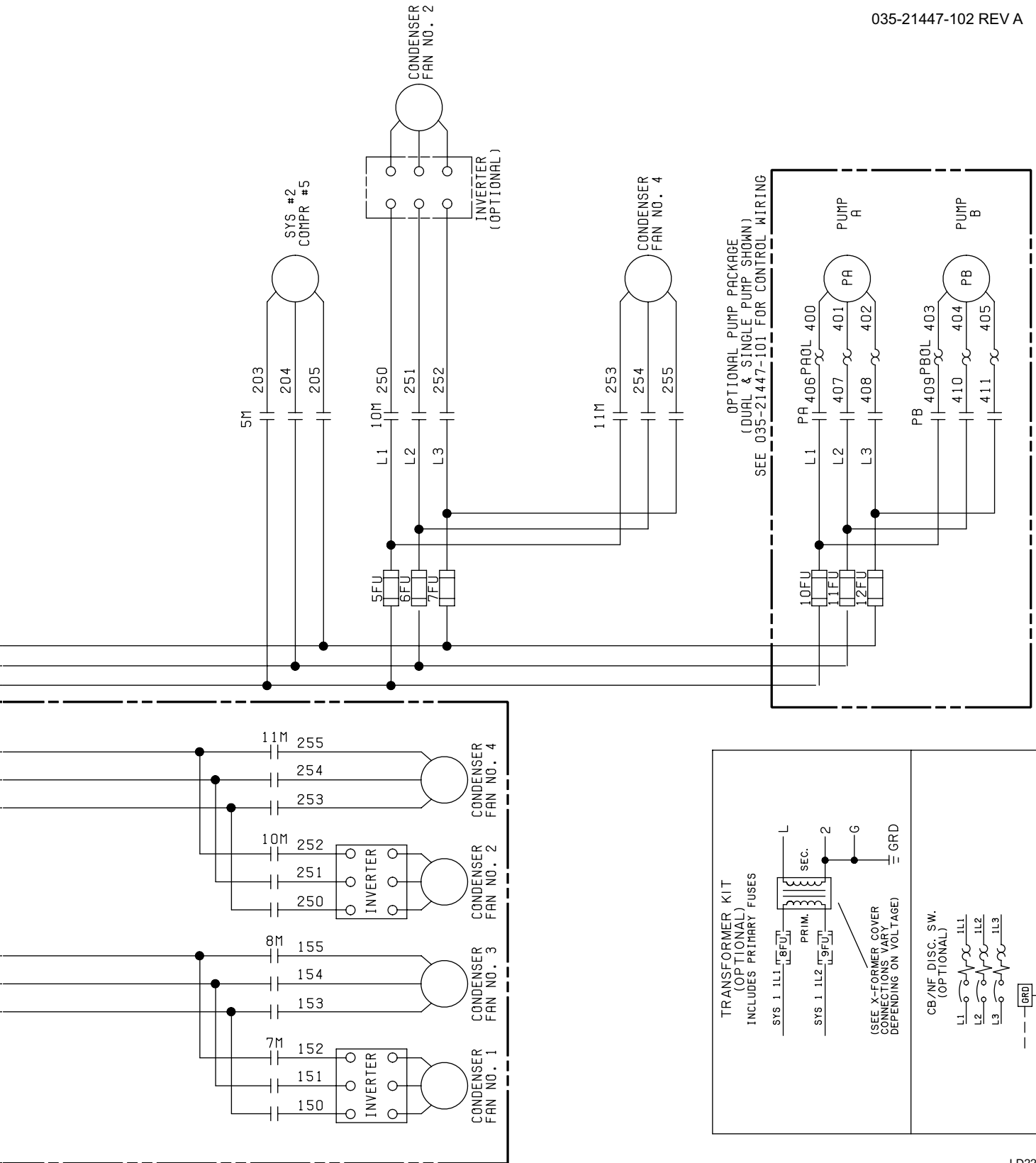
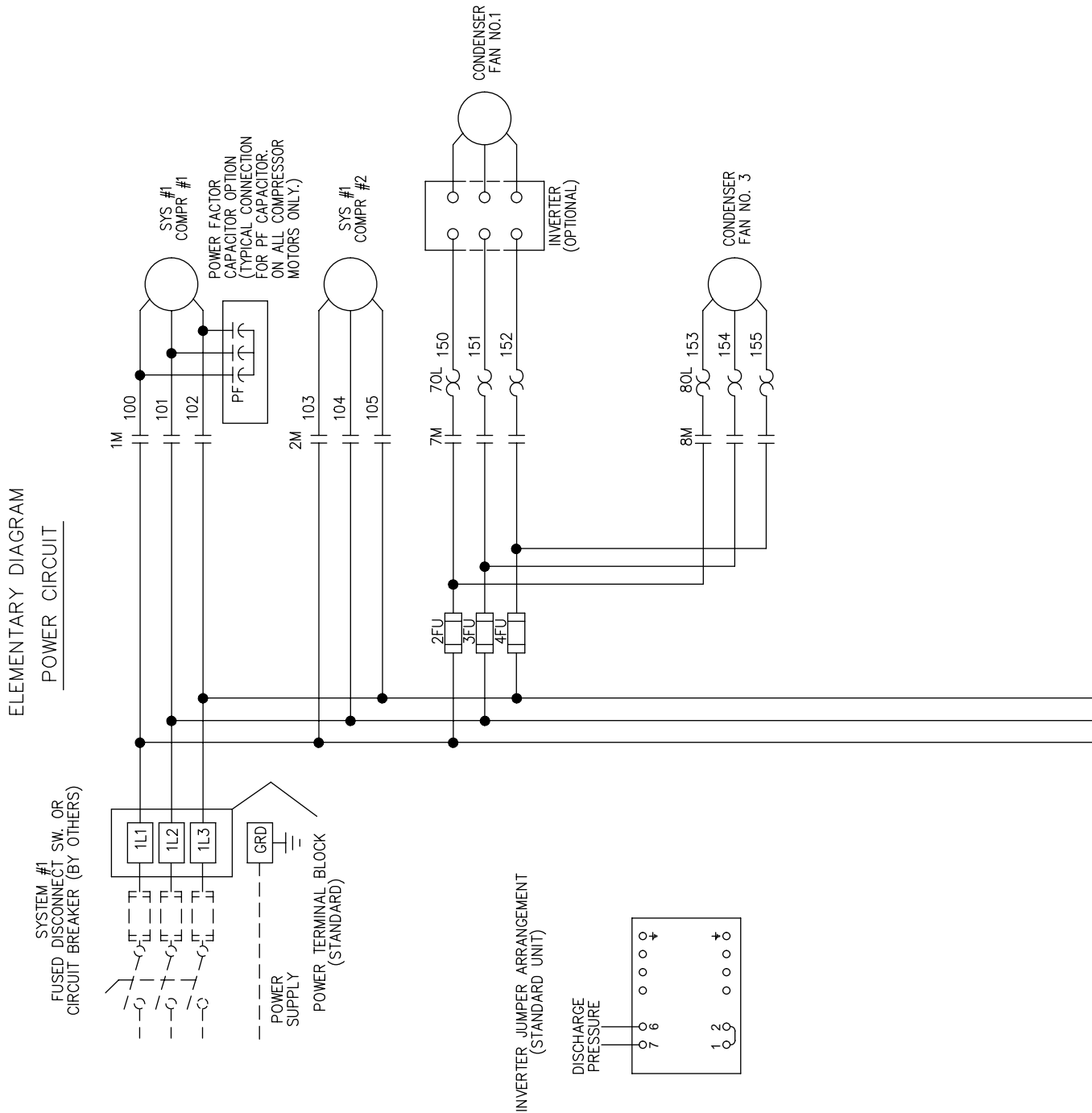

FIGURE 21 - POWER WIRING, DUAL CIRCUIT (CONT'D)

LD22106b

# QCC2060C-QCC2070C LOW SOUND QCC2040C-QCC2070C ULTRA LOW SOUND (200V, 230V, 380V AND 575V)



**FIGURE 22 - POWER WIRING, DUAL CIRCUIT**

LD22107a

035-21025-102 REV C

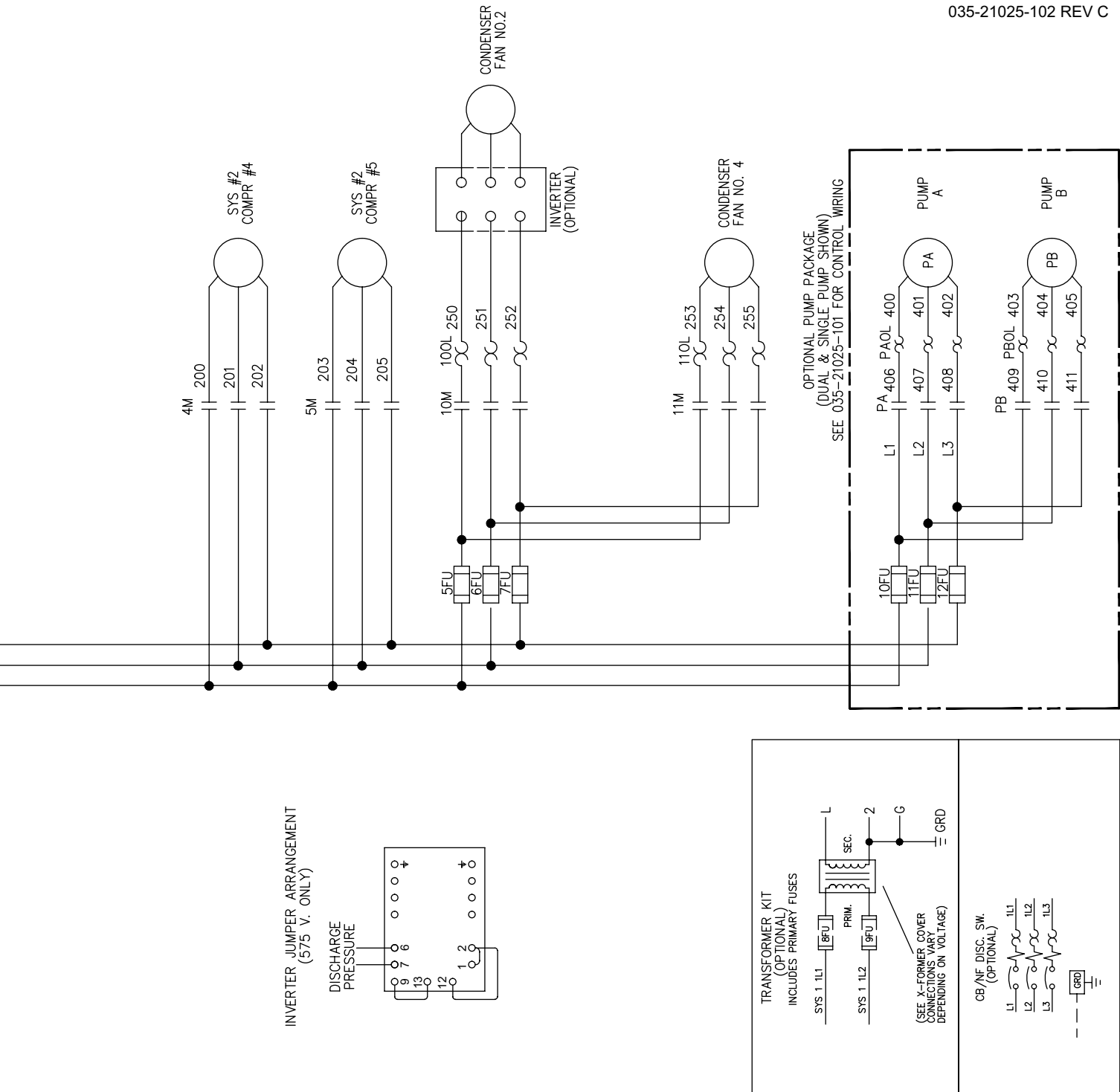

5

FIGURE 22 - POWER WIRING, DUAL CIRCUIT (CONT'D)

LD22107b

# QCC2015C-QCC2020C LOW SOUND (200V, 230V, 380V, 460V AND 575V)

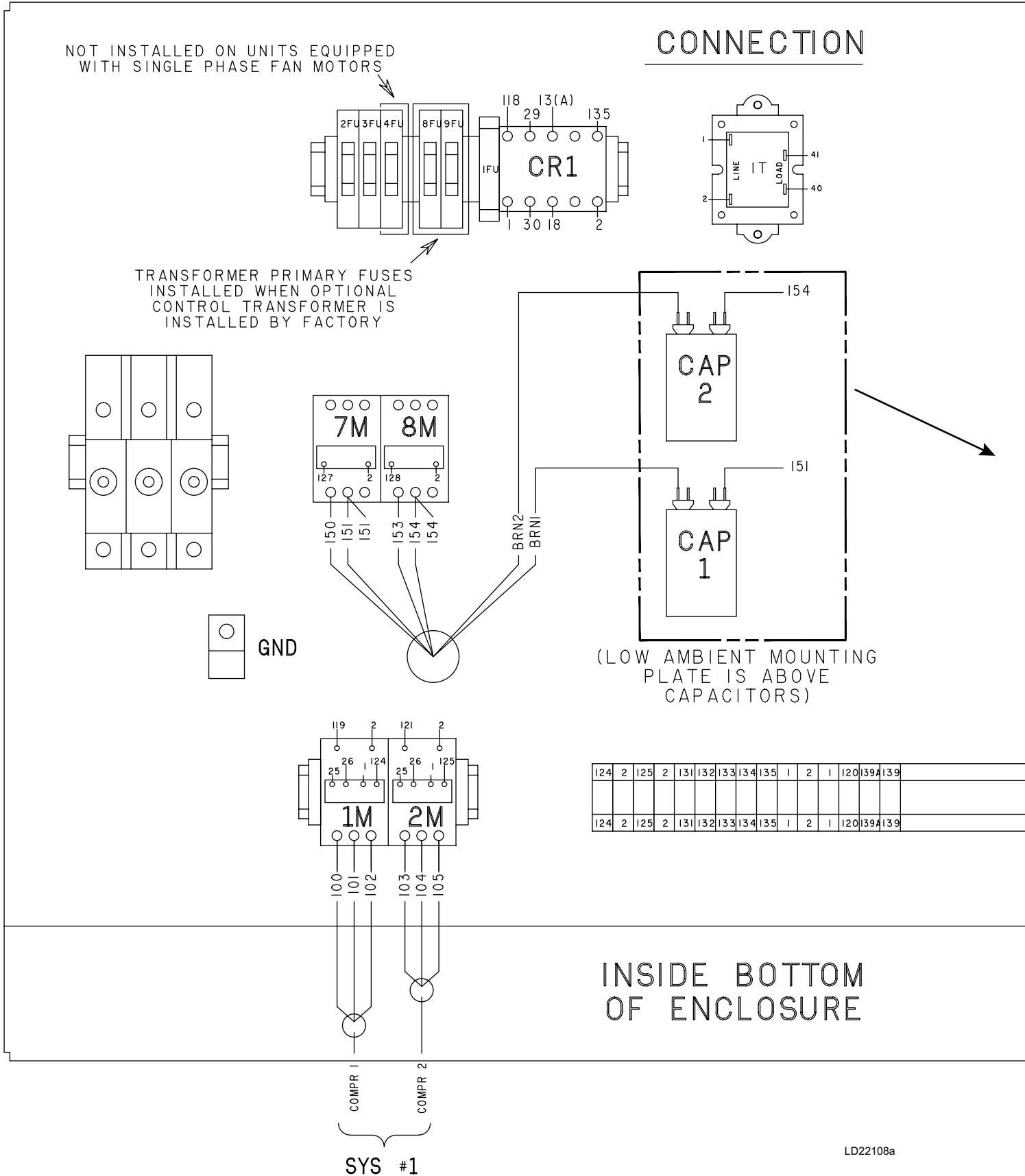
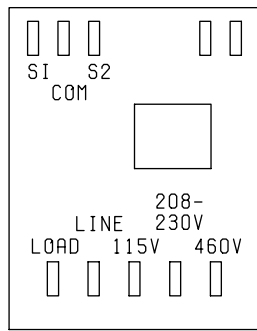
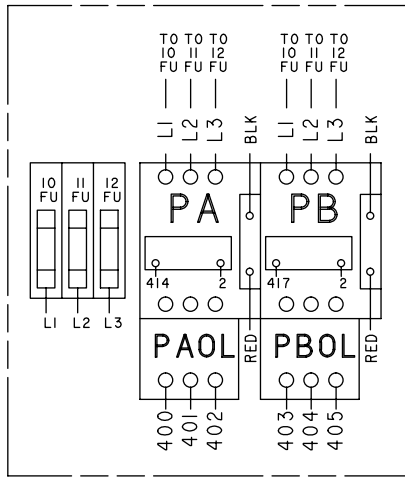

FIGURE 23 - CONNECTION WIRING, SINGLE CIRCUIT

# DIAGRAM

LOCATION AND ORIENTATION OF PUMP DETAIL  
MAY VARY DEPENDING ON MODEL  
UNITS CAN COME WITH 1 OR 2 PUMPS



LOW AMBIENT KIT  
(OPTIONAL)

TBI

	SP	SP	2	20A	2	30	29	26	25	GND	24	24	23	I	5	L	2	GND	SP	3	33	GND
	SP	SP	2	20A	2	30	29	26	25	GND	24	24	23	I	5	L	2	GND	SP	3	33	GND

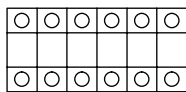

115V CONTROL GND

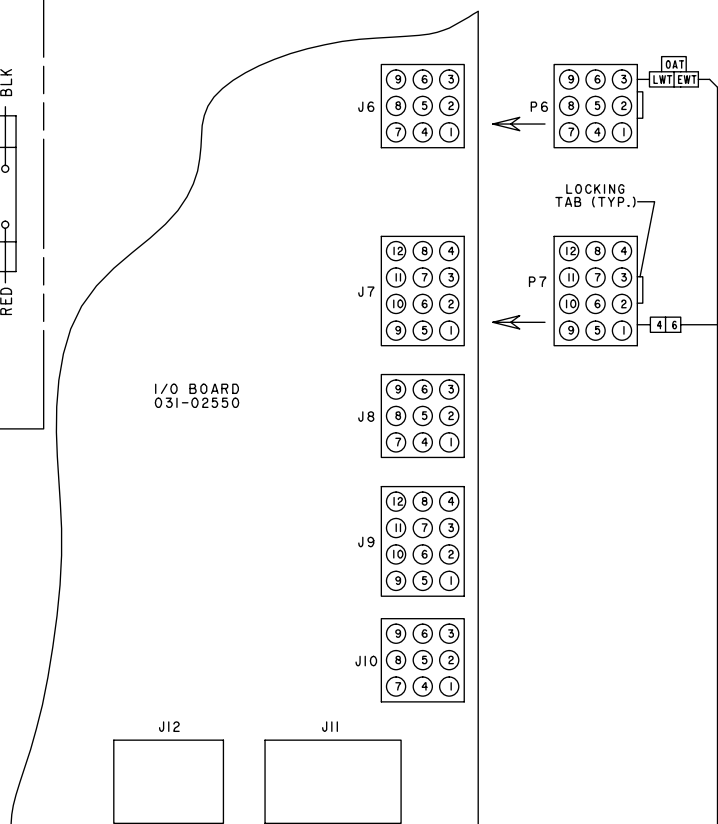
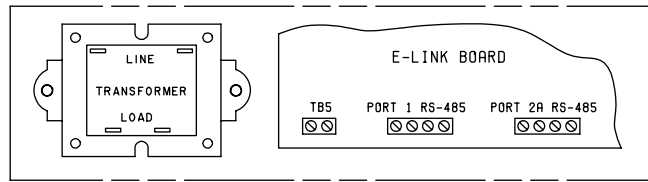
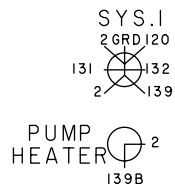
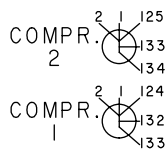

CTBI

A-
A+
51
50
21
13
20
13
19
13
18
13
17
13
16
13
14
13

5

FIGURE 23 - CONNECTION WIRING, SINGLE CIRCUIT (CONT'D)

### QCC2015C-QCC2020C LOW SOUND (380-415V/3/50)

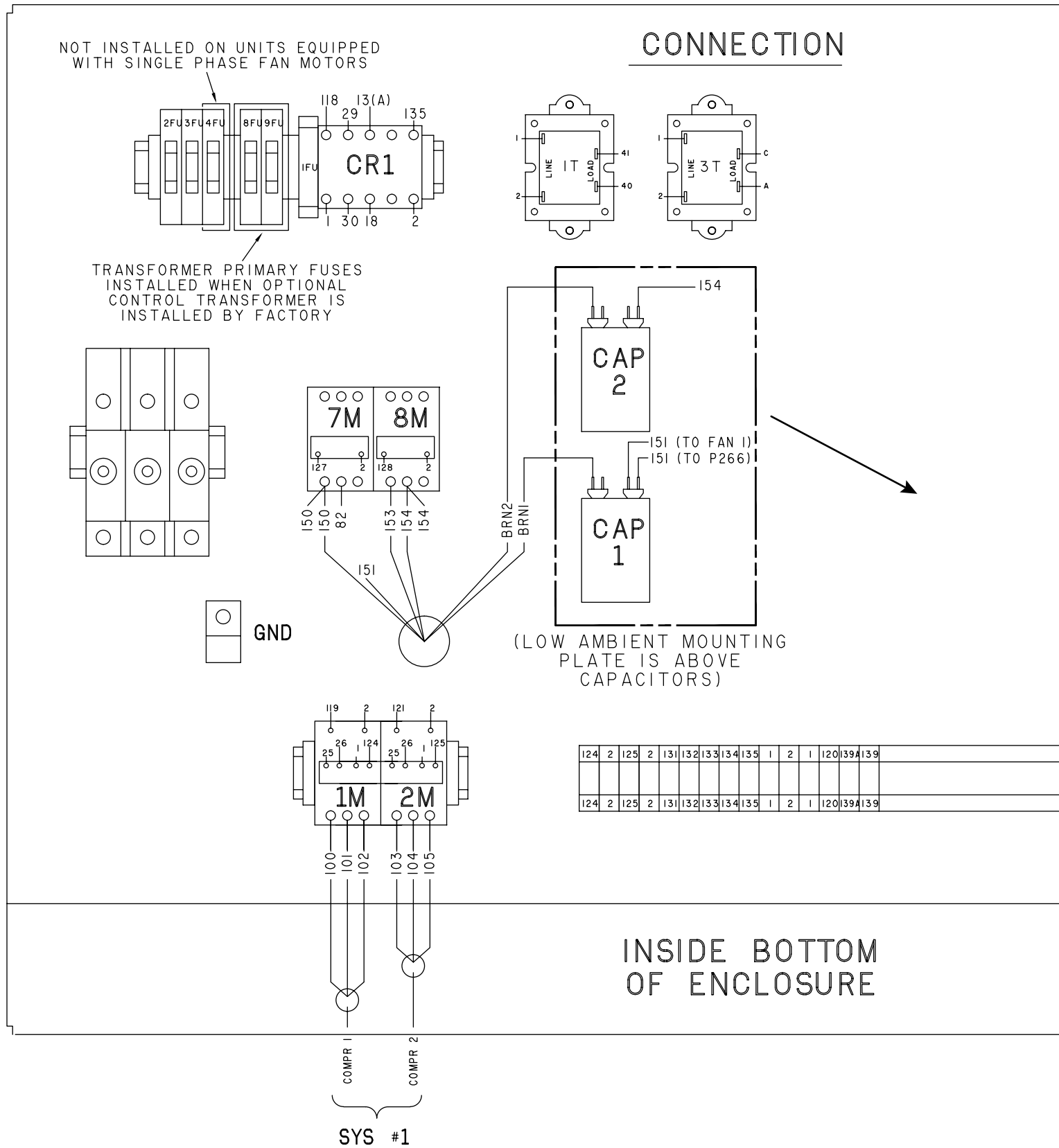

FIGURE 24 - CONNECTION WIRING, SINGLE CIRCUIT

LD22109a

035-21487-406 REV D

# DIAGRAM

LOCATION AND ORIENTATION OF PUMP DETAIL  
MAY VARY DEPENDING ON MODEL

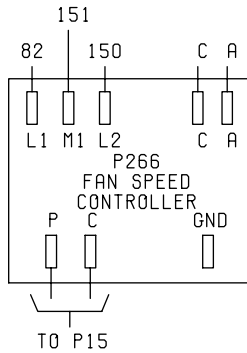
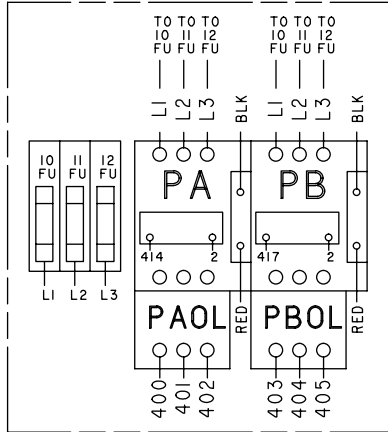

50HZ LOW AMBIENT KIT  
(OPTIONAL)

TBI

SP	SP	2	20	2	30	29	26	25	GND	24	24	23	1	5	L	2	GND	SP	33	GND
SP	SP	2	20	2	30	29	26	25	GND	24	24	23	1	5	L	2	GND	SP	33	GND

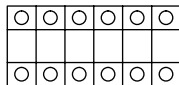

115V CONTROL GND

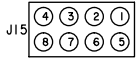
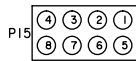
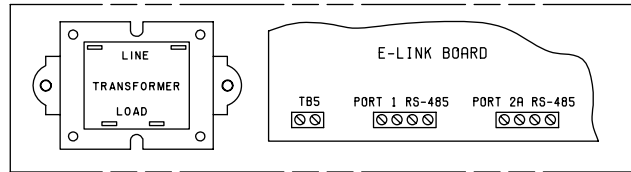
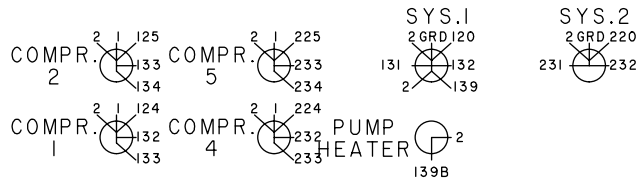

I/O BOARD  
031-02550

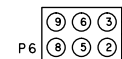
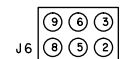

LOCKING  
TAB (TYP.)

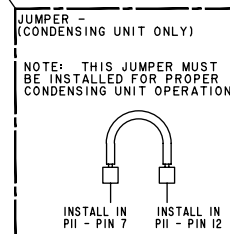
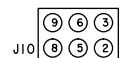
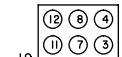
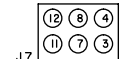
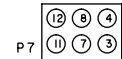

CTBI

A-
A+
51
50
21
13
20
13
19
13
18
13
17
13
16
13
14
13

5

FIGURE 24 - CONNECTION WIRING, SINGLE CIRCUIT (CONT'D)

# QCC2025C-QCC2030C LOW SOUND QCC2025C-QCC2030C ULTRA LOW SOUND (460V AND 380-415V/3/50)

NOT INSTALLED ON UNITS EQUIPPED WITH SINGLE PHASE FAN MOTORS

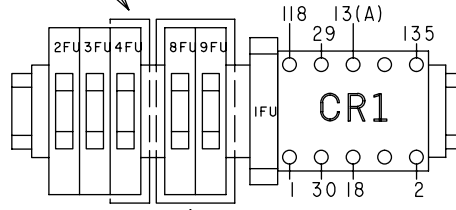

## CONNECTION

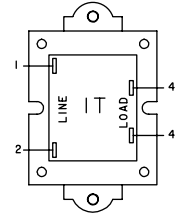

TRANSFORMER PRIMARY FUSES INSTALLED WHEN OPTIONAL CONTROL TRANSFORMER IS INSTALLED BY FACTORY

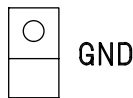
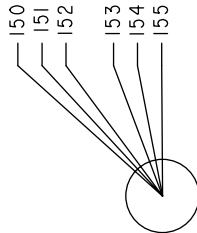
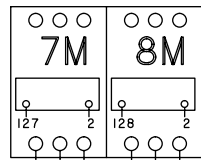
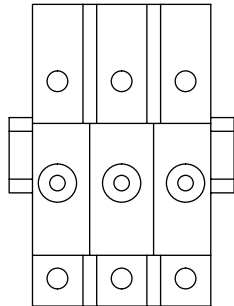

LOCATION AND ORIENTATION OF PUMP DETAIL MAY VARY DEPENDING ON MODEL

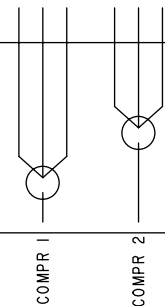
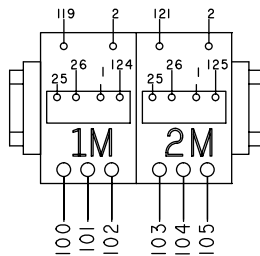
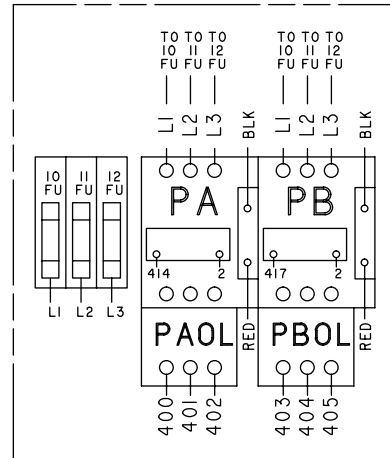

SYS #1

INSIDE BOTTOM OF ENCLOSURE

124	2	125	2	131	132	133	134	135	1	2	1	120	139	139
124	2	125	2	131	132	133	134	135	1	2	1	120	139	139

LD22110a

**FIGURE 25 - CONNECTION WIRING, SINGLE CIRCUIT**





# QCC2025C-QCC2030C ULTRA LOW SOUND (200V, 230V, 380V AND 575V)

## CONNECTION

NOT INSTALLED ON UNITS EQUIPPED WITH SINGLE PHASE FAN MOTORS

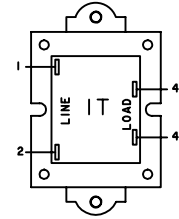
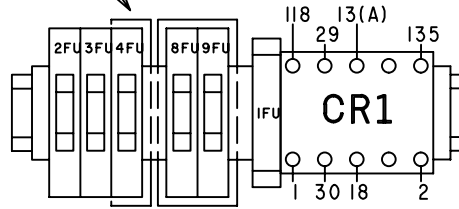

TRANSFORMER PRIMARY FUSES INSTALLED WHEN OPTIONAL CONTROL TRANSFORMER IS INSTALLED BY FACTORY

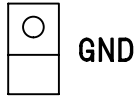
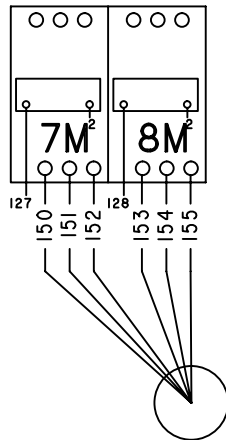
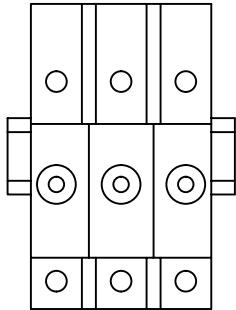

LOCATION AND ORIENTATION OF PUMP DETAIL MAY VARY DEPENDING ON MODEL

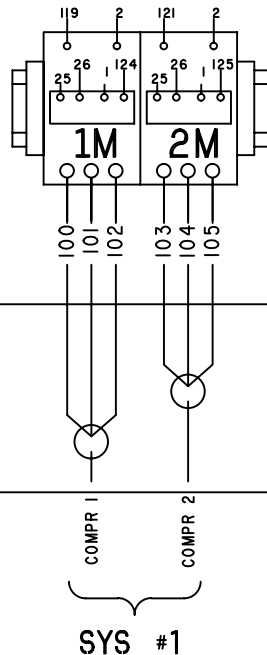
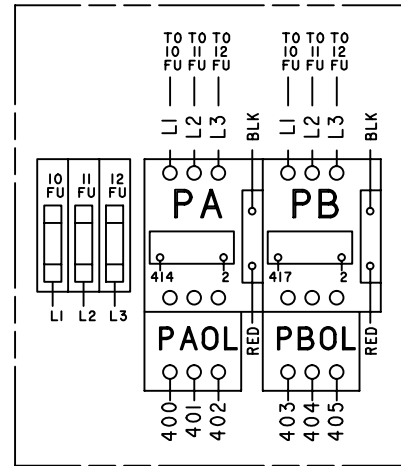

124	2	125	2	131	132	133	134	135	1	2	1	120	139	139
124	2	125	2	131	132	133	134	135	1	2	1	120	139	139

INSIDE BOTTOM OF ENCLOSURE

LD22111a

FIGURE 26 - CONNECTION WIRING, SINGLE CIRCUIT

035-21585-404 REV D

**DIAGRAM**

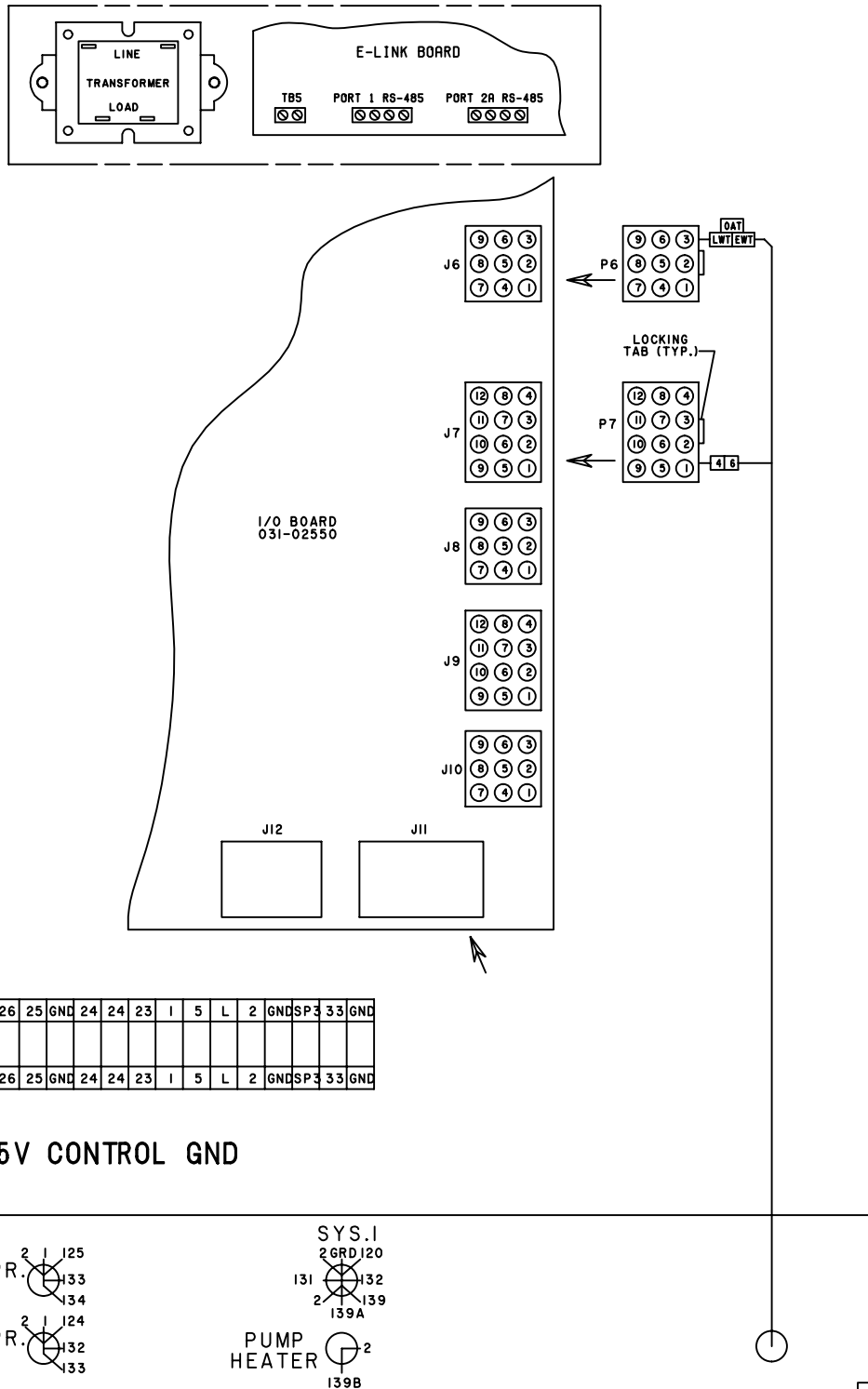

**5**

**FIGURE 26 - CONNECTION WIRING, SINGLE CIRCUIT (CONT'D)**

# QCC2040C-QCC2050C LOW SOUND QCC2040C-070C ULTRA LOW SOUND (460V AND 380-415V 50 HZ)

## CONNECTION

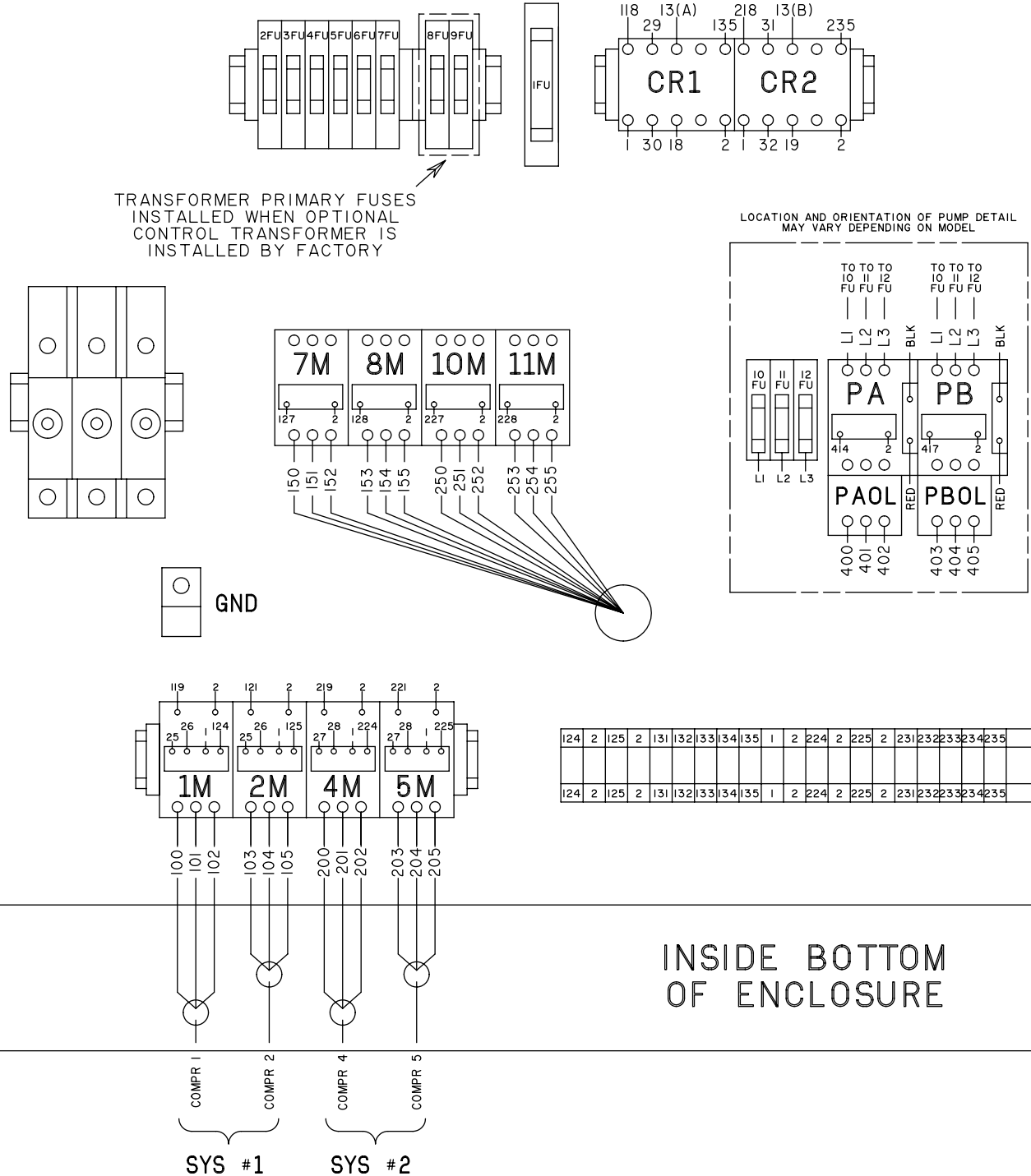
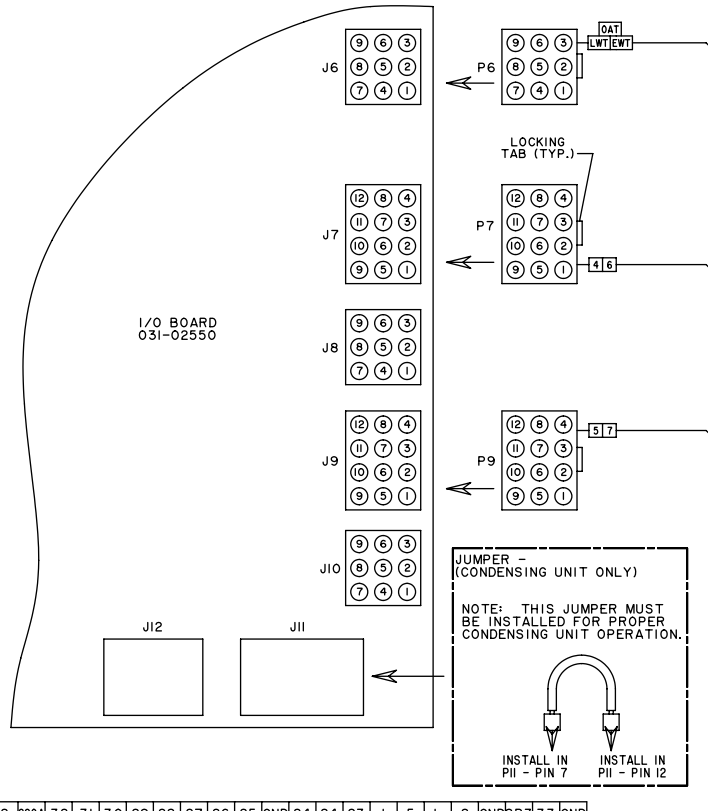
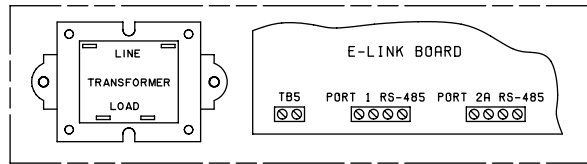
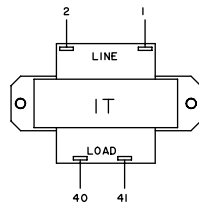

**FIGURE 27 - CONNECTION WIRING, DUAL CIRCUIT**

LD22112a

035-21447-404 REV B

DIAGRAM



TBI

1	2	120	220	139	SP1	SP2	20A	2	220A	32	31	30	29	28	27	26	25	GND	24	24	23	1	5	L	2	GND	SP3	33	GND
1	2	120	220	139	SP1	SP2	20A	2	220A	32	31	30	29	28	27	26	25	GND	24	24	23	1	5	L	2	GND	SP3	33	GND

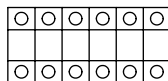

115V CONTROL GND

CTBI

A-
A+
51
50
21
13
20
13
19
13
18
13
17
13
16
13
14
13

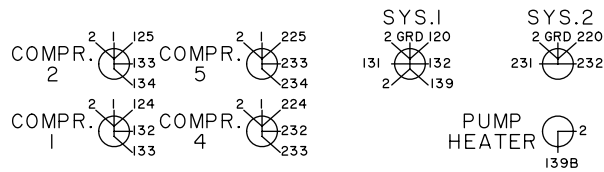

LD22112b

FIGURE 27 - CONNECTION WIRING, DUAL CIRCUIT (CONT'D)

# QCC2060C-QCC2070C LOW SOUND QCC2040C-070C ULTRA LOW SOUND (200V, 230V, 380V AND 575V)

## CONNECTION

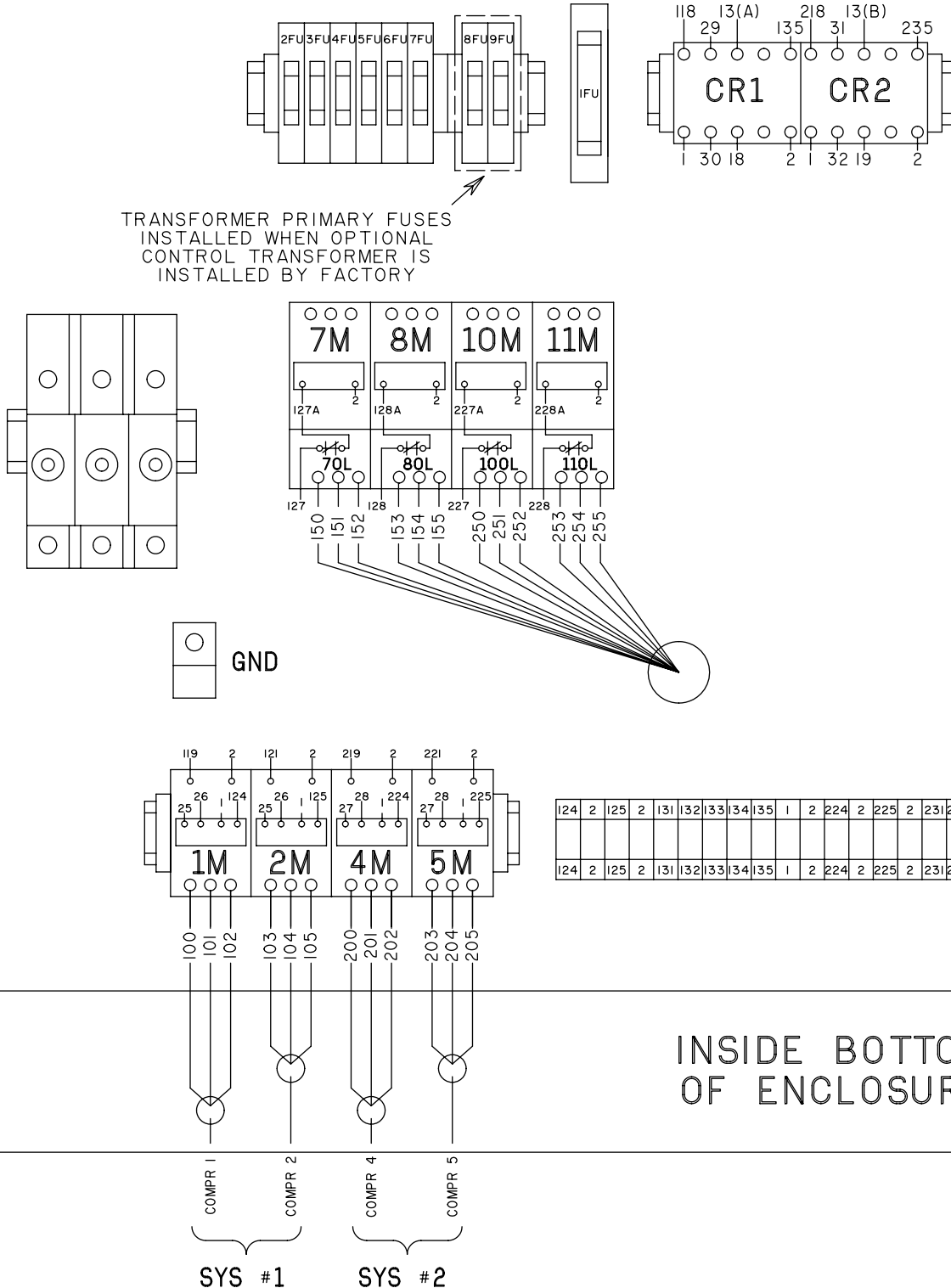
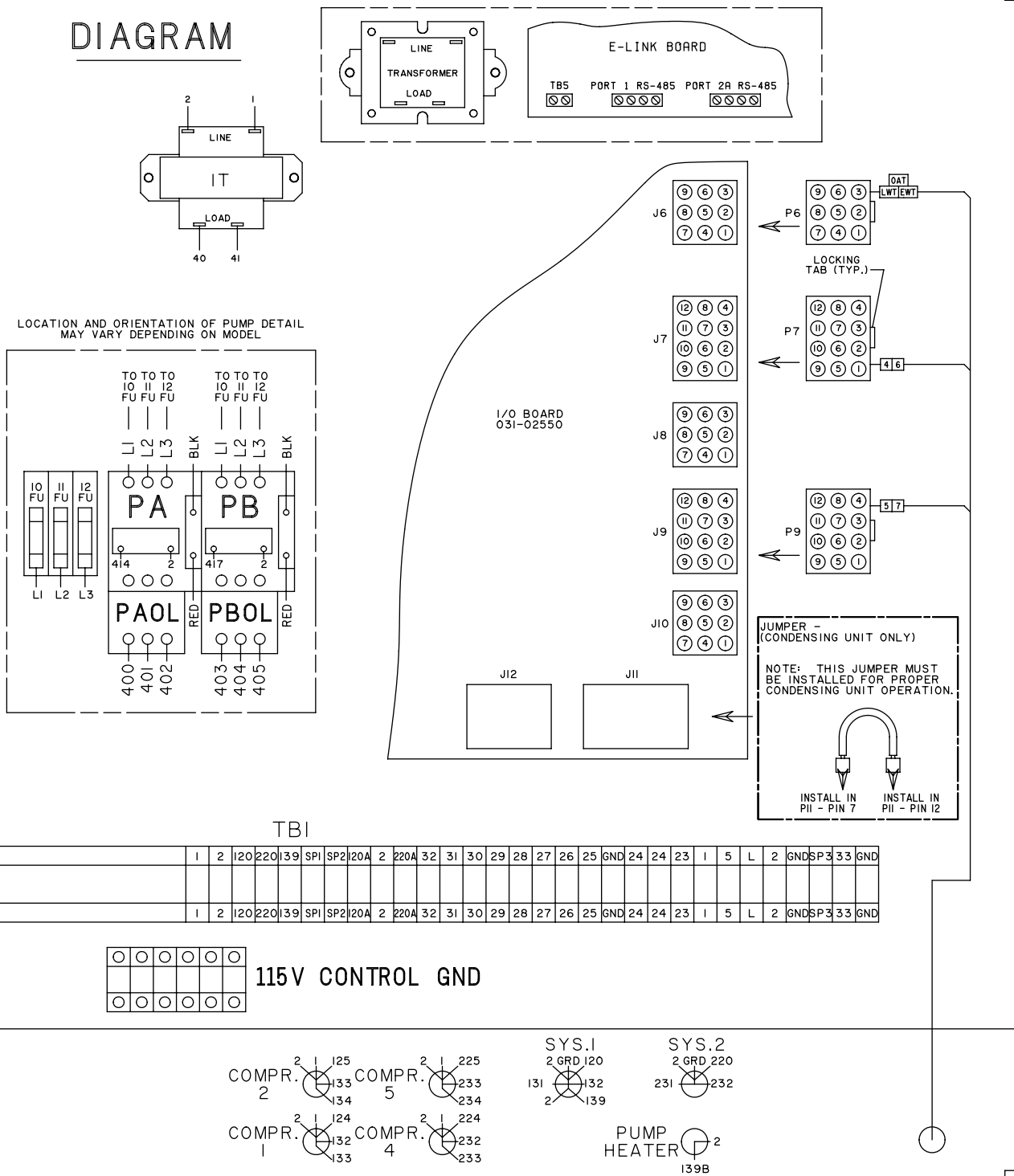

**FIGURE 28 - CONNECTION WIRING, DUAL CIRCUIT**

LD22113a

035-21586-404 REV B

DIAGRAM



5

- CTBI
- A-
  - A+
  - 51
  - 50
  - 21
  - 13
  - 20
  - 13
  - 19
  - 13
  - 18
  - 13
  - 17
  - 13
  - 16
  - 13
  - 14
  - 13

TABLE 28 - CONNECTION WIRING, DUAL CIRCUIT (CONT'D)

## DIMENSIONS (ENGLISH) DIMENSIONS – QCC2015C TO 070C (ENGLISH)

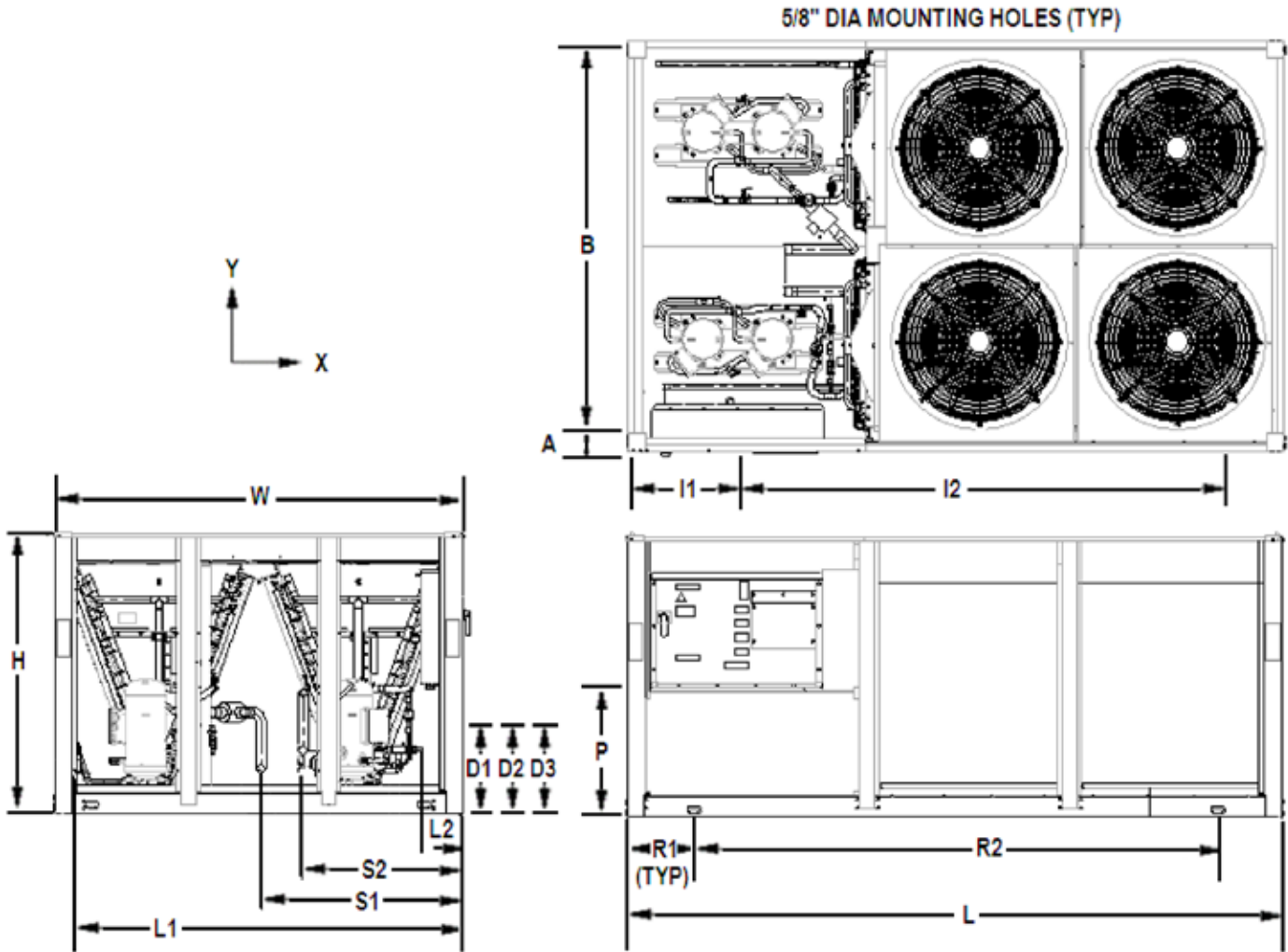

All dimensions in English unless otherwise noted.

**NOTE:**

Placement on a level surface of free of obstructions (including snow, for winter operation) or air circulation ensures rated performance, reliable operation, and ease of maintenance. Site restrictions may compromise minimum clearances indicated below, resulting in unpredictable airflow patterns and possible diminished performance. Quantech unit controls will optimize operation without nuisance high-pressure safety cutouts; however, the system designer must consider potential performance degradation. Access to the unit control center assumes the unit is no higher than on spring isolators. Recommended minimum clearances: Side to wall – 6"; rear to wall – 6"; control panel to end wall – 4'0"; top – no obstructions allowed; distance between adjacent units – 10'. No more than one adjacent wall may be higher than the unit.



## DIMENSIONS – QCC2015C TO 070C (ENGLISH)

60 HZ MODEL		015CEE	020CEE	025CEE	030CEE	040CEE	045CEE	050CEE	060CEE	070CEE
<b>Length</b>	<b>L</b>	109.79	109.79	118.6	118.6	144.8	144.8	148.8	148.8	153.6
<b>Width</b>	<b>W</b>	44.7	44.7	44.7	44.7	90.6	90.6	90.6	90.6	90.6
<b>Height</b>	<b>H</b>	46.06	46.06	46.06	50	47.8	47.8	62.6	62.6	62.6
	<b>F</b>									
	<b>P</b>	12.7	12.7	12.7	16.7	13.6	13.6	28.5	28.5	28.5
<b>Connection Sizes</b>	<b>Suction In 1</b>	1.6	1.6	2.1	2.1	2.1	2.1	2.1	2.1	2.3
	<b>Suction In 2</b>									
	<b>Liquid Out 1 / 2</b>	0.9	0.9	1.1	1.1	1.1	1.1	1.1	1.1	1.1
<b>System 1 Dimensions</b>	<b>Suction In</b>	37.7	37.7	6.2	3.9	48.7	48.7	52.7	44.4	53.7
	<b>Liquid Out</b>	31.7	31.7	23.1	34.6	72.9	72.9	85.1	85.1	77.6
<b>System 2 Dimensions</b>	<b>Suction In</b>					41.6	41.6	35.1	35.1	33.3
	<b>Liquid Out</b>					17.3	17.3	14.1	14.1	15
	<b>D1</b>	30.4	30.4	28.9	19.8	19.6	19.7	24	9.7	6.8
	<b>D2</b>	6.0	6.0	6.5	5.8	6.4	6.4	9.1	9.1	5.3
	<b>D3</b>							13.8	13.8	9.2
	<b>D4</b>									
<b>Isolator Location Dimensions</b>	<b>I1</b>	17	17	17	17	9.8	9.8	9.8	9.8	9.8
	<b>I2</b>	104.2	104.2	113.3	113.3	135	135	135	135	143.8
	<b>I3</b>									
	<b>I4</b>									
	<b>I5</b>									
	<b>I6</b>									
	<b>I7</b>									
	<b>I8</b>									
	<b>A</b>	1.1	1.1	1.1	1.1	1.1	1.1	1.1	1.1	1.1
	<b>B</b>	43.3	43.3	43.3	43.3	89.5	89.5	89.5	89.5	89.5
<b>Rigging Hole Locations</b>	<b>R1</b>	15.6	15.6	15.6	15.6	15.1	15.1	15.1	15.1	15.1
	<b>R2</b>	97.1	97.1	105.1	105.1	130.9	130.9	130.9	130.8	137.6
	<b>R3</b>									
	<b>R4</b>									
<b>Unit COG</b>	<b>X</b>	58.6	58.5	63.1	67.1	59.6	59.2	61.9	61.5	59.7
	<b>Y</b>	22.9	22.9	22.9	23.1	43.6	43.5	42.2	42.2	44.9

5

### CLEARANCES

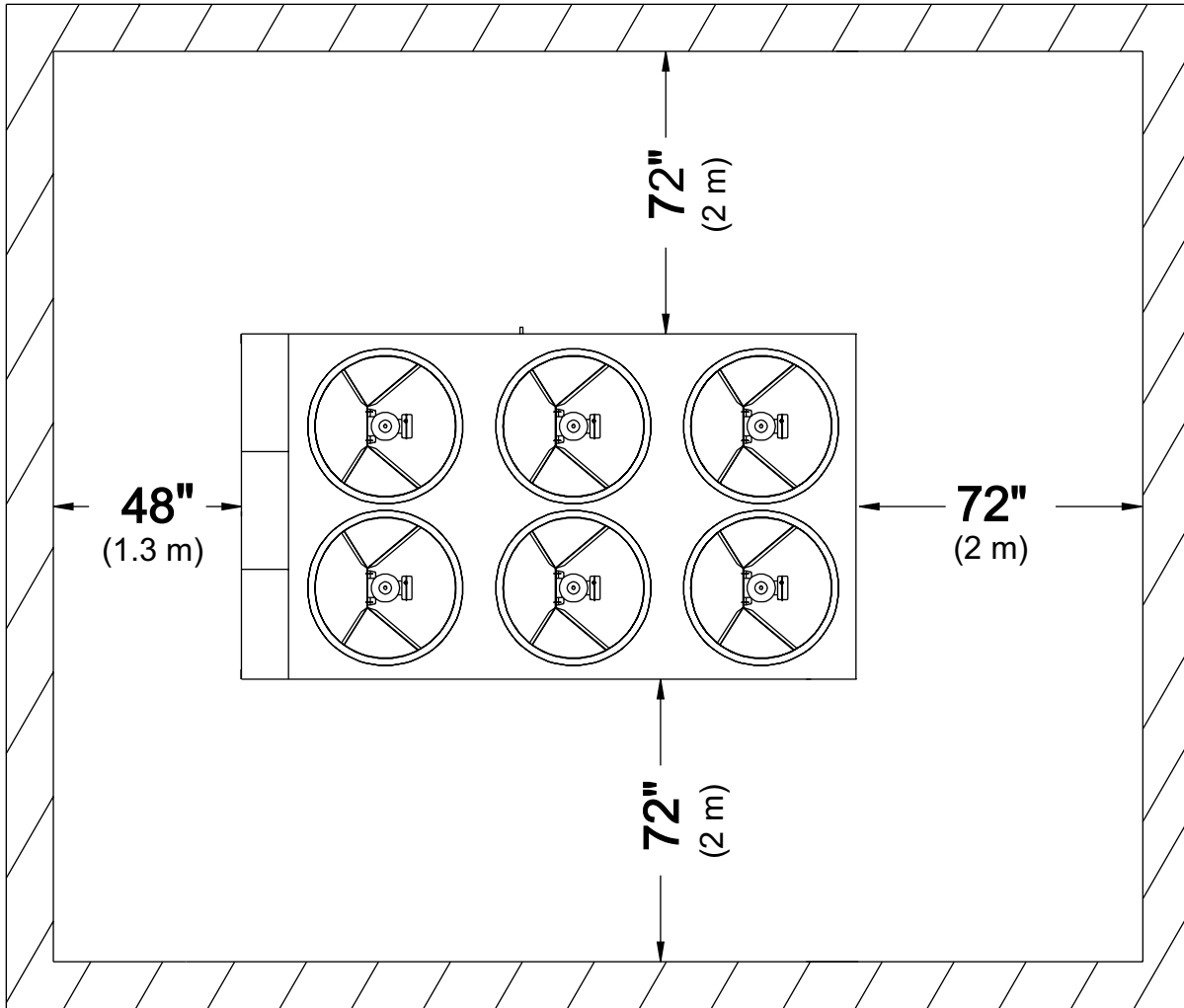

LD13243

**NOTES:**

- 1.No obstructions allowed above the unit.
- 2.Only one adjacent wall may be higher than the unit.
- 3.Adjacent units should be 10 feet (3 Meters) apart.

**FIGURE 29 - UNIT CLEARANCES – ALL MODELS**

## WEIGHT DISTRIBUTION AND ISOLATOR MOUNTING POSITIONS

### General

Weights of specific chiller models vary significantly as options are added. As a result, total weights, weights at individual isolator positions, and actual isolator selection at each position cannot be published due to the vast number of possible combinations. This information will be available when the specific chiller/ option selection is made from the local Quantech Sales Representative. Be aware, weights will change with each option along with possible isolator changes. Weights and isolators may need to be recalculated when the option selections are changed.

Whenever the isolator option is ordered, the isolators will be shipped loose with the chiller. Packed with the isolators and also in the control panel information packet is a drawing and table specifically for each chiller, based on the option selection. The drawing and table will be similar to the sample shown below. The drawing will show the isolator locations along with the weight in pounds and kilograms at the specific location, isolator position, and location measurements for each isolator.

Order No: 082533060301  
 Line No: 1  
 Product: QCC2  
 Model: QCC2040CEE46XEA  
 Voltage: 46

<b>Unit Shipping Weight</b> (Display on unit data nameplate)	<b>kg</b>	<b>lbs.</b>
	1334.5	2942

5

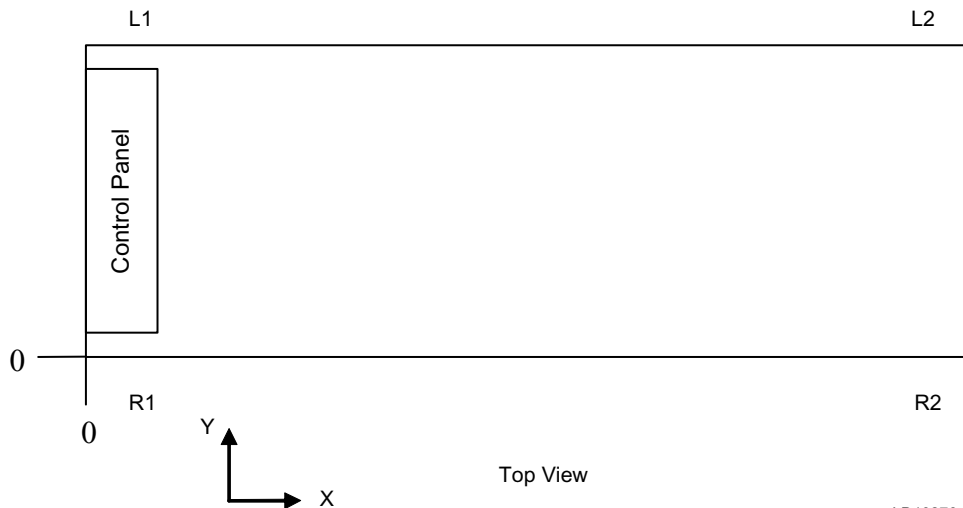

LD13276

Location	X Distance inches (mm)	Y Distance inches (mm)	Vendor Number	Operating Weight lbs (kg)
R1	9.8 (248.9)	1.1 (27.9)	ND-D / Yellow	1312 (595.1)
L1	9.8 (248.9)	89.5 (2273.2)	ND-DS / Yellow	1843 (836.0)
R2	135 (3429)	1.1 (27.9)	ND-D / Yellow	1280 (580.6)
L2	135 (3429)	89.5 (2273.2)	ND-DS / Yellow	1793 (813.3)

**SAMPLE PRINTOUT SUPPLIED IN THE ISOLATOR PACKAGE AND IN THE CHILLER PANEL LITERATURE PACKET.**

**FIGURE 30 - SAMPLE ISOLATOR LOCATION DRAWING**

### ISOLATOR LOCATIONS (ENGLISH)

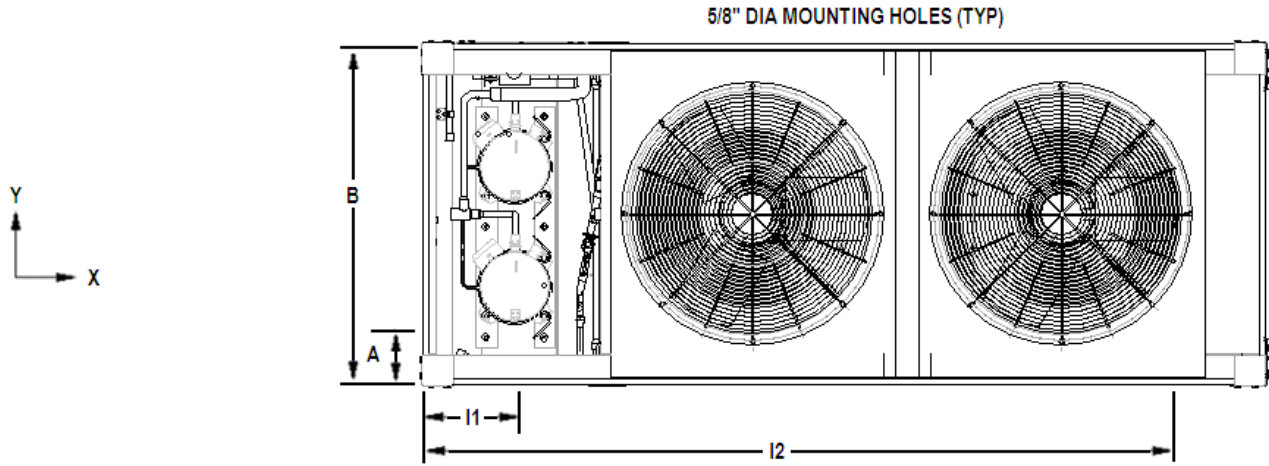

60 HZ Model		QCC2015CEE	QCC2020CEE	QCC2025CEE	QCC2030CEE
Isolator Location Dimensions	I1	17	17	17	17
	I2	104.2	104.2	113.3	113.3
	A	1.1	1.1	1.1	1.1
	B	43.3	43.3	43.3	43.3

FIGURE 31 - ISOLATOR LOCATIONS, 60 HZ

## ISOLATOR INFORMATION

### One Inch Deflection Spring Isolator Cross-reference

**CP**

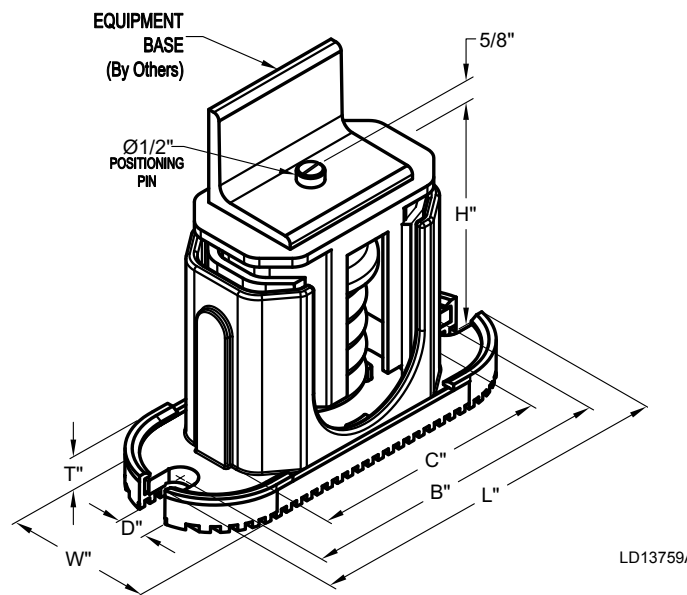

MOUNT TYPE	DIMENSION DATA (INCHES)						
	W	D	L	B	C	T	H
CP1	3	5/8	7-3/4	6-1/2	4-3/4	1/2	5-5/8
CP2	3	5/8	10-1/2	9-1/4	7-3/4	9/16	6

MODEL NUMBER	RATED CAPACITY (LBS.)	DEFLECTION RATED (IN)	COLOR CODE
CP1-1D-85	85	1.360	LT. PURPLE
CP1-1D-120	120	1.200	DK. YELLOW
CP1-1D-175	175	1.170	DK. BLUE
CP1-1D-250	250	1.400	YELLOW
CP1-1D-340	340	1.130	RED
CP1-1D-510	510	1.020	BLACK
CP1-1D-675	675	1.320	DK. PURPLE
CP1-1D-900	900	1.020	DK. GREEN
CP1-1D-1200	1200	0.900	GRAY
CP1-1D-1360	1360	0.770	WHITE
CP1-1D-1785N	1785	0.880	GRAY/RED

MODEL NUMBER	RATED CAPACITY (LBS.)	DEFLECTION RATED (IN)	COLOR CODE
CP2-1D-1020	1020	1.020	BLACK
CP2-1D-1350	1350	1.320	DK. PURPLE
CP2-1D-1800	1800	1.020	DK. GREEN
CP2-1D-2400	2400	0.900	GRAY
CP2-1D-2720	2720	0.770	WHITE
CP2-1D-3570N	3570	0.880	GRAY / RED

**FIGURE 32 - ONE INCH DEFLECTION SPRING ISOLATOR CROSS-REFERENCE**

## ONE INCH DEFLECTION SPRING ISOLATORS INSTALLATION INSTRUCTIONS

1. Read instructions in their entirety before beginning installation.
2. Isolators are shipped fully assembled and are to be positioned in accordance with the submittal drawings or as otherwise recommended.
3. Set isolators on floor, housekeeping pad or sub-base, ensuring that all isolator centerlines match the equipment mounting holes. The VMC group recommends that the isolator base ("B") be installed on a level surface. Shim or grout as required, leveling all isolator bases to the same elevation (1/4-inch maximum difference can be tolerated).
4. Bolt or anchor all isolators to supporting structure utilizing base slotted holes ("C").
5. Place equipment on top of isolators making sure that mounting holes of the equipment line up with isolator positioning pin ("H").
6. The adjustment process can only begin after the equipment or machine is at its full operating weight.
7. Adjust each isolator in sequence by turning spring adjusting bolt ("D") one full counterclockwise turn at a time. Repeat this procedure on all isolators, one at a time.
8. Continue adjusting each isolator until a minimum of 1/4" clearance is achieved between the lower housing and upper housing. (See drawing below).
9. Fine adjust isolators to level equipment.
10. Installation is complete.

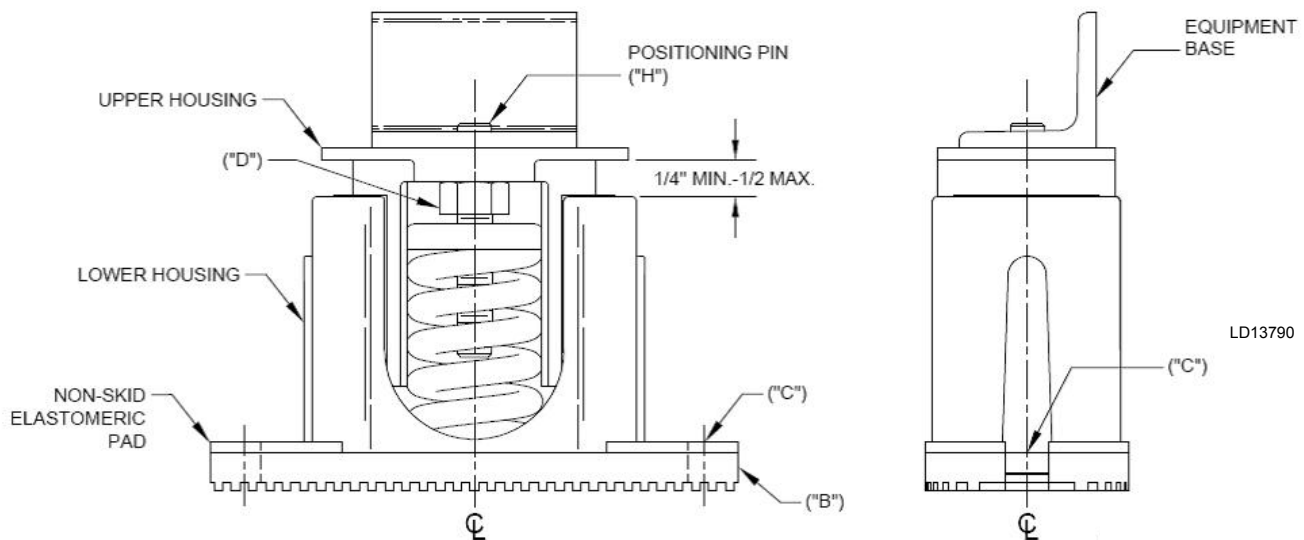

**FIGURE 33 - ONE INCH DEFLECTION SPRING ISOLATORS INSTALLATION INSTRUCTIONS**

## TWO INCH DEFLECTION SEISMIC ISOLATOR CROSS-REFERENCE

### Y2RS

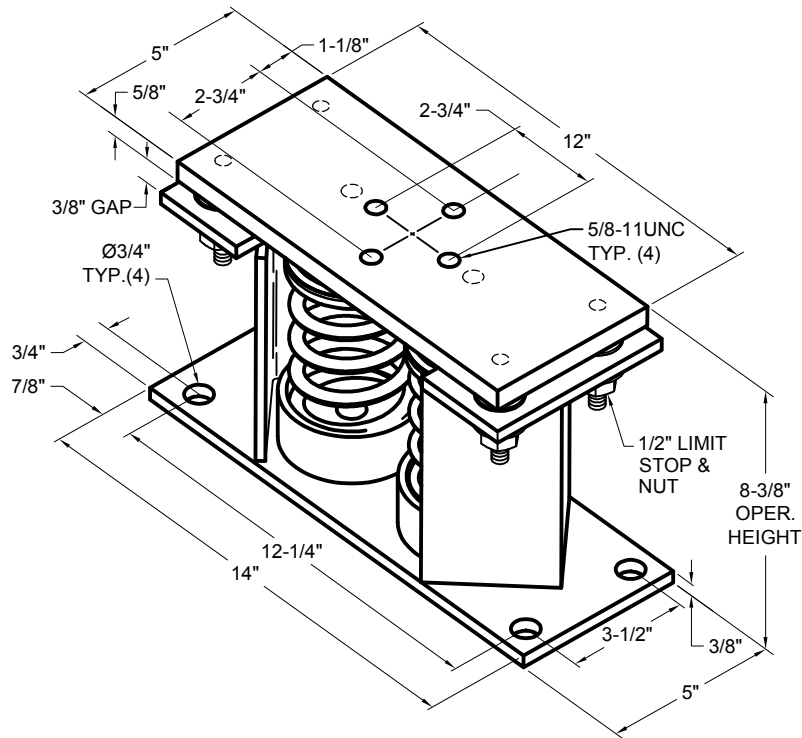

LD13761A

MODEL Y2RSI-2D SEISMICALLY RESTRAINED VIBRATION ISOLATOR FOR 2" DEFLECTION						
SEISMIC MOUNT SIZE	RATED LOAD (LBS)	RATED DEFLECTION (IN)	SPRING RATE (LBS/IN)	SOLID LOAD (LBS)	COLOR CODE	ALLOWABLE G RATING HORIZONTAL
Y2RSI-2D-150	150	2.4	62	234	WHITE	34.7
Y2RSI-2D-320	320	2.3	140	490	YELLOW	16.3
Y2RSI-2D-460	460	2.3	200	688	GREEN	11.3
Y2RSI-2D-710	710	2.2	330	1072	DK BROWN	7.3
Y2RSI-2D-870	870	1.9	460	1312	RED	6
Y2RSI-2D-1200N	1200	1.9	638	1818	RED/BLACK	4.3
Y2RSI-2D-1450	1450	1.8	900	2450	TAN	3.6
Y2RSI-2D-1690	1690	1.7	1140	2892	PINK	3.1
Y2RSI-2D-2000N	2000	1.7	1318	3342	PINK/BLACK	2.6
Y2RSI-2D-2640N	2640	1.5	1854	4283	PINK/GRAY	2
Y2RSI-2D-2870N	3080	1.5	2004	4629	PINK/GRAY/ORANGE	1.7
Y2RSI-2D-3280N	3740	1.8	2134	4930	PINK/GRAY/DK BROWN	1.4

**NOTES:**

- 1.All dimensions are in inches, interpret per ANSI Y14.
- 2.Standard finish: housing-powder coated (color, black), spring-powder coated (color, see table) hardware - zinc-electroplate.
- 3.Equipment must be bolted or welded to the top plate to meet allowable seismic ratings.
- 4.All springs are designed for 50% overload capacity with exception of the 2D-3280N and 2D-2870.
- 5.Refer to next page for installation instructions.
- 6.Consult factory for concrete installation.

**FIGURE 34 - TWO INCH DEFLECTION SEISMIC ISOLATOR CROSS-REFERENCE**

## SEISMIC ISOLATOR INSTALLATION AND ADJUSTMENT

1. Read instructions in their entirety before beginning installation.
2. Isolators are shipped fully assembled and are to be positioned in accordance with the submittal drawings or as otherwise recommended.
3. Set isolators on floor, housekeeping pad, or sub-base, ensuring that all isolator centerlines match the equipment mounting holes. The VMC group recommends that the isolator base plates ("B") be installed on a level surface. Shim or grout as required, leveling all isolator base plates to the same elevation (1/4-inch maximum difference can be tolerated).
4. Bolt or anchor all isolators to supporting structure utilizing base plate thru holes ("C") or weld base plate to supporting structure with 3/8 fillet weld 2" long @ 4" on center around entire base plate or as engineered for specific load and or field conditions.
5. Isolators are shipped to the job site with (2) removable spacer shims ("E") between the top plate and the housing. These shims must be in place when the equipment is positioned over the isolators.
6. With all shims ("E") in place, position equipment on top of plate ("A") of isolator. Bolt equipment securely to top plate of isolator using a minimum of (2) 5/8 UNC A325 grade 5 SAE bolts or weld equipment or bracket to the top plate ("A") of isolator with a minimum of 3/8 fillet welds 2" long @ 3" on center for a minimum total weld of 10". (All sides of equipment or bracket resting on top plate ("A") must be welded).
7. The adjustment process can only begin after the equipment or machine is at its full operating weight.
8. Back off each of the (4) limit stop lock nuts ("F") on isolators 1/2".
9. Adjust each isolator in sequence by turning spring adjusting nuts ("G") one full clockwise turn at a time. Repeat this procedure on all isolators, one at a time. Check the limit stop lock nuts ("F") periodically to ensure that clearance between the washer and rubber grommet is maintained. Stop adjustment of isolator only when the top plate ("A") has risen just above the shim ("E").
10. Remove all spacer shims ("E").
11. Fine adjust isolators to level equipment.
12. Adjust all limit stop lock nuts ("F") per isolator, maintaining 1/4-to 3/8-inch gap. The limit stop lock nuts must be kept at this gap to ensure uniform bolt loading during uplift (as the case when equipment is drained).
13. Installation is complete.

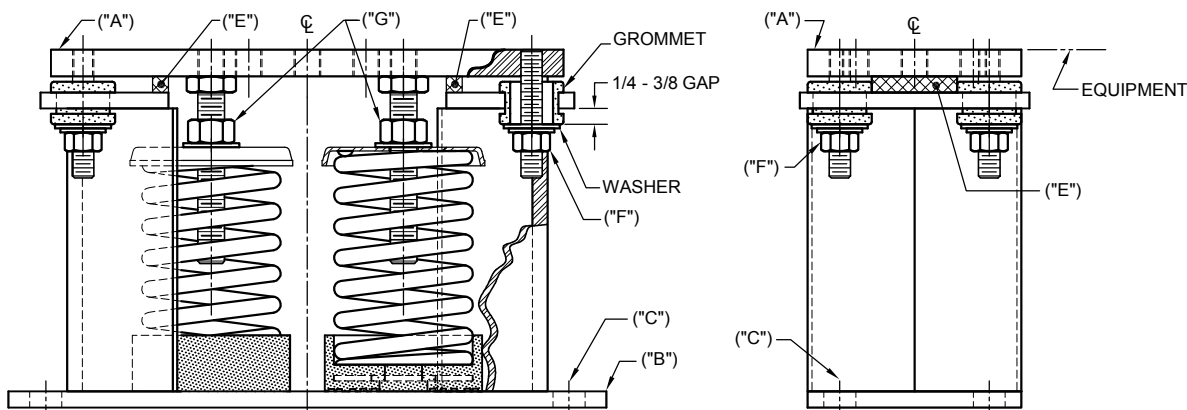

LD13763B

FIGURE 35 - SEISMIC ISOLATOR INSTALLATION AND ADJUSTMENT



## DURULENE ISOLATOR CROSS-REFERENCE

### RD-Style Isolators

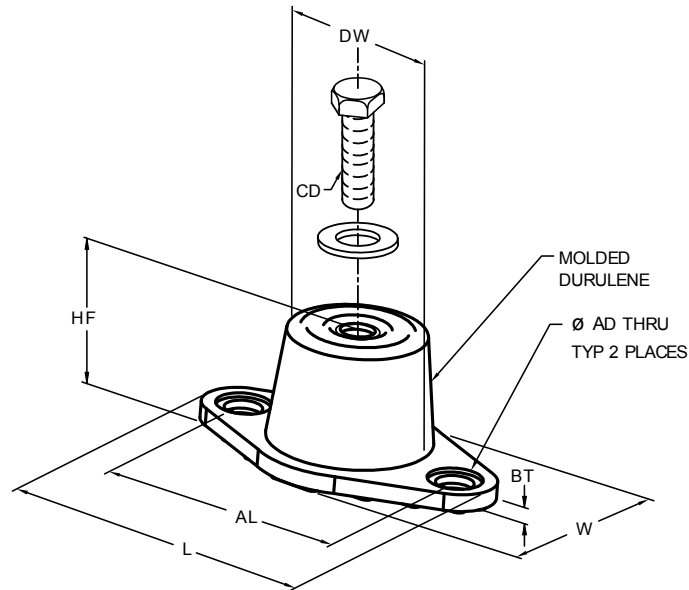

**NOTES:**

1. All dimensions are inches, interpreted per ANSI Y14.
2. Refer to next page for installation instructions.
3. Mount molded in weather resistant duralene compound as standard. Also available in other materials such as natural rubber, extreme high temperature silicone, high-damped silicone, nitrile and EDPM.
4. AL = Mounting hole center to center spacing.
5. HF = Free height of mount, prior to loading. Operating height calculated by the free height less the static deflection under load. All dimensions for reference only.
6. Hardware is zinc-electroplated.

5

MOUNT TYPE	DIMENSION DATA (INCHES)							
	L	W	HF	AL	AD	BT	CD	DW
RD1-WR	3.13	1.75	1.25	2.38	0.34	0.19	5/16-18 UNC X 3/4	1.25
RD2-WR	3.88	2.38	1.75	3.00	0.34	0.22	3/8-16 UNC X 1	1.75
RD3-WR	5.50	3.38	2.88	4.13	0.56	0.25	1/2-13 UNC X 1	2.50
RD4-WR	6.25	4.63	2.75	5.00	0.56	0.38	1/2-13 UNC X 1	3.00

MODEL NUMBER	RATED CAPACITY [LBS]	RATED DEFLECTION [IN]	DURO (± 5)
RD2-Light Blue-WR	35	0.4	30
RD2-Brown-WR	45	0.4	40
RD2-Brick Red-WR	70	0.4	50
RD 2-Lime-WR	120	0.4	60

MODEL NUMBER	RATED CAPACITY [LBS]	RATED DEFLECTION [IN]	DURO (± 5)
RD3-Brown-WR	250	0.5	40
RD3-Brick Red-WR	525	0.5	50
RD3-Lime-WR	750	0.5	60
RD3-Charcoal-WR	1100	0.5	70

MODEL NUMBER	RATED CAPACITY [LBS]	RATED DEFLECTION [IN]	DURO (± 5)
RD2-Light Blue-WR	135	0.5	30
RD2-Brown-WR	170	0.5	40
RD2-Brick Red-WR	240	0.5	50
RD 2-Lime-WR	380	0.5	60
RD2 Charcoal-WR	550	0.5	70

MODEL NUMBER	RATED CAPACITY [LBS]	RATED DEFLECTION [IN]	DURO (± 5)
RD4-Brown-WR	1500	0.5	40
RD4-Brick Red-WR	2250	0.5	50
RD4-Lime-WR	3000	0.5	60
RD4-Charcoal-WR	4000	0.5	70

FIGURE 36 - DURULENE ISOLATOR CROSS-REFERENCE

## INSTALLATION OF DURULENE VIBRATION ISOLATORS

1. Read instructions in their entirety before beginning installation.
2. Isolators are shipped fully assembled and are to be positioned in accordance with the submittal drawings or as otherwise recommended.
3. Set isolators on floor, housekeeping pad, or sub-base, ensuring that all isolator centerlines match the equipment mounting holes. The VMC group recommends that the isolator base ("A") be installed on a level surface. Shim or grout as required, leveling all isolator bases to the same elevation (1/32-inch maximum difference can be tolerated).
4. Bolt or anchor all isolators to supporting structure utilizing base thru holes ("B").
5. Remove top bolt and top washer. Place equipment on top of isolators so that mounting holes in equipment or base line up with threaded hole ("C").
6. Reinstall top bolt and washer and tighten down.
7. Installation is complete.

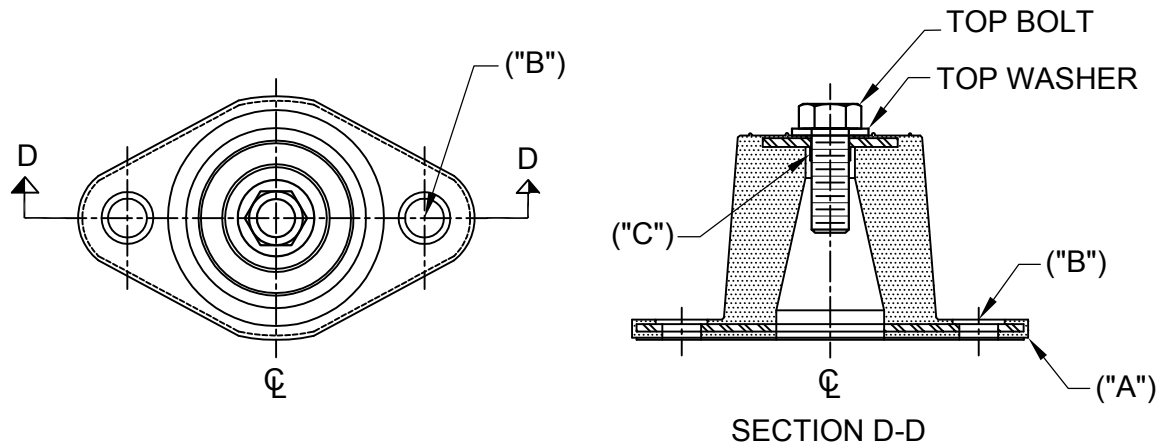

LD13762B

**FIGURE 37 - INSTALLATION OF DURULENE VIBRATION ISOLATORS**

## SECTION 6 – COMMISSIONING

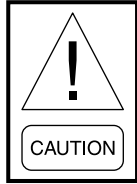

*Commissioning of this unit should only be carried out by Quantech Authorized personnel.*

Commissioning personnel should be thoroughly familiar with the information contained in this literature, in addition to this section.

Commissioning should be performed using the detailed checks outlined in the “Equipment Pre-Startup And Startup Check List” (Page 107).

### PREPARATION – POWER OFF

The following basic checks should be made with the customer power to the unit switched OFF.

### Inspection

Inspect unit for installation damage. If found, take action and/or repair as appropriate.

### Refrigerant Charge

Check that pressure is present in both systems and that no leaks are apparent. If no pressure is present, a leak test must be undertaken, the leak(s) located and repaired. Condensing units are supplied with a nitrogen or refrigerant holding charge (see tag on unit). These systems must be evacuated with a suitable vacuum pump/recovery unit as appropriate to below 500 microns.

Care must also be taken to liquid charge slowly to avoid excessive thermal stress at the charging point. Once the vacuum is broken, charge into the condenser coils with the full operating charge to provide 12° F -15° F subcooling.

### Service and Oil Line Valves

Open each compressor suction, economizer, and discharge service valve. If valves are of the back-seat type, open them fully (counterclockwise) then close one turn of the stem to ensure operating pressure is fed to pressure transducers. Open the liquid line service valve and oil return line ball valve fully in each system.

### Compressor Oil

To add oil to a circuit:

1. Connect a YORK hand oil pump (Part No. 470-10654-000) to the 1/4” oil charging valve with a length of clean hose or copper line, but do not tighten the flare nut.
2. Using clean oil of the correct type (“V” oil), pump oil until all air has been purged from the hose, then tighten the nut.
3. Stroke the oil pump to add oil to the oil system. The oil level should be between the bottom and middle of the sight glass.
4. Check oil levels after operating the system at full load.
5. Turn OFF the system and check the level.

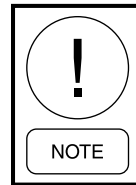

*High oil concentration in the system may cause nuisance trips resulting from incorrect readings on the level sensor and temperature sensors. Temperature sensor errors may result in poor liquid control and resultant liquid overfeed and subsequent damage to the compressor.*

### Fans

Check that all fans are free to rotate and are not damaged. Ensure blades are at the same height when rotated. Ensure fan guards are securely fixed.

### Isolation / Protection

Verify all sources of electrical supply to the unit are taken from a single point of isolation. Check that the maximum recommended fuse sizes given in the Technical Data Section has not been exceeded.

### Control Panel

Check the panel to see that it is free of foreign materials (wire, metal chips, etc.) and clean out if required.

### Power Connections

Check that the customer power cables are connected correctly to the terminal blocks or optional circuit breaker. Ensure that power cable connections, within the panels to the circuit breaker or terminal blocks, are tight.

## Grounding

Verify that the unit's protective ground terminal(s) are properly connected to a suitable grounding point. Ensure that all unit internal ground connections are tight.

## Supply Voltage

Verify that the site voltage supply corresponds to the unit requirement and is within the limits given in the Technical Data Section.

## PREPARATION – POWER ON



*Perform the commissioning using the detailed checks outlined in the “Equipment Pre-Startup and Startup Check List” as the commissioning procedure is carried out.*

Apply power to the unit. Turn ON the option panel circuit breaker if supplied.



*The machine is now live!*

## Switch Settings

Ensure that the condensing unit OFF/ON UNIT switch at the bottom of the keypad is OFF. Place the optional circuit breaker handle on the panel door to ON. The customer's disconnection devices can now be set to ON.

Verify the control panel display is illuminated. Ensure the system switches under the SYSTEM SWITCHES key are in the OFF position.

## Compressor Heaters

Verify the compressor heaters are energized. If the ambient temperature is above 96 °F (36 °C) the compressor heaters must be on for at least 8 hours before start-up to ensure all refrigerant liquid is driven out of the compressor and the oil. If the ambient temperature is below 86 °F (30 °C), allow 24 hours.

## Air Flow Switch

Verify an air flow switch is correctly fitted in the customer's ductwork and wired into the control panel correctly using shielded cable.

The air flow switch should be connected to terminals 13 and 14 of XTBC1 on the panel. (See *Figure 10* on page 37).

**EQUIPMENT PRE-STARTUP AND STARTUP CHECKLIST**

CUSTOMER: \_\_\_\_\_ JOB NAME: \_\_\_\_\_  
 ADDRESS: \_\_\_\_\_ LOCATION: \_\_\_\_\_  
 PHONE: \_\_\_\_\_ CUSTOMER ORDER NO: \_\_\_\_\_  
 JCI TEL NO: \_\_\_\_\_ JCI ORDER NO: \_\_\_\_\_ JCI CONTRACT NO: \_\_\_\_\_

**CHILLER MODEL NO:** \_\_\_\_\_ **UNIT SERIAL NO:** \_\_\_\_\_  
 The work (as checked below) is in process and will be completed by: \_\_\_\_\_ / \_\_\_\_\_ / \_\_\_\_\_  
 Month Day Year

The following work must be completed in accordance with installation instructions:

**A. Pre-Startup**

Checking the System Prior To Initial Start (No Power)

**Unit Checks**

1. Inspect the unit for shipping or installation damage. ....
2. Ensure that all refrigerant piping has been completed and is correctly designed. ....
3. Visually check for refrigerant piping leaks. ....
4. Open suction line ball valve, discharge line ball valve, and liquid line valve for each system. ....
5. The compressor oil level should be maintained so that an oil level is visible or splashing in the sight glass when fully loaded. At shutdown, the oil level should be between the bottom and middle of the oil equalizing sight glass. ....
6. Verify proper CFM of air across evaporator coil. Verify air flow switch operation. ....
7. Check the control panel to ensure it is free of foreign material (wires, metal chips, etc.). ....
8. Visually inspect wiring (power and control). Wiring MUST meet N.E.C. and local codes. ....
9. Check tightness of power wiring inside the power panel on both sides of the motor contactors and overloads. ....
10. Check for proper size fuses in main and control circuits, and verify overload setting corresponds with RLA and FLA values in electrical tables. ....
11. Ensure 120VAC Control Power to TB1 has 15 amp minimum capacity. ....
12. Be certain all temp sensors are installed correctly. ....

13. Verify that TXV bulbs are strapped onto the suction lines at 4 or 8 o'clock positions or suction temperature sensors if EEVs are installed. ....

**B. Compressor Heaters**

(Power on – 24 Hours Prior To Start)

Apply 120VAC and verify its value between terminals 5 and 2 of XTBC2. The voltage should be 120VAC plus or minus 10%. Power must be applied 24 hours prior to start-up. Each heater should draw approximately 0.5-1A. ....

**C. Startup**

**Panel Checks**

(Power On – Both Unit Switch Off)

1. Apply 3-phase power and verify its value. Voltage imbalance should be no more than 2% of the average voltage. ....
2. Apply 120VAC and verify its value on the terminal block in the Power Panel. Make the measurement between terminals 5 and 2 of XTBC2. The voltage should be 120VAC plus or minus 10%. ....
3. Program/verify the cooling setpoints, program setpoints, and unit options. Record the values in Table 11 (see sections on Setpoints and Unit Keys for programming instruction in Table 16 and 17). ....
4. Put the unit into Service Mode (as described under the Control Service and Troubleshooting section) and cycle each condenser fan to ensure proper rotation. ....
5. Prior to this step, turn system 2 OFF (if applicable – refer to Option 2 under "UNIT keys" in section 7 for more information on system switches). Connect a manifold gauge to system 1 suction and discharge service valves. ....

Setpoints Entry List

<b>OPTIONS</b>	
Display Language	
SYS 1 Switch	
Sys 2 Switch	
Chilled Liquid	
* Ambient Control	
Local/Remote Mode	
Control Mode	
Display Units	
* Lead/Lag Control	
* Fan Control	
Manual Override	
Current Feedback	
** Soft Start	
** Unit Type	
** Refrigerant Type	
** Expansion Valve Type	
<b>COOLING SETPOINTS</b>	
Cooling Setpoint	
Range	
EMS-PWM Max. Setpoint	
<b>PROGRAM</b>	
Discharge Pressure Cutout	
Suct. Pressure Cutout	
Low Amb. Temp. Cutout	
Anti-Recycle Time	
Fan Control On Pressure	
Fan Differential Off Pressure	
Total # of Compressors	
* Number of Fans/System	
* Unit/Sys Voltage	
Unit ID	
* Sys 1 Superheat Setpoint	
* Sys 2 Superheat Setpoint	

\*Not on All Models  
\*\*Viewable Only

Place the Unit Switch in the control panel to the "ON" position. As each compressor cycles ON, ensure that the discharge pressure rises and the suction pressure decreases. If this does not occur, the compressor being tested is operating in the reverse direction and must be corrected. After verifying proper compressor rotation, turn the Unit Switch to "OFF."



*The discharge air or suction pressure setpoint may need to be temporarily lowered to ensure all compressors cycle "ON."*

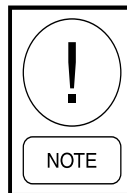

*This unit uses scroll compressors which can only operate in one direction. Failure to observe this will lead to compressor failure.*

- Turn system 1 "off" and system 2 "on" (refer to Option 2 under "UNIT keys" in Section 7 for more information on system switches).

Place the Unit Switch in the control panel to the "ON" position. As each compressor cycles "on", ensure that the discharge pressure rises and the suction pressure decreases. If this does not occur, the compressor being tested is operating in the reverse direction and must be corrected. After verifying proper compressor rotation, turn the Unit Switch to "OFF".

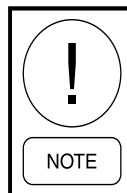

*The chilled liquid setpoint may need to be temporarily lowered to ensure all compressors cycle "ON".*

**D. CHECKING SUPERHEAT AND SUBCOOLING**

The subcooling temperature of each system can be calculated by recording the temperature of the liquid line at the outlet of the condenser and subtracting it from the liquid line saturation temperature at the liquid stop valve (liquid line saturation temp. is converted from a temperature/pressure chart).

Example:

Liquid line pressure =  
 202 PSIG converted to temp. 102°F  
 minus liquid line temp. - 84°F  
 Subcooling = 18°F

The subcooling should be adjusted to 18°F at design conditions.

1. Record the liquid line pressure and its corresponding temperature, liquid line temperature and subcooling below:

	SYS 1	SYS 2	
Liq Line Press =	_____	_____	PSIG
Saturated Temp =	_____	_____	°F
Liq Line Temp =	_____	_____	°F
Subcooling =	_____	_____	°F

After the subcooling is verified, the suction superheat should be checked. The superheat should be checked only after steady state operation of the condensing unit has been established, the leaving water temperature has been pulled down to the required leaving water temperature, and the unit is running in a fully loaded condition. Correct superheat setting for a system is 10°F to 15°F (5.56°C to 8.33°C) 18" (46 cm) from the cooler.

**Superheat should typically be set for no less than 10°F with only a single compressor running on a circuit.** The superheat is calculated as the difference between the actual temperature of the returned refrigerant gas in the suction line entering the compressor and the temperature corresponding to the suction pressure as shown in a standard pressure/temperature chart.

Example:

Suction Temp = 46°F  
 minus Suction Press  
 60 PSIG converted to Temp - 34°F  
 Superheat = 12°F

When adjusting the expansion valve (TXV only), the adjusting screw should be turned not more than one turn at a time, allowing sufficient time (approximately 15 minutes) between adjustments for the system and the thermal expansion valve to respond and stabilize.

Assure that superheat is set at a minimum of 10°F (5.56°C) with a single compressor running on each circuit.

2. Record the suction temperature, suction pressure, suction saturation temperature, and superheat of each system below:

	SYS 1	SYS 2	
Suction Temp =	_____	_____	°F
Suction Pressure =	_____	_____	PSIG
Saturation Temp =	_____	_____	°F
Superheat =	_____	_____	°F

**E. LEAK CHECKING**

Leak check compressors, fittings, and piping to ensure no leaks.

If the unit is functioning satisfactorily during the initial operating period, no safeties trip and the compressors cycle to control water temperature to setpoint, the chiller is ready to be placed into operation.

**Owner's operating personnel:**

Name: \_\_\_\_\_

Phone Number: \_\_\_\_\_

Name: \_\_\_\_\_

Phone Number: \_\_\_\_\_

Name: \_\_\_\_\_

Phone Number: \_\_\_\_\_

THIS PAGE INTENTIONALLY LEFT BLANK



## SECTION 7 – UNIT CONTROLS

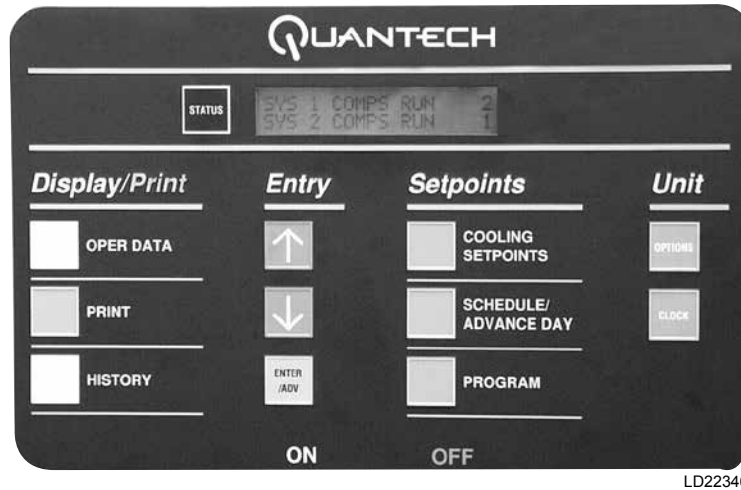

LD22346

### INTRODUCTION

The Quantech Millennium MicroComputer Control Center is a microprocessor based control system designed to provide the entire control for the liquid condensing unit. The control logic embedded in the microprocessor based control system will provide control for the suction pressure or discharge air temperature, as well as sequencing, system safeties, displaying status, and daily schedules. The MicroComputer Control Center consists of four basic components:

1. Microprocessor Board
2. Transformer
3. Display
4. Keypad.

The keypad allows programming and accessing setpoints, pressures, temperatures, cutouts, daily schedule, options, and fault information.

Remote cycling, demand limiting and chilled liquid temperature reset can be accomplished by field supplied contacts.

Compressor starting/stopping and loading/unloading decisions are performed by the Microprocessor to maintain suction pressure or discharge air temperature. These decisions are a function of temperature deviation from setpoint.

A Master ON/Off switch is available to activate or deactivate the unit.

### MICROPROCESSOR BOARD

The Microprocessor Board is the controller and decision maker in the control panel. System inputs such as pressure transducers and temperature sensors are connected directly to the Microprocessor Board. The Microprocessor Board circuitry multiplexes the analog inputs, digitizes them, and scans them to keep a constant watch on the unit operating conditions. From this information, the Microprocessor then issues commands to the Relay Outputs to control contactors, solenoids, etc. for Temperature Control and to react to safety conditions.

Keypad commands are acted upon by the microboard to change setpoints, cutouts, scheduling, operating requirements, and to provide displays.

The on-board power supply converts 24VAC from the 1T transformer to a +12VDC and +5VDC regulated supply located on the Microprocessor Board. This voltage is used to operate integrated circuitry on the board. The 40 character display and unit sensors are supplied power from the microboard 5VDC supply.

24VAC is rectified and filtered to provide unregulated +30VDC to supply the flow switch, PWM remote temperature reset, and demand limit circuitry which is available to be used with field supplied contacts. The Microprocessor Board energizes on-board relays to output 120VAC to motor contactors, solenoid valves, etc. to control system operation. 120VAC is supplied to the optimal T3 Transformer, which supplies 12VAC to the bridge diode module. The Bridge Diode Module rectifies the voltage to -12V unregulated. The +12V unregulated voltage supplies power to the Remote Temperature Reset Circuit Board.

## UNIT SWITCH

A unit ON/OFF switch is just underneath the keypad. This switch allows the operator to turn the entire unit “OFF” if desired. The switch must be placed in the “ON” position for the unit to operate.

## DISPLAY

The 40 Character Display (2 lines of 20 characters) is a liquid crystal display used for displaying system parameters and operator messages.

The display in conjunction with the keypad, allows the operator to display system operating parameters as well as access programmed information already in memory. The display has a lighted background for night viewing and for viewing in direct sunlight.

When a key is pressed, such as the OPER DATA key, system parameters will be displayed and will remain on the display until another key is pressed. The system parameters can be scrolled with the use of the ↑ (UP) and ↓ (DOWN) arrow keys. The display will update all information at a rate of about 1 per second.

Display Messages may show characters indicating “greater than” (>) or “less than” (<). These characters indicate the actual values are greater than or less than the limit values which are being displayed.

## KEYPAD

The 12 button non-tactile keypad allows the user to retrieve vitals system parameters such as system pressures, temperatures, compressor running times and starts, option information on the chiller, and system setpoints. This data is useful for monitoring chiller operation, diagnosing potential problems, troubleshooting, and commissioning the chiller.

It is essential the user become familiar with the use of the keypad and display. This will allow the user to make full use of the capabilities and diagnostic features available.

## BATTERY BACK-UP

The Microprocessor Board contains a Real Time Clock integrated circuit chip with an internal battery backup. The purpose of this battery backup is to assure any programmed values (setpoints, clock, cutouts, etc.) are not lost during a power failure regardless of the time involved in a power cut or shutdown period.

## TRANSFORMER

A 40 VA, 120/24VAC 50/60Hz transformer is provided to supply power to the Microprocessor Board, which in turn rectifies, filters, and regulates as necessary to supply power to the display, sensors, and transducers.

## SINGLE SYSTEM SELECT AND PROGRAMMING # OF COMPRESSORS

The control software is common between single (1) and dual (2) system units. A jumper is installed between terminals 13 and 17 on the user terminal block to configure a unit for a single system. Dual (2) system units do not have a jumper installed. The jumper is only checked by the microboard on power-up.

The total number of compressors is programmable under the PROGRAM key. Single (1) system units can have 2 or 3 compressors. Dual (2) system units can have 4, 5, or 6 compressors.

## STATUS KEY



00066VIP

### Unit Status

Pressing the STATUS key will enable the operator to determine current unit operating status. The messages displayed will include running status, cooling demand, fault status, external cycling device status. The display will be a single message relating to the highest priority message as determined by the microboard. Status messages fall into the categories of General Status and Fault Status.

The following General, Safety, and Warning messages are displayed when the STATUS key is pressed. Following each displayed message is an explanation pertaining to that particular message.

### General Status Messages

In the case of messages which apply to individual systems, SYS 1 and SYS 2 messages will both be displayed and may be different. In the case of single system units, all SYS 2 messages will be blank.

**UNIT SWITCH OFF  
SHUTDOWN**

This message informs the operator that the UNIT switch on the control panel is in the OFF position which will not allow the unit to run.

**REMOTE CONTROLLED  
SHUTDOWN**

The REMOTE CONTROLLED SHUTDOWN message indicates that either an ISN system or RCC has turned the unit “OFF”, not allowing it to run.

**DAILY SCHEDULE  
SHUTDOWN**

The DAILY SCHEDULE SHUTDOWN message indicates that the daily/holiday schedule programmed is keeping the unit from running.

**FLOW SWITCH / REM STOP  
NO RUN PERM**

NO RUN PERM shows that either the flow switch is open or a remote start/stop contact is open in series with the flow switch. A 3-second delay is built into the software to prevent nuisance shutdowns due to erroneous signals on the run permissive input.

**SYS 1 SYS SWITCH OFF  
SYS 2 SYS SWITCH OFF**

SYS SWITCH OFF tells that the system switch under OPTIONS is turned “OFF”. The system will not be allowed to run until the switch is turned back ON.

**SYS 1 NO COOL LOAD  
SYS 2 NO COOL LOAD**

This message informs the operator that the discharge air temperature is below the point (determined by the setpoint and control range) that the microboard will bring on a system or that the microboard has not loaded the lead system far enough into the loading sequence to be ready to bring the lag system “ON”. The lag system will display this message until the loading sequence is ready for the lag system to start.

```

SYS 1 COMPS RUN X
SYS 2 COMPS RUN X

```

The COMPS RUNNING message indicates that the respective system is running due to demand. The “X” will be replaced with the number of compressors in that system that are running.

```

SYS 1 ZONE THERM OFF
SYS 2 ZONE THERM OFF

```

These messages indicate that the zone thermostats for system 1 and system 2 are open. These messages will only be displayed when the control mode is programmed for Suction Pressure

```

SYS 1 AR TIMER XX S
SYS 2 AR TIMER XX S

```

The anti-recycle timer message shows the amount of time left on the respective systems anti-recycle timer. This message is displayed when the system is unable to start due the anti-recycle timer being active.

```

SYS 1 AC TIMER XX S
SYS 2 AC TIMER XX S

```

The anti-coincidence timer is a software feature that guards against two systems starting simultaneously. This assures instantaneous starting current does not become excessively high due to simultaneous starts. The microboard limits the time between compressor starts to 1 minute regardless of demand or the anti-recycle timer being timed out. The anti-coincidence timer is only present on two system units.

```

SYS 1 DSCH LIMITING
SYS 2 DSCH LIMITING

```

When this message appears, discharge pressure limiting is in effect. The Discharge Pressure Limiting feature is integral to the standard software control; however the discharge transducer is optional on some models. Therefore, it is important to keep in mind that this control will not function unless the discharge transducer is installed in the system.

The limiting pressure is a factory set limit to keep the system from faulting on the high discharge pressure cutout due to high load or pull down conditions. When the unload point is reached, the microboard will automatically unload the affected system by de energizing one compressor. The discharge pressure unload will

occur when the discharge pressure gets within 15 PSIG of the programmed discharge pressure cutout. This will only happen if the system is fully loaded and will shut only one compressor off. If the system is not fully loaded, discharge limiting will not go into effect. Reloading the affected system will occur when the discharge pressure drops to 85% of the unload pressure and 10 minutes have elapsed.

```

SYS 1 SUCT LIMITING
SYS 2 SUCT LIMITING

```

When this message appears, suction pressure limiting is in effect. The suction pressure limit is a control point that limits the loading of a system when the suction pressure drops to within 15% above the suction pressure cutout. On a standard system programmed for 80 PSIG/5.52 Bar suction pressure cutout, the microboard would inhibit loading of the affected system with the suction pressure less than or equal to  $1.15 \times 80$  PSIG/5.52 Bar = 92 PSIG/6.34 Bar.

The system will be allowed to load after 60 seconds and after the suction pressure rises above the suction pressure load limit point.

```

SYS 1 LOAD LIMIT XX%
SYS 2 LOAD LIMIT XX%

```

This message indicates that load limiting is in effect and the percentage of the limiting in effect. This limiting could be due to the load limit/pwm input, ISN or RCC controller sending a load limit command.

```

MANUAL
OVERRIDE

```

If MANUAL OVERRIDE mode is selected, the STATUS display will show this message. This will indicate that the Daily Schedule is being ignored and the unit will start-up when chilled liquid temperature allows, Remote Contacts, UNIT switch and SYSTEM switches permitting. This is a priority message and cannot be overridden by anti-recycle messages, fault messages, etc. when in the STATUS display mode. Therefore, do not expect to see any other STATUS messages when in the MANUAL OVERRIDE mode. MANUAL OVERRIDE is only to be used in emergencies or for servicing. Manual override mode automatically disables itself after 30 minutes.

```
SYS 1 PUMPING DOWN
SYS 2 PUMPING DOWN
```

The PUMPING DOWN message indicates that a compressor in the respective system is presently in the process of pumping the system down. When pumpdown is initiated on shutdown, the liquid line solenoid or EEV will close and a compressor will continue to run. When the suction pressure decreases to the suction pressure cutout setpoint or runs for 180 seconds, whichever comes first, the compressor will cycle OFF.

### Fault Safety Status Messages

Safety Status messages appear when safety thresholds in the unit have been exceeded. Safeties are divided into two categories – system safeties and unit safeties. System safeties are faults that cause the individual system to be shut down. Unit safeties are faults that cause all running compressors to be shut down. Following are display messages and explanations.

#### System Safeties

System safeties are faults that cause individual systems to be shut down if a safety threshold is exceeded for 3 seconds. They are auto reset faults in that the system will be allowed to restart automatically after the fault condition is no longer present. However, if 3 faults on the same system occur within 90 minutes, that system will be locked out on the last fault. This condition is then a manual reset. The system switch (under OPTIONS key) must be turned OFF and then back ON to clear the lockout fault. Fault messages will be displayed whenever a system is locked out.

```
SYS 1 HIGH DSCH PRES
SYS 2 HIGH DSCH PRES
```

The Discharge Pressure Cutout is a software cutout in the microprocessor and is backed-up by a mechanical high pressure cutout switch located in the refrigerant circuit. It assures that the system pressure does not exceed safe working limits. The system will shutdown when the programmable cutout is exceeded and will be allowed to restart when the discharge pressure falls 40 PSIG below the cutout. *Discharge transducers must be installed for this function to operate.*

```
SYS 1 LOW SUCT PRESS
SYS 2 LOW SUCT PRESS
```

The Suction Pressure Cutout is a software cutout that helps protect the unit from a coil freeze-up or compressor damage should the system attempt to run with a low refrigerant charge or a restriction in the refrigerant circuit.

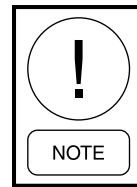

***Repeated starts after resetting a low suction pressure fault will cause coil freeze-up and compressor failure. Whenever a system locks out on this safety, immediate steps should be taken to identify the cause.***

At system start, the cutout is set to 10% of programmed value. During the next 3 minutes the cutout point is ramped up to the programmed cutout point. If at any time during these 3 minutes the suction pressure falls below the ramped cutout point, the system will stop. This cutout is completely ignored for the first 30 seconds of system run time to avoid nuisance shutdowns, especially on units that utilize a low pressure switch in place of the suction pressure transducer.

After the first 3 minutes, if the suction pressure falls below the programmed cutout setting, a “transient protection routine” is activated. This sets the cutout at 10% of the programmed value and ramps up the cutout over the next 30 seconds. If at any time during these 30 seconds the suction pressure falls below the ramped cutout, the system will stop.

```
SYS 1 MP / HPCO FAULT
SYS 2 MP / HPCO FAULT
```

7

```
SYS 1 MP / HPCO INHIB
SYS 2 MP / HPCO INHIB
```

The Motor Protector/Mechanical High Pressure Cutout protects the compressor motor from overheating or the system from experiencing dangerously high discharge pressure.

This fault condition is present when CR1 (SYS 1) or CR2 (SYS 2) relays de-energize due to the HP switch or motor protector opening. This causes the respective CR contacts to open causing 0VDC to be read on the inputs to the microboard. The fault condition is cleared when a 30VDC signal is restored to the input.

The internal motor protector opens at 185°F to 248°F (85°C to 120°C) and auto resets. The mechanical HP switch opens at 585 PSIG plus or minus 10 PSIG (27.92 barg plus or minus .69 barg) and closes at 330 PSIG plus or minus 25 PSIG (22.75 barg plus or minus 1.72 barg).

The compressor is also equipped with a discharge temperature sensor for the purpose of sensing internal scroll temperature. This sensor protects the scrolls from overheating due to inadequate cooling that may occur when refrigerant charge is low, or superheat is too high.

When the sensor senses a high temperature, it opens the motor protector circuit in the compressor causing the compressor to shut down.

During the first two faults an MP/HP INHIBIT message will be displayed and the system will not be locked out. Only after the third fault in 90 minutes will the MP/HPCO FAULT message be displayed.

Whenever the motor protector or discharge sensor shuts down a compressor and the system, the internal compressor contacts will open for a period of 30 minutes to assure that the motor or scroll temperatures have time to dissipate the heat and cool down.

After 30 minutes, the contacts will close and the system will be permitted to restart. The microboard will not try to restart the compressors in a system that shuts down on this safety for a period of 30 minutes to allow the internal compressor to time out.

During the 30 minute timeout, the MP/HPCO INHIB message will be displayed. The MP/HPCO fault will only be displayed after 3 shutdowns in 90 minutes, indicating the system is locked out and will not restart.

**S Y S 1 H I G H M T R C U R R**  
**S Y S 2 H I G H M T R C U R R**

When the System Current Feedback option is installed and selected (Option 11 under OPTIONS key Current Feedback), this safety will operate as follows. If the actual feedback voltage of the system proportional to currents exceeds the programmed trip voltage for 5 seconds, the system will shutdown.

### Unit Safeties

Unit safeties are faults that cause all running compressors to be shut down. Unit faults are auto reset faults in that the unit will be allowed to restart automatically after the fault condition is no longer present.

**U N I T F A U L T :**  
**L O W A M B I E N T T E M P**

The Low Ambient Temp Cutout is a safety shutdown designed to protect the unit from operating in a low ambient condition. If the outdoor ambient temperature falls below the programmable cutout, the unit will shut down. Restart can occur when temperature rises 2°F above the cutoff.

**U N I T F A U L T :**  
**1 1 5 V A C U N D E R V O L T A G E**

The Under Voltage Safety assures that the system is not operated at voltages where malfunction of the microprocessor could result in system damage. When the 115VAC to the micro panel drops below a certain level, a unit fault is initiated to safely shut down the unit. Restart is allowed after the unit is fully powered again and the anti-recycle timers have finished counting down.

**U N I T F A U L T :**  
**H I G H M T R C U R R**

When the CURRENT FEEDBACK ONE PER UNIT option is selected under the OPTIONS key, the unit will shut down when the voltage exceeds the programmed trip voltage for 5 seconds.

The trip voltage is programmed at the factory according to compressor or unit RLA.

Restart will occur after the anti-recycle timer times out.

### Unit Warning

The following messages are not unit safeties and will not be logged to the history buffer. They are *unit warnings* and will not auto-restart. Operator intervention is required to allow a restart of the unit.

**!! LOW BATTERY !!  
CHECK PROG / SETP / OPTN**

The Low Battery Warning can only occur at unit power-up. On micro panel power-up, the RTC battery is checked. If a low battery is found, all programmed setpoints, program values, options, time, schedule, and history buffers will be lost. These values will all be reset to their default values which may not be the desired operating values. Once a faulty battery is detected, the unit will be prevented from running until the PROGRAM key is pressed. Once PROGRAM is pressed the anti-recycle timers will be set to the programmed anti-recycle time to allow the operator time to check setpoints, and if necessary, reprogram programmable values and options.

If a low battery is detected, it should be replaced as soon as possible. The programmed values will all be lost and the unit will be prevented from running on the next power interruption. The RTC/battery (031-02565-000) is located at U5 on the IPU microboard (031-02630-000).

**INCORRECT  
UNIT TYPE**

This indicates the condensing unit jumper is not installed between J11-7 and J11-12, on the I/O Board. This jumper must be installed to operate the condensing unit.

## STATUS KEY MESSAGES

**TABLE 9 - STATUS KEY MESSAGES QUICK REFERENCE LIST**

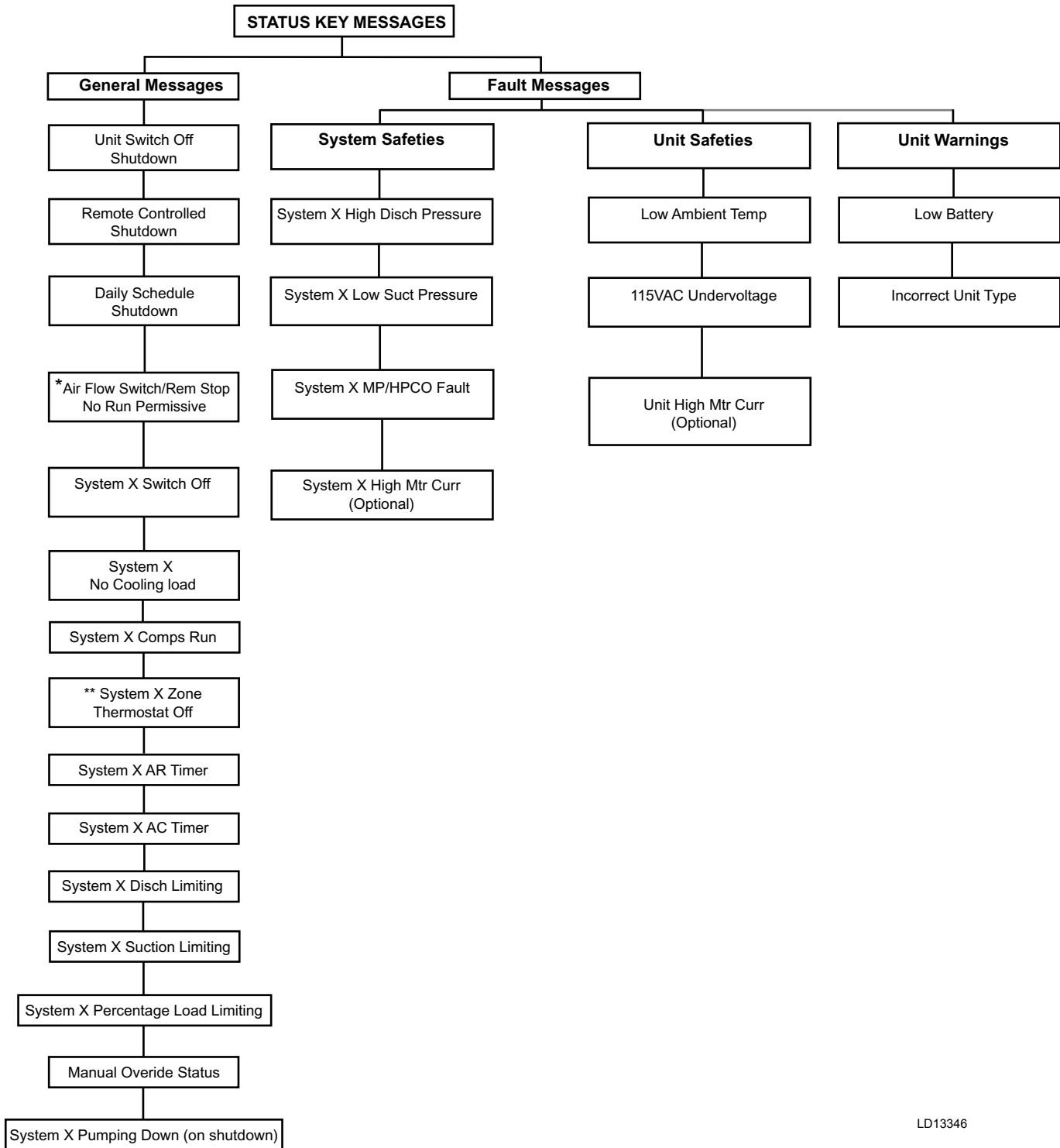

LD13346

\* Only displayed when unit control mode programmed for Discharge Air Temperature.

\*\* Only displayed when unit control mode programmed for Suction Pressure.



## DISPLAY/PRINT KEYS

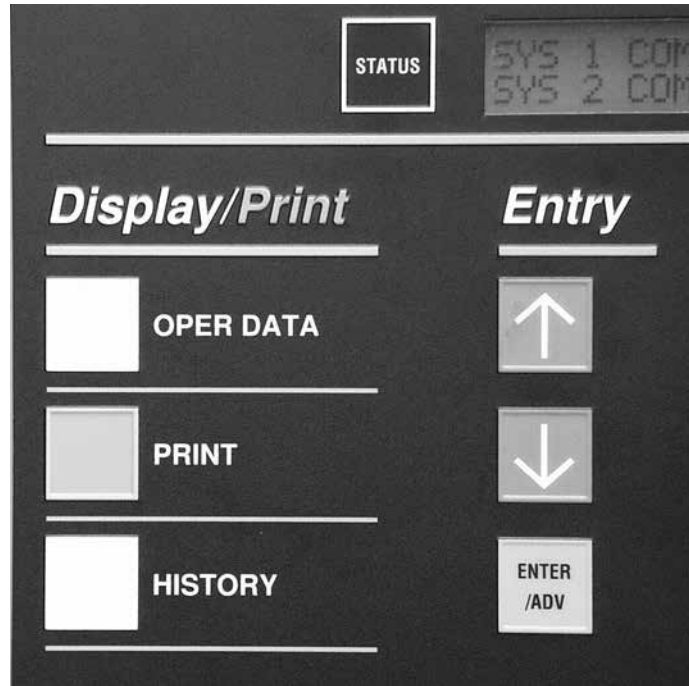

00067VIP

The DISPLAY/PRINT keys allow the user to retrieve system and unit information that is useful for monitoring unit operation, diagnosing potential problems, troubleshooting, and commissioning the unit.

System and unit information, unit options, setpoints, and scheduling can also be printed out with the use of a printer. Both real-time and history information are available.

### Oper Data Key

The OPER DATA key gives the user access to unit and system operating parameters. When the OPER DATA key is pressed, system parameters will be displayed and remain on the display until another key is pressed. After pressing the OPER DATA key, the various operating data screens can be scrolled through by using the ↑ (UP) and ↓ (DOWN) arrow keys or the ENTER/ADV key located under the “ENTRY” section.

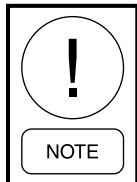

*System 2 information will only be displayed for 2 system units.*

With the “UNIT TYPE” set as a condensing unit (via jumper between J11-7 and J11-12 on the I/O Board), the following list of operating data screens are view-

able under the OPER DATA key in the order that they are displayed. The ↓ (DOWN) arrow key scrolls through the displays in the order they appear below:

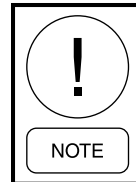

*The unit MUST be set to be a condensing unit via jumper between J11-7 and J11-12 on the I/O Board. DO NOT operate the unit if not properly set up.*



This display shows the discharge air temperature leaving the evaporator. The display will only be shown when the Control Mode is programmed for Discharge Air (under the OPTIONS key). The minimum limit on the display for these parameters are 9.2°F (-12.7°C). The maximum limit on the display is 85.4°F (29.7°C).



This display shows the ambient air temperature. The minimum limit on the display is 0.4°F (-17.6°C). The maximum limit on the display is 131.2°F (55.1°C).

```
S Y S X S P = 1 1 5 . 1 P S I G
      D P = 3 0 5 . 0 P S I G
```

These displays show suction and discharge pressures for each system. The discharge pressure transducer is optional on some models.

If the optional discharge transducer is not installed, the discharge pressure would display 0 PSIG (0 barg).

Some models come factory wired with a low pressure switch in place of the suction transducer. In this case, the suction pressure would only be displayed as the maximum suction pressure reading of greater than 400 PSIG (27.6 barg) when closed, or less than 0 PSIG (0 barg) when open.

The minimum limits for the display are:  
Suction Pressure: 0 PSIG (0 barg)  
Discharge Pressure: 0 PSIG (0 barg)

The maximum limits for the display are:  
Suction Pressure: 400 PSIG (27.6 barg)  
Discharge Pressure: 650 PSIG (44.8 barg)

```
S Y S X H O U R S 1 = X X X X X
      2 = X X X X X, 3 = X X X X X
```

```
S Y S X S T A R T S 1 = X X X X X
      2 = X X X X X, 3 = X X X X X
```

The above two messages will appear sequentially for each system. The first display shows accumulated running hours of each compressor for the specific system. The second message shows the number of starts for each compressor on each system.

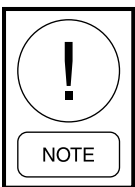

***Run times and starts will only be displayed for the actual number of systems and compressors on the unit.***

A total of 99,999 hours and starts can be logged before the counter rolls over to “0”.

```
LOAD TIMER 5 8 SEC
UNLOAD TIMER 0 SEC
```

This display of the load and unload timers indicate the time in seconds until the unit can load or unload. Whether the systems loads or unloads is determined by how far the actual liquid temperature is from setpoint. A detailed description of unit loading and unloading is covered under the topic of Capacity Control.

```
LEAD SYSTEM IS
SYSTEM NUMBER 2
```

This display indicates the current LEAD system. In this example system 2 is the LEAD system, making system 1 the LAG system. The LEAD system can be manually selected or automatic. *Refer to the programming under the OPTIONS key.* The Lead System display will only appear on a two system unit.

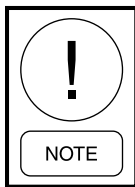

***A unit utilizing hot gas bypass should be programmed for MANUAL with system 1 as the lead system. Failure to do so will prevent hot gas operation if system 2 switches to the lead system when programmed for AUTOMATIC LEAD/LAG.***

```
EVAP PUMP IS ON
EVAP HEATER IS OFF
```

This display is for chiller applications only and does not apply to condensing units. However, the evaporator contacts could be used to control the air handler.

The evaporator pump dry contacts are energized (closed) when any compressor is running, or the unit is not OFF on the daily schedule and the unit switch is ON. However, even if one of above is true, the contacts will not close if the micro panel has been powered up for less than 30 seconds or if the contacts have been closed in the last 30 seconds.

**ACTIVE REMOTE CTRL  
 NONE**

There are several types of remote systems that can be used to control or monitor the unit. The following messages indicate the type of remote control mode active:

NONE – no remote control active. Remote monitoring may be via ISN.

ISN – YORK Talk via ISN allows remote load limiting and temperature reset through an ISN system.

\*LOAD LIM – load limiting enabled. Can be either stage 1 or stage 2 of limiting.

\*PWM TEMP – EMS-PWM temperature reset

*\*Refer to the section on OPERATING CONTROLS.*

If the microboard is programmed for CURRENT FEEDBACK ONE PER UNIT under the OPTIONS key, the display will show up as the first display prior to the SYS 1 displays. Total unit current is displayed as shown below:

**UNIT AMPS = 54.0  
 VOLTS = 1.2**

If the microboard is programmed for CURRENT FEEDBACK NONE, no current display will appear.

**SYS X COMP STATUS  
 1 = XXX 2 = XXX 3 = XXX**

**SYS X RUN TIME  
 XX - XX - XX - XX D - H - M - S**

**SYS X LLSV IS ON  
 HOT GAS SOL IS OFF**

**SYS X FAN STAGE 3**

**SYS X AMPS = 36.0  
 VOLTS = 0.8**

The preceding five messages will appear sequentially, first for system 1, then for system 2.

The first message indicates the system and the associated compressors which are running.

The second message indicates the system run time in days – hours – minutes – seconds. Please note that this is not accumulated run time but pertains only to the current system cycle.

The third message indicates the system, and whether the liquid line solenoid or EEV pilot solenoid and hot gas solenoid are being turned ON by the microboard. Please note that hot gas is not available for system 2, so there is no message pertaining to the hot gas solenoid when system 2 message is displayed.

The fourth message indicates which stage of condenser fan operation is active.

*See the section on Condenser Fan Control in the UNIT OPERATION section for more information.*

The fifth message displays current as sensed by the optional current feedback circuitry. The display reads out in amps along with the DC feedback voltage from the module. Current is calculated by:

$$\frac{225A \times \text{Actual Volts}}{5 \text{ Volts}}$$

Individual displays will be present for each system, if CURRENT FEEDBACK ONE PER SYSTEM is programmed under the OPTIONS key. Combined compressor current for each system is displayed.

**Oper Data Quick Reference List**

The following table is a quick reference list for information available under the OPER DATA key.

**TABLE 10 - OPERATION DATA**

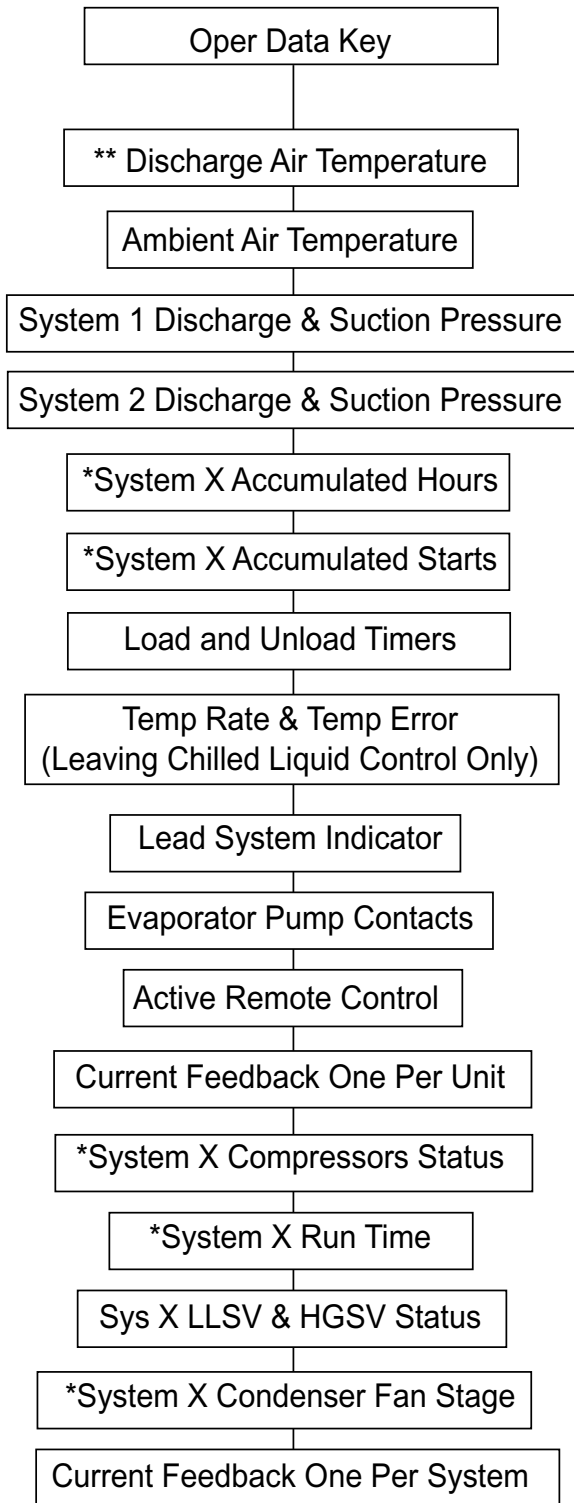

LD13347

\* Block of information repeats for each system

\*\* Only displayed when Control Mode is programmed for Discharge Air Temperature Control.

**Print Key**

The PRINT key allows the operator to obtain a printout of real-time system operating data or a history printout of system data at the “instant of the fault” on the last six faults which occurred on the unit. An optional printer is required for the printout.

**Operating Data Printout**

Pressing the PRINT key and then OPER DATA key allows the operator to obtain a printout of current system operating parameters. When the OPER DATA key is pressed, a snapshot will be taken of system operating conditions and panel programming selections. This data will be temporarily stored in memory and transmission of this data will begin to the printer. A sample Operating Data printout is shown below. (Note: Not all values are printed for all models.)

```

MILLENNIUM CONDENSING UNIT

UNIT STATUS
2:04PM 01 JULY 09

SYS 1          NO COOLING LOAD
SYS 2          COMPRESSORS RUNNING 2

OPTIONS
AMBIENT CONTROL          STANDARD
LOCAL/REMOTE MODE       REMOTE
CONTROL MODE             LEAVING LIQUID
LEAD/LAG CONTROL        AUTOMATIC
FAN CONTROL              AMB & DSCH PRESS
CURRENT FEEDBACK        NONE
SOFT START              ENABLED
EXPANSION VALVE         THERMOSTATIC

PROGRAM VALUES
DSCH PRESS CUTOUT       395 PSIG
SUCTION PRESS CUTOUT    44 PSIG
LOW AMBIENT CUTOUT      25.0 DEG F
ANTI RECYCLE TIME       600 SECS
FAN CONTROL ON PRESS    240 PSIG
FAN DIFF OFF PRESS      80 PSIG
NUMBER OF COMPRESSORS   6
NUMBER OF FANS PER SYSTEM 4
UNIT TRIP VOLTS         3.0
REFRIGERANT TYPE        R-410A
REMOTE UNIT ID PROGRAMMED 1

UNIT DATA
DISCHARGE AIR TEMP      67.0 DEG F
COOLING RANGE           65.0 +/- 5.0 DEG F
AMBIENT AIR TEMP        74.8 DEG F
LEAD SYSTEM             SYS 2
EVAPORATOR PUMP         ON
EVAPORATOR HEATER       OFF
ACTIVE REMOTE CONTROL    NONE
UNIT XXX.X AMPS         X.X VOLTS
SOFTWARE VERSION        C.M08.14.02
    
```

```

        SYSTEM 1 DATA
    COMP STATUS  1=OFF 2=OFF 3=OFF
    RUN TIME    0- 0- 0- 0 D-H-M-S
    SUCTION PRESSURE      66 PSIG
    DISCHARGE PRESSURE   219 PSIG
    SUCTION TEMPERATURE  52.8 DEGF
    LIQUID LINE SOLENOID      OFF
    HOT GAS BYPASS VALVE     OFF
    CONDENSER FAN STAGES     OFF
    SYSTEM          XXX.X AMPS X.X VOLTS

        SYSTEM 2 DATA
    COMP STATUS 1=OFF, 2=OFF, 3=OFF
    RUN TIME    0- 0- 0- 0 D-H-M-S
    SUCTION PRESSURE      51 PSIG
    DISCHARGE PRESSURE   157 PSIG
    SUCTION TEMPERATURE  44.3 DEGF
    LIQUID LINE SOLENOID      ON
    CONDENSER FAN STAGE     3
    SYSTEM          XXX.X AMPS X.X VOLTS

        DAILY SCHEDULE
    S M T W T F S      *=HOLIDAY
    MON START=00:00AM
    STOP=00:00AM
    TUE START=00:00AM
    STOP=00:00AM
    WED START=00:00AM
    STOP=00:00AM
    THU START=00:00AM
    STOP=00:00AM
    FRI START=00:00AM
    STOP=00:00AM
    SAT START=00:00AM
    STOP=00:00AM
    HOL START=00:00AM
    STOP=00:00AM
    
```

### History Printout

Pressing the PRINT key and then the HISTORY key allows the operator to obtain a printout of information relating to the last 6 Safety Shutdowns which occurred. The information is stored at the instant of the fault, regardless of whether the fault caused a lockout to occur. The information is also not affected by power failures (long-term internal memory battery backup is built into the circuit board) or manual resetting of a fault lockout.

When the HISTORY key is pressed, a printout is transmitted of all system operating conditions which were stored at the “instant the fault occurred” for each of the 6 Safety Shutdowns buffers. The printout will begin with the most recent fault which occurred. The most recent fault will always be stored as Safety Shutdown No. 1. Identically formatted fault information will then be printed for the remaining safety shutdowns.

Information contained in the Safety Shutdown buffers is very important when attempting to troubleshoot a system problem. This data reflects the system conditions at the instant the fault occurred and often reveals other system conditions which actually caused the safety threshold to be exceeded.

The history printout is similar to the operational data printout shown in the previous section. The differences are in the header and the schedule information. The daily schedule is not printed in a history print.

One example history buffer printout is shown following. The data part of the printout will be exactly the same as the operational data print so it is not repeated here. The difference is that the Daily Schedule is not printed in the history print and the header will be as follows.

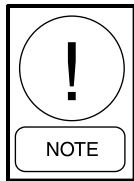

**See Service And Troubleshooting section for Printer Installation information.**

```

MILLENNIUM CONDENSING UNIT

SAFETY SHUTDOWN NUMBER 1
SHUTDOWN @ 3:56PM 29 JULY 09

SYS 1  HIGH DSCH PRESS SHUTDOWN
SYS 2                                NO FAULTS
    
```

## History Displays

The HISTORY key gives the user access to many unit and system operating parameters at the time of a unit or system safety shutdown. When the HISTORY key is pressed the following message is displayed.

```
DISPLAY SAFETY SHUT-
DOWN NO. 1 (1 TO 6)
```

While this message is displayed, the ↑ (UP) arrow key can be used to select any of the six history buffers. Buffer number 1 is the most recent, and buffer number 6 is the oldest safety shutdown that was saved.

After selecting the shutdown number, pressing the ENTER key displays the following message which shows when the shutdown occurred.

```
SHUTDOWN OCCURRED
03:56 PM 29 JAN 02
```

Pressing the ↓ (DOWN) arrow key repeatedly from the DISPLAY SAFETY SHUTDOWN NO. X displays the software version.

```
SOFTWARE VERSION
C.M08.14.02
```

The ↑ (UP) and ↓ (DOWN) arrow keys are used to scroll forward and backward through the history buffer to display the shutdown conditions stored at the instant the fault occurred. The ↓ (DOWN) arrow key scrolls through the displays in the order they appear below:

```
UNIT FAULT :
LOW SUCT PRESS
```

Displays the type of fault that occurred.

```
UNIT TYPE
CONDENSING UNIT
```

Displays the type of unit; Liquid, Condensing Unit or Heat Pump.

```
AMBIENT CONTROL
XXXXXXXXXX
```

Displays the type of Ambient Control; Standard or Low Ambient.

```
LOCAL / REMOTE MODE
XXXXXXXXXX
```

Displays Local or Remote control selection.

```
CONTROL MODE
SUCTION PRESSURE
```

Displays the type of DSCH Air Temp Control (OAT or Suct Press).

```
LEAD / LAG CONTROL
XXXXXXXXXX
```

Displays the type of lead/lag control; Manual System 1, Manual System 2 or Automatic. This is only selectable on 2-system units.

```
FAN CONTROL
DISCHARGE PRESSURE
```

Displays the type of fan control; Discharge Pressure or Ambient and Discharge Pressure.

```
MANUAL OVERRIDE MODE
XXXXXXXXXX
```

Displays whether Manual Override was Enabled or Disabled.

```
CURRENT FEEDBACK
XXXXXXXXXXXXXXXXXX
```

Displays type of Current Feedback utilized.

```
SOFT START
XXXXXX
```

Displays whether the optional European Soft Start was installed and selected.

```
DISCHARGE PRESSURE
CUTOUT = XXXX PSIG
```

Displays the programmed Discharge Pressure Cutout.

```
SUCTION PRESSURE
CUTOUT = XXXX PSIG
```

Displays the programmed Suction Pressure Cutout.

```
LOW AMBIENT TEMP  
CUTOUT = XXX.X °F
```

Displays the programmed Low Ambient Cutout.

```
FAN CONTROL ON  
PRESSURE = XXX PSIG
```

Displays the programmed Fan On Pressure.

```
FAN DIFFERENTIAL OFF  
PRESSURE = PSIG
```

Displays the programmed Fan Off Differential.

```
SYS 1 TRIP VOLTS  
= X.X VOLTS
```

Displays the programmed High Current Trip Voltage.

```
SYS 2 TRIP VOLTS  
= X.X VOLTS
```

Displays the programmed High Current Trip Voltage.

```
DISCHARGE AIR TEMP  
= XXX.X °F
```

Displays the Discharge Air Temp if Discharge Air Temp Control is selected.

```
SETPOINT = XXX.X °F  
RANGE = +/- °F
```

Displays the programmed Setpoint and Range, if the unit is programmed for DAT Control Mode.

```
SETPOINT = XXX.X °F  
RANGE = +XX.X °F
```

Displays the programmed Setpoint and Range, if the unit is programmed for Discharge Air Control.

```
SYS 1 SP = XXXX PSIG  
RANGE = +/- XXX PSIG
```

```
SYS 2 SP = XXXX PSIG  
RANGE = +/- XXX PSIG
```

Displays the SP Setpoint and Control Range if SP Control is selected.

```
AMBIENT AIR TEMP  
= XXX.X °F
```

Displays the Ambient Temp. at the time of the fault.

```
LEAD SYSTEM IS  
SYSTEM NUMBER X
```

Displays which system is in the lead at the time of the fault.

```
EVAP PUMP IS XXX  
EVAP HEATER IS XXX
```

Displays status of the Evaporator Pump and Heater (not installed on a Quantech) at the time of the fault.

```
ACTIVE REMOTE CTRL  
XXXX
```

Displays whether Remote Control was active when the fault occurred.

```
UNIT ACTUAL AMPS  
= XXX.X AMPS
```

This is only displayed when the Current Feedback option is one per unit.

```
SYS X COMP STATUS  
1 = XXX 2 = XXX 3 = XXX
```

Displays which Compressors were running in the system when the fault occurred.

```
SYS X RUN TIME  
XX-XX-XX-XX D-H-M-S
```

Displays the system run time when the fault occurred.

```
SYS X SP = XXXX PSIG
DP = XXXX PSIG
```

Displays the system Suction and Discharge Pressure of the time of the fault.

```
SYS X SUCT = XXX.X °F
SAT SUCT = XXX.X °F
```

Displays the System Suction Temp and Saturated Suction Temp when an EEV is installed.

```
SYS X LLSV IS XXX
HOT GAS SOL IS XXX
```

Displays whether the System Liquid Line Solenoid or Hot Gas Solenoid was energized at the time of the fault.

```
SYS X FAN STAGE XXX
```

Displays the number of Fan Stages in the system active at the time of the fault.

```
SYS X ACTUAL AMPS
= XXX.X AMPS
```

Displays the system Amperage (calculated approximately) at the time of the fault.

For this message to appear, CURRENT FEEDBACK ONE PER SYSTEM must be programmed under the OPTIONS key. If the microboard is programmed as one CURRENT FEEDBACK ONE PER UNIT under the PROGRAM key, the display will be the first display prior to the SYS 1 info. If the microboard is programmed for CURRENT FEEDBACK NONE, no current display will appear.

Displays for System 1 starting with SYS X NUMBER OF COMPS RUNNING X through SYS X AMPS = XXX.X VOLTS = X.X will be displayed first, followed by displays for System 2.

Further explanation of the above displays is covered under the STATUS, OPER DATA, COOLING SETPOINTS, PROGRAM, and OPTIONS keys.

### Software Version

The software version may be viewed by first pressing the HISTORY key and then the ↓ (DOWN) arrow key.

After pressing the HISTORY key, the display safety shutdown message will be displayed.

```
DISPLAY SAFETY SHUT -
DOWN NO. 1 (1 TO 6)
```

After the ↓ (DOWN) arrow key is pressed, the software version will appear.

```
SOFTWARE VERSION
C.M08.14.02
```



## ENTRY KEYS

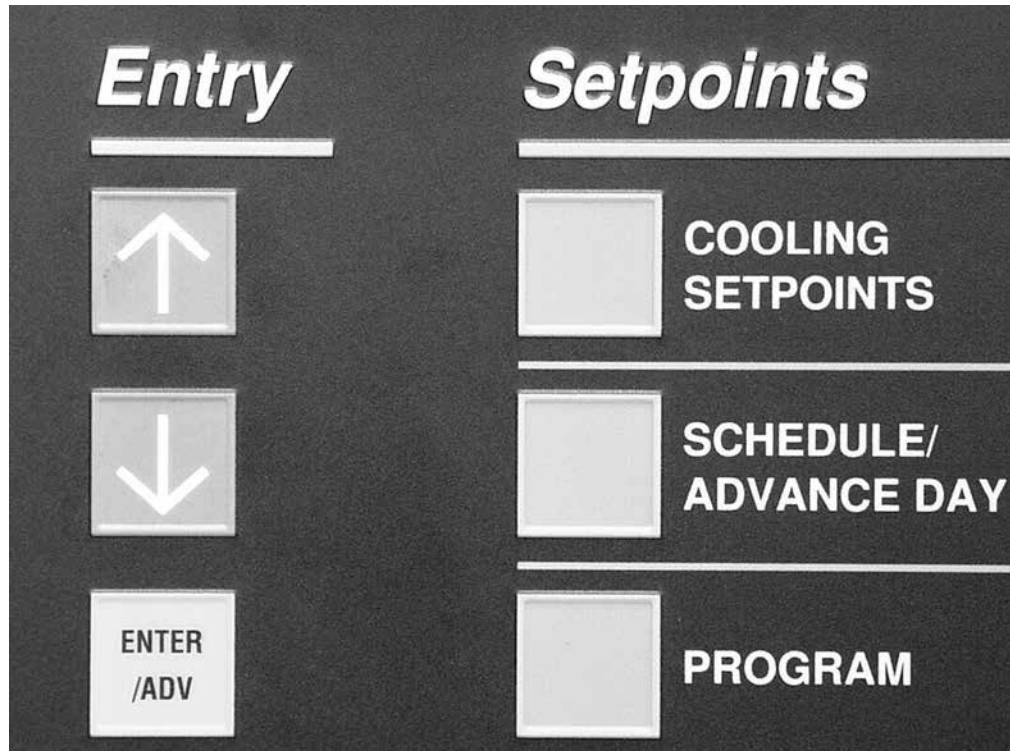

00068VIP

7

The ENTRY keys allows the user to view, change programmed values. The ENTRY keys consist of an ↑ (UP) arrow key, ↓ (DOWN) arrow key, and an ENTER/ADV key.

### Up and Down Arrow Keys

Used in conjunction with the OPER DATA, HISTORY, COOLING SETPOINTS, SCHEDULE/ADVANCE DAY, OPTIONS and CLOCK keys, the ↑ (UP) and ↓ (DOWN) arrow keys allow the user to scroll through the various data screens. Refer to the section on “Display/Print” keys for specific information on the displayed information and specific use of the ↑ (UP) and ↓ (DOWN) arrow keys.

The ↑ (UP) arrow key and ↓ (DOWN) arrow key are also used for programming the control panel such as changing numerical or text values when programming cooling setpoints, setting the daily schedule, changing safety setpoints, unit options, and setting the clock.

### Enter/Adv Key

The ENTER/ADV key must be pushed after any change is made to the cooling setpoints, daily schedule, safety setpoints, chiller options, and the clock. Pressing this key “enters” the new values into memory. If the ENTER/ADV key is not pressed after a value is changed, the changes will not be “entered” and the original values will be used to control the chiller.

Programming and a description on the use of the ↑ (UP) arrow key, and ↓ (DOWN) arrow, and ENTER/ADV keys are covered in detail under the SETPOINTS, and UNIT keys.

## SETPOINTS KEYS

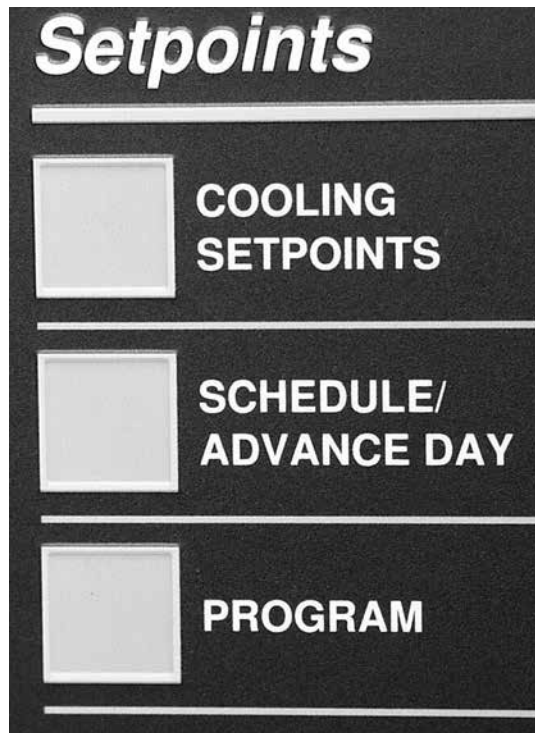

00069VIP

Programming of the cooling setpoints, daily schedule, and safeties is accomplished by using the keys located under the SETPOINTS section.

The three keys involved are labeled COOLING SETPOINTS, SCHEDULE/ADVANCE DAY, and PROGRAM.

The following are instructions for programming the respective setpoints. The same instruction should be used to view the setpoints with the exception that the setpoint will not be changed.

### Cooling Setpoints

The Cooling setpoint and Range can be programmed by pressing the COOLING SETPOINTS key. After pressing the COOLING SETPOINTS key, the Cooling Mode (Discharge Air Temperature or Suction Pressure Control) will be displayed for a few seconds, and then the setpoint entry screen will be displayed.

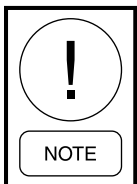

*Unit must first be checked for "Unit Type - Condensing Unit" under the OPTION key to allow programming of appropriate setpoints. This is accomplished by the jumper between J11-7 and J11-12 on the I/O Board.*

The following are the four possible messages that can be displayed after pressing the COOLING SETPOINT key, indicating the cooling mode:

LOCAL DISCHARGE  
AIR TEMP CONTROL

This message indicates that the cooling setpoint is under LOCAL control. That is, the cooling setpoint is controlling to the *locally* programmed setpoint. The message also indicates that the control point is based on Discharge Air temperature leaving the evaporator coil.

LOCAL SUCTION  
PRESSURE CONTROL

This message indicates that the cooling setpoint is under LOCAL control (the cooling setpoint is controlling to the *locally* programmed cooling setpoint). However, unlike the previous message, it is now indicating that the control point is based on Suction Pressure.

REMOTE DISCHARGE  
AIR TEMP CONTROL

This message indicates that the cooling setpoint is under REMOTE control. When under remote control, the cooling setpoint will be determined by a remote device such as an ISN control. The message also indicates that the control point is based on Discharge Air Temperature leaving the evaporator.

**REMOTE SUCTION  
 PRESSURE CONTROL**

This message indicates that the cooling setpoint is under REMOTE control. When under remote control, the cooling setpoint will be determined by a remote device such as an ISN control. This message also indicates that the control point is based on Suction Pressure.

Immediately after the control mode message is displayed, the COOLING SETPOINT entry screen will be displayed. If the unit is programmed for Discharge Air Temperature the following message will be displayed:

**SETPOINT = 55.0 °F  
 RANGE = +/- 5.0 °F**

(Discharge Air Temperature control)

The above message shows the current Discharge Air temperature SETPOINT at 55.0°F (notice the cursor positioned under the number 5). Pressing either the UP or DOWN arrow will change the setpoint in .5°F increments. After using the UP and DOWN arrows to adjust to the desired setpoint, the ENTER/ADV key must be pressed to enter this number into memory and advance to the RANGE SETPOINT.

This will be indicated by the cursor moving under the RANGE setpoint. The ↑ (UP) and ↓ (DOWN) arrow keys are used to set the RANGE, in .5 °F increments, to the desired RANGE setpoint. After adjusting the setpoint, the ENTER/ADV key must be pressed to enter the data into memory.

The Discharge Air temperature SETPOINT is programmed from 45°F (7.2°C) to 70°F (21.1°C). The Control Range is programmed from 3.0°F (-16.1°C) to 10°F (-12.0°C).

If the unit was programmed for Suction Pressure control, the following message would be displayed instead of the previous message.

**SYS X SP = 105 PSIG  
 RANGE = +/- 3 PSIG**

(Suction Pressure control)

The setpoint and range are programmed with the ↑ (UP) and ↓ (DOWN) arrow, and ENTER/ADV key as described in the previous setpoint message. The setpoints in Suction Pressure Control are the suction pressures of each individual system on the condensing Unit and will control to within plus or minus the cooling range.

On two system units, each system is controlled independently of each other according to its own setpoint and cooling range, so there will be two similar displays; a setpoint and range for both system 1 and system 2.

The Suction Pressure SETPOINTS are programmable from 60 PSIG to 90 PSIG. The Control Range is programmable from 2 PSIG to 10 PSIG.

Both Discharge Air Temperature and Suction Pressure control are described in detail under the section on Capacity Control.

Pressing the COOLING SETPOINTS again, after setting the “local” setpoint(s), will display the remote setpoint and cooling range. This display automatically updates about every 2 seconds. Notice that these setpoints are not “locally” programmable, but are controlled by a remote device such as an ISN control. These setpoints would only be valid if the unit was operating in the REMOTE mode. The following messages illustrate both Discharge Air Temperature and Suction Pressure control respectively.

**REM SETP = 55.0 °F  
 RANGE = +/- 5.0 °F**

(Discharge Air Temperature control)

**REM SP X = 105 PSIG  
 RANGE = +/- 3 PSIG**

(Suction Pressure control)

Pressing the COOLING SETPOINTS again will bring up the display that allows the Maximum EMS-PWM Temperature Reset to be programmed. This message is shown below.

**MAX EMS - PWM REMOTE  
 TEMP RESET = +20 °F**

The Temp Reset value is the maximum allowable reset of the Discharge Air Temperature Setpoint. The setpoint can be reset upwards by the use of a contact closure on the PWM Temp Reset input (XTBC1 terminals 13 - 20). *See the section on Operating Controls for a detailed explanation of this feature.*

As with the other setpoints, the ↑ (UP) Arrow and ↓ (DOWN) arrow keys are used to change the Temp Reset value. After using the UP and DOWN arrows to adjust to the desired setpoint, the ENTER/ADV key must be pressed to enter this number into memory.

The low limit, high limit, and default values for the keys under “SETPOINTS” are listed in Table 14.

### Schedule/Advance Day Key

The SCHEDULE is a seven day daily schedule that allows one start/stop time per day. The schedule can be programmed Monday through Sunday with an alternate holiday schedule available. If no start/stop times are programmed, the unit will run on demand, providing the unit is not shut off on a unit or system shutdown. The daily schedule is considered “not programmed” when the times in the schedule are all zeros (00:00 AM).

To set the schedule, press the SCHEDULE/ADVANCE DAY key. The display will immediately show the following display.

```

MON  START  =  00 : 00  AM
      STOP   =  00 : 00  AM
  
```

The line under the 0 is the cursor. It may be changed by using the ↑ (UP) and ↓ (DOWN) arrow keys until correct. Pressing the ENTER/ADV key will enter the times and then move the cursor to the minute box. The operation is then repeated if necessary. This process may be followed until the hour, minutes, and meridian (AM or PM) of both the START and STOP points are set. After changing the meridian of the stop time, pressing the ENTER/ADV key will advance the schedule to the next day.

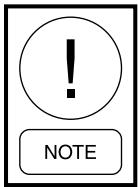

***Whenever the daily schedule is changed for Monday, all the other days will change to the new Monday schedule. This means if the Monday times are not applicable for the whole week then the exceptional days would need to be reprogrammed to the desired schedule.***

To page to a specific day press the SCHEDULE/ADVANCE DAY key. The start and stop time of each day may be programmed differently using the ↑ (UP) and ↓ (DOWN) arrow, and ENTER/ADV keys.

After SUN (Sunday) schedule appears on the display a subsequent press of the SCHEDULE/ADVANCE DAY key will display the Holiday schedule. This is a two part display. The first reads:

```

HOL  START  =  00 : 00  AM
      STOP   =  00 : 00  AM
  
```

The times may be set using the same procedure as described above for the days of the week. After changing the meridian of the stop time, pressing the ENTER/ADV key will advance the schedule to the following display:

```

S _ M T W T F S
H O L I D A Y N O T E D B Y *
  
```

The line below the empty space next to the S is the cursor and will move to the next empty space when the ENTER/ADV key is pressed. To set the Holiday, the cursor is moved to the space following the day of the week of the holiday and the ↑ (UP) arrow key is pressed. An \* will appear in the space signifying that day as a holiday. The \* can be removed by pressing the ↓ (DOWN) arrow key.

The Holiday schedule must be programmed weekly. Once the holiday schedule runs, it will revert to the normal daily schedule.

### Program Key

There are ten operating parameters under the PROGRAM key that are programmable. These setpoints can be changed by pressing the PROGRAM key, and then the ENTER/ADV key to enter *Program Mode*. Continuing to press the ENTER/ADV key will display each operating parameter. While a particular parameter is being displayed, the ↑ (UP) and ↓ (DOWN) arrow keys can be used to change the value. After the value is changed, the ENTER/ADV key must be pressed to enter the data into memory. Table 15 shows the programmable limits and default values for each operating parameter.

The following are the displays for the programmable values in the order they appear:

```

D I S C H A R G E   P R E S S U R E
C U T O U T   =   5 7 0   P S I G
  
```

DISCHARGE PRESSURE CUTOUT is the discharge pressure at which the system will shutdown as monitored by the *optional* discharge transducer. This is a software shutdown that acts as a backup for the mechanical high pressure switch located in the refrigerant circuit. The system can restart when the discharge pressure drops 40 PSIG (2.76 BARG) below the cutout point.

If the optional discharge pressure transducer is not installed, this programmable safety would not apply. It should be noted that every system has a mechanical high pressure cutout that protects against excessive high discharge pressure regardless of whether or not the optional discharge pressure is installed.

**S U C T I O N P R E S S U R E  
 C U T O U T = 8 0 . 0 P S I G**

The SUCTION PRESSURE CUTOUT protects the unit from a coil freeze-up or compressor damage. If the suction pressure drops below the cutout point, the system will shut down.

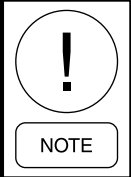
 *There are some exceptions when the suction pressure is permitted to temporarily drop below the cutout point. Details are explained under the topic of System Safeties.*

**L O W A M B I E N T T E M P  
 C U T O U T = 2 5 . 0 ° F**

The LOW AMBIENT TEMP CUTOUT allows the user to select the unit outside ambient temperature cutout point. If the ambient falls below this point, the unit will shut down. Restart can occur when temperature rises 2°F (1.11°C) above the cutout setpoint.

**A N T I R E C Y C L E T I M E R  
 = 6 0 0 S E C**

The programmable anti-recycle timer assures that systems do not cycle. This timer is programmable under the PROGRAM key between 300 - 600 seconds. Whenever possible, to reduce cycling and motor heating, the anti-recycle timer should be adjusted as high as possible. The programmable anti-recycle timer starts the timer when the first compressor in a system starts. The timer begins to count down. If all the compressors in the circuit cycle OFF, a compressor within the circuit will not be permitted to start until the anti-recycle timer has timed out. If the lead system has run for less than 5 minutes, 3 times in a row, the anti-recycle timer will be extended to 10 minutes maximum.

**F A N C O N T R O L O N  
 P R E S S U R E = X X X P S I G**

The Fan Control On-Pressure is the programmed pressure value that is used to stage the condenser fans ON, in relation to discharge pressure. Refer to Condenser Fan Control in the UNIT OPERATION section and Tables 20, 21 and 22.

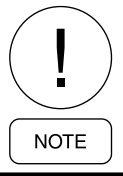
 *The microprocessor will not allow programming the “FAN CONTROL ON PRESSURE” minus the “FAN CONTROL DIFFERENTIAL OFF PRESSURE” below 160PSIG. This assures discharge pressure does not drop too low.*

**F A N D I F F E R E N T I A L O F F  
 P R E S S U R E = X X X P S I G**

The Fan Differential Off Pressure is the programmed differential pressure value that is used to stage the condenser fans OFF, in relation to discharge pressure. Refer to Condenser Fan Control in the UNIT OPERATION section and Tables 20, 21 and 22.

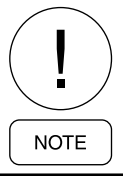
 *The microprocessor will not allow programming the “FAN CONTROL ON PRESSURE” minus the “FAN CONTROL DIFFERENTIAL OFF PRESSURE” below 160PSIG. This assures discharge pressure does not drop too low.*

**T O T A L N U M B E R O F  
 C O M P R E S S O R S = 6**

The TOTAL NUMBER OF COMPRESSORS is the amount of compressors in the unit, and determines the stages of cooling available. Notice in Table 15 that the selection available will vary depending on the unit type (single or two system).

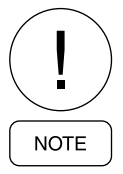
 *This MUST be programmed correctly to assure proper condensing unit operation.*

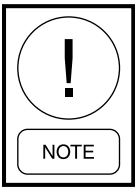

***A single system condensing unit MUST have a jumper between terminals 13 - 17 on terminal block XTBC1. If the jumper is not installed, the unit will act as a 2-system unit. The jumper is only checked by the microboard at unit power-up. If the jumper is removed, power must be removed and re-applied to register the change in memory.***

**NUMBER OF FANS  
PER SYSTEM = X**

The number of fans per system is programmed for the total number of fans on each system, or the total number on the condensing unit divided by 2.

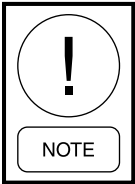

***This MUST be programmed correctly to assure proper condensing unit operation.***

**SYS X TRIP VOLTS  
= X.X VOLTS**

**UNIT TRIP VOLTS  
= X.X VOLTS**

Depending on the Current Feedback option, the trip voltage for a specific system or unit high current trip can be programmed. It also calibrates the current read-out under the OPER DATA key. The approximate programmed value is calculated using the following formulas:

### 460VAC System Trip Volts

For individual system high current trip programming on 460VAC units:

- Add the sum of the compressor and fan RLA's in the system
- Multiply the sum by 1.25
- Divide by 225A
- The resulting voltage is the value that should be programmed

For example, if fan and compressor RLA's total 100A:

$$\frac{5V \times 100A}{225A} \times 1.25 = \frac{625VA}{225A} = 2.8V$$

The programmed value will be 2.8V. A similar calculation and programming will be necessary for the other system in a 2-system unit.

### 460VAC Unit Trip Volts

For total unit high current trip programming on 460VAC units:

- Add the sum of all the compressor and fan RLA's in the unit
- Multiply the sum by 1.25
- Divide by 225A
- The resulting voltage is the value that should be programmed

For example, if fan and compressor RLA's total 180A:

$$\frac{5V \times 180A}{225A} \times 1.25 = \frac{1125VA}{225A} = 5.0V$$

The programmed value will be 5.0V.

### 208/230VAC Units

On 208/230VAC units, the process is similar, but instead of performing the calculation using 225A, a number of 450A must be substituted.

**REMOTE UNIT ID  
PROGRAMMED = X**

When communications is required with a BAS or OptiView Panel, individual unit IDs are necessary for communications with specific units on a single RS-485 line. ID 0-7 is selectable.

**TABLE 11 - COOLING SETPOINTS PROGRAMMABLE LIMITS AND DEFAULTS**

SETPOINT VALUE	LOW LIMIT	HIGH LIMIT	DEFAULT
Discharge Air Temp. Setpoint	45.0 °F	70.0°F	55.0°F
	7.2°C	21.1°C	12.7°C
Discharge Air Temp. Range	3.0°F	10.0°F	5.0°F
	1.7°C	5.6°C	2.8°C
Suction Pressure Setpoints	102 PSIG	155 PSIG	122 PSIG
	7.03 Bars	10.7 Bars	8.4 Bars
Suction Pressure Range	3 PSIG	16 PSIG	5 PSIG
	0.21 Bars	1.1 Bars	0.34 Bars
Max EMS - PWM Remote Temp. Reset	2°F	40°F	20°F
	1°C	22°C	11°C

**TABLE 12 - PROGRAM KEY LIMITS AND DEFAULTS**

PROGRAM VALUE	MODE	LOW LIMIT	HIGH LIMIT	DEFAULT
Discharge Pressure Cutout	--	325 PSIG	575 PSIG	570 PSIG
		22.4 BARG	39.6 BARG	39.3 BARG
Suction Pressure Cutout		80.0 PSIG	120.0 PSIG	80.0 PSIG
		5.52 BARG	8.27 BARG	5.52 BARG
Low Ambient Temp. Cutout	STANDARD AMBIENT	25.0°F	60.0°F	25.0°F
		-3.9°C	15.6°C	-3.9°C
	LOW AMBIENT	0°F	60.0°F	25.0°F
		-17.8°C	15.6°C	-3.9°C
Anti-Recycle Timer	--	300 SEC.	600 SEC.	600 SEC.
Fan Control On Pressure	--	360 PSIG	485 PSIG	385 PSIG
		24.8 BARG	33.4 BARG	26.5 BARG
Fan Differential Off Pressure	--	80 PSIG	160 PSIG*	125 PSIG
		5.51 BARG	11.03 BARG*	8.0 BARG
Total Number Of Compressors	SINGLE SYSTEM	2	3	3
	TWO SYSTEMS	4	6	6
Number Of Fans Per System		3	4	3
Unit/System Trip Volts	CURRENT FEEDBACK OPTION ENABLED ONE PER UNIT	0.5 VOLTS	4.5 VOLTS	2 VOLTS
Remote Unit Id	--	0	7	0

\* The minimum discharge pressure allowed is 160 PSIG. The fan differential Off Pressure will be lowered to prevent going below 235 PSIG based on where the fan control On Pressure is programmed.

**TABLE 13 - SETPOINTS QUICK REFERENCE LIST**

**Oper Data Quick Reference List**

Table 13 on page 124 provides a quick reference of the setpoints list for the SETPOINTS keys.

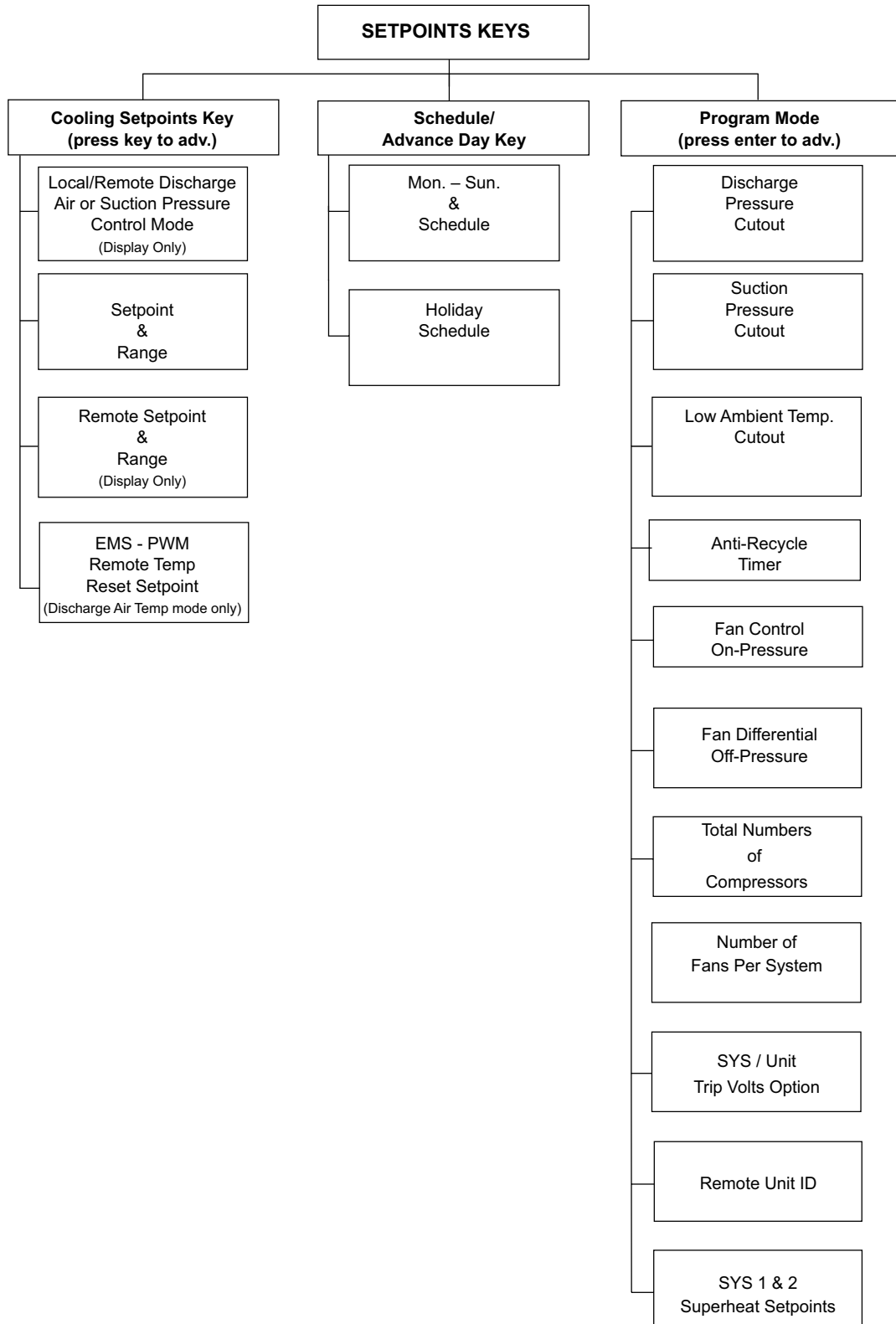



## “UNIT” KEYS

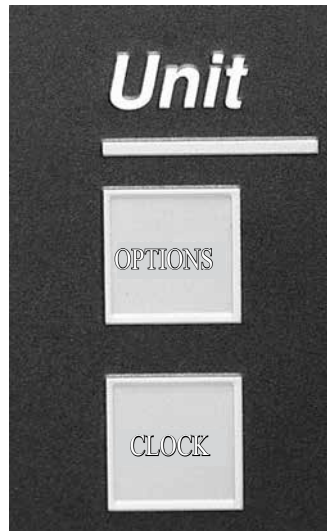

00070VIP

### Options Key

There are many user programmable options under the OPTIONS key. The OPTIONS key is used to scroll through the list of options by repeatedly pressing the OPTIONS key. After the selected option has been displayed, the ↑ (UP) and ↓ (DOWN) arrow keys are then used to change that particular option. After the option is changed, the ENTER/ADV key must be pressed to enter the data into memory. Table 17 shows the programmable options. The following are the displays in the order they appear:

#### Option 1 – Language



English, Spanish, French, German, and Italian can be programmed.

#### Option 2 System Switches

*(two system units only)*

(Single System Display is similar)



This allows both systems to run

or



This turns system 2 OFF



This turns system 1 OFF

or



This turns systems 1 and 2 OFF.

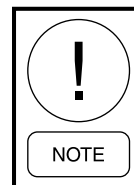

*Turning a system OFF with its system switch allows a pumpdown to be performed prior to shutdown.*

#### Option 3 – Ambient Control Type



The low ambient cutout is adjustable from 25°F to 60°F (-3.9°C to 15.6°C).

or



The low ambient cutout is programmable down to 0°F (-17.8°C). A low ambient kit **MUST** be installed for this option to be chosen. If the kit is **NOT** installed, and low ambient is selected, low pressure faults and compressor damage may occur.

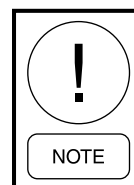

*The software may skip the low ambient selection, but a low ambient kit is still needed to operate below 25°F (-3.9°C).*

**Option 4 – Local/Remote Control Type**

LOCAL / REMOTE MODEL  
LOCAL

When programmed for LOCAL, an ISN or RCC control can be used to monitor only. The micro panel will operate on locally programmed values and ignore all commands from the remote devices. The condensing unit will communicate and send data to the remote monitoring devices.

or

LOCAL / REMOTE MODE  
REMOTE

This mode should be selected when an ISN or RCC control is to be used to control the condensing unit. This mode will allow the ISN to control the following items: Remote Start/Stop, Cooling Setpoint, Load Limit, and History Buffer Request. If the unit receives no valid ISN transmission for 5 minutes, it will revert back to the locally programmed values.

**Option 5 – Unit Control Mode**

CONTROL MODE  
SUCTION PRESSURE

Unit control is based on Suction Pressure Control.

or

CONTROL MODE  
DISCHARGE AIR

Unit control is based on Discharge Air Temp. Control.

**Option 6 – Display Units**

DISPLAY UNITS  
IMPERIAL

This mode displays system operating values in Imperial units of °F or PSIG.

or

DISPLAY UNITS  
SI

This mode displays system operating values in Scientific International units of °C or BARG.

**Option 7 – Lead/Lag Type  
(two system units only)**

LEAD / LAG CONTROL  
MANUAL SYS 1 LEAD

SYS 1 selected as lead compressor. SYS 1 lead option MUST be chosen if Hot Gas Bypass is installed.

or

LEAD / LAG CONTROL  
MANUAL SYS 2 LEAD

SYS 2 selected as lead compressor.

or

LEAD / LAG CONTROL  
AUTOMATIC

Lead/lag between systems may be selected to help equalize average run hours between systems on condensing units with 2 refrigerant systems. Auto lead/lag allows automatic lead/lag of the two systems based on an average run hours of the compressors in each system. A new lead/lag assignment is made whenever all compressors shut down. The microboard will then assign the “lead” to the system with the shortest average run time.

**Option 8 – Condenser Fan Control Mode**

FAN CONTROL  
DISCHARGE PRESSURE

Condenser fans are controlled by discharge pressure only. This mode may only be chosen when discharge pressure transducers are installed.

FAN CONTROL  
AMBIENT DSCH PRESS

Condenser fans are controlled by ambient temperature and discharge pressure. This mode must be chosen if the discharge pressure transducers are not installed.

### Option 9 – Manual Override Mode

MANUAL OVERRIDE MODE  
DISABLED

This option allows overriding of the daily schedule that is programmed. MANUAL OVERRIDE MODE – DISABLED indicates that override mode has no effect.

or

MANUAL OVERRIDE MODE  
ENABLED

Manual Override Mode is enabled. This is a service function and when enabled, will allow the unit to start when shut down on the daily schedule. It will automatically be disabled after 30 minutes.

### Option 10 – Current Feedback Options Installed

CURRENT FEEDBACK  
NONE

This mode should be selected when the panel is not equipped with current sensing capability.

or

CURRENT FEEDBACK  
ONE PER UNIT

This mode should be selected when an optional module is installed to allow combined current monitoring of all systems by sensing current on the incoming line. Current input is to J8-5 of the microboard.

or

CURRENT FEEDBACK  
ONE PER SYSTEM

This mode should be selected when an optional module is installed to allow individual current monitoring of each system. SYS 1 input is to J7-4 to J7-12 of the microboard. SYS 2 input is to J9-4 to J9-12 of the microboard.

### Option 11 – Power Fail Restart

POWER FAIL RESTART  
AUTOMATIC

Unit auto restarts after a power failure.

POWER FAIL RESTART  
MANUAL

After a power failure, the UNIT switch must be toggled before restart at the unit is allowed. NORMALLY MANUAL RESTART should NOT BE SELECTED.

### Option 12 – Soft Start Enable/Disable

SOFT START  
DISABLED

SOFT START “DISABLED” MUST be selected on all units.

This message may not be viewable on non-European units.

### Option 13 – Unit Type

UNIT TYPE  
CONDENSING UNIT

The UNIT TYPE message cannot be modified under the unit keys.

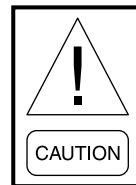

***“CONDENSING UNIT” must be displayed, or damage to compressors or other components will occur if operated in the HEAT PUMP or LIQUID CHILLER modes.***

If unit type needs to be changed to make the unit a condensing unit, add a jumper between J11-7 and J11-12, of the microboard and reapply power to the micropanel.

**Option 14 – Refrigerant Type**

REFRIGERANT TYPE  
R - 407C

Refrigerant type R-22, R-407C or R410A may be selected under Service Mode. Refrigerant type is displayed under the OPTIONS key, but is only programmable in Service Mode.



*Incorrect programming may cause damage to compressors. R-410A MUST be programmed.*

**Option 15 – Expansion Valve Type**

EXPANSION VALVE TYPE  
THERMOSTATIC

The expansion valve type must be thermostatic or electronic may be selected under Service Mode. Expansion valve type is displayed under the OPTIONS key, but is programmable in Service Mode.



*Incorrect programming may cause damage to compressors.*

Also see the *Unit Keys Programming Quick Reference List* in Table 17.

**Option 16 – Flash Card Update**

FLASH CARD UPDATE  
DISABLED

A Flash Card is used to input the operating program into the unit IPU. A Flash Card is used instead of an EPROM. Normally, a Flash Card update is not required and the message above will be displayed.

If the operating software is to be updated, insert the Flash Card into the Flash Card input port. Turn off the unit switch and set the FLASH CARD UPDATE TO “ENABLED” using the ↑ and ↓ keys.

FLASH CARD UPDATE  
ENABLED

Press the ENTER key and the following message will be displayed until the update has been completed. The keypad and display will not respond during the update. DO NOT reset or power down the unit until the update is completed.

FLASH CARD UPDATING  
PLEASE WAIT . . .

After the update is completed, an automatic reboot will occur. If an error occurred, the following message will appear with the error code and no reboot will occur.

FLASH CARD UPDATE  
ERROR XXXXX

If the update resulted in an error, the original program will still be active. When an error occurs, assure the correct Flash Card was utilized. Incorrect unit software will cause an error. If this is not the case, the Flash Card is most likely defective or the IPU and I/O combo board is bad.

**Option 17 – Remote Temperature Reset**

REMOTE TEMP RESET  
INPUT XXXXXXXXXXXXXXXX

Remote Temp Reset input selection is programmable according to the type of input utilized. The following options are available:

- DISABLED (default)
- 0.0 – 10.0VDC
- 2.0 – 10.0VDC
- 0.0 – 20.0mA
- 4.0 – 20.0mA

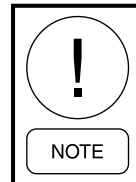

*The options display message for Remote Temp Reset Input only appears if the Temp reset Option is enabled under Service Mode.*

### Option 18 – Hot Gas Bypass Type

The Hot Gas Bypass Type must be programmed based on the option installed. Some chillers will not have hot gas bypass installed. Others will have it installed on System #1, System #2 or both systems.

The selected option is only displayed under the OPTIONS key and must be programmed under the Service Mode.

```
HOT GAS BYPASS TYPE  
NONE
```

```
HOT GAS BYPASS TYPE  
SYSTEM 1
```

```
HOT GAS BYPASS TYPE  
SYSTEM 2
```

```
HOT GAS BYPASS TYPE  
BOTH SYSTEMS
```

### Option 19– Data Logging

This should be disabled.

```
DATALOG TO FLASHCARD  
OFF
```

Also see the Unit Keys Programming Quick Reference List in Table 17.

### Clock

The CLOCK display shows the current day, time, and date. Pressing the CLOCK key will show the current day, time, and date.

It is important that the date and time be correct, otherwise the daily schedule will not function as desired if programmed. In addition, for ease of troubleshooting via the History printouts, the day, time, and date should be correct.

To change the day, time, and date press the CLOCK key. The display will show something similar to the following:

```
T O D A Y   I S   E R I   0 8 : 5 1 A M  
2 5   J A N   0 8
```

The line under the F is the cursor. If the day is correct, press the ENTER/ADV key. The cursor will move under the 0 in 08 hours. If the day is incorrect, press the ↑ (UP) or ↓ (DOWN) arrow keys until the desired day is displayed and then press the ENTER/ADV key at which time the day will be accepted and the cursor will move under the first digit of the “2 digit hour”. In a similar manner, the hour, minute, meridian, month, day, and year may be programmed, whenever the cursor is under the first letter/numeral of the item. Press the ↑ (UP) or ↓ (DOWN) arrow keys until the desired hour, minute, meridian; day, month, and year are displayed. Pressing the ENTER/ADV key will save the value and move the cursor on to the next programmable variable.

**TABLE 14 - OPTIONS KEY PROGRAMMING QUICK REFERENCE LIST**

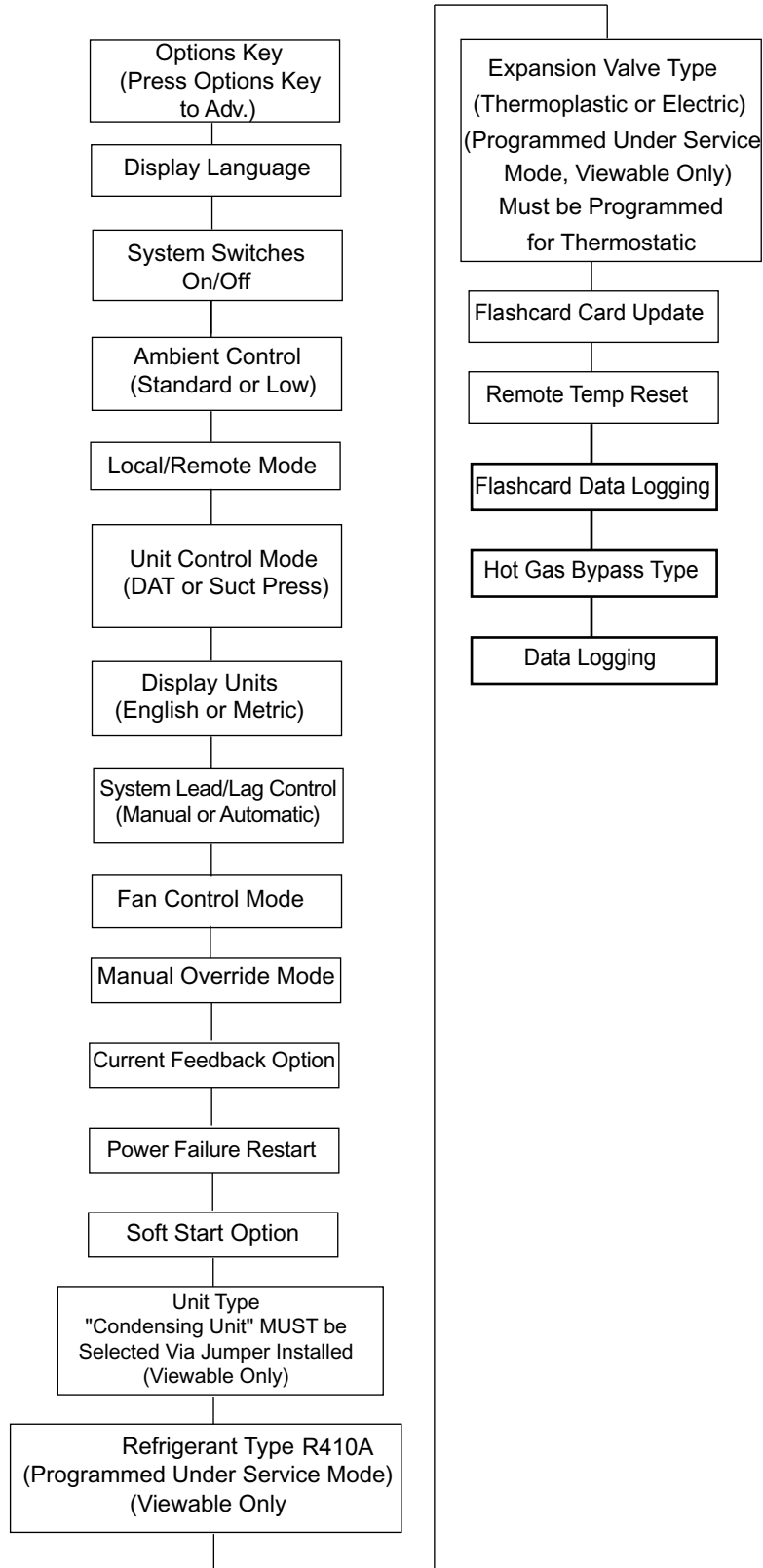

LD13348

Table 15 provides a quick reference list for the OPTIONS key setpoints.

## SECTION 8 – UNIT OPERATION

### CAPACITY CONTROL

To initiate the start sequence of the unit, all run permissive inputs must be satisfied (air proving/remote start/stop switch), and no unit or system faults exist.

The first phase of the start sequence is initiated by the Daily Schedule Start or a Remote Cycling Device. If the unit is shut down on the daily schedule, the evaporator blower contacts (Terminals 23 and 24 of XTBC2) will close when the daily schedule start time has been reached. Once the air proving switch closes, capacity control functions are initiated.

If unit cycling is accomplished with a remote cycling device wired in series with the air proving switch, the evaporator contacts will always be energized as long as the unit switch is turned ON. When the air proving switch and remote cycling contacts are closed, the capacity control functions will be initiated.

It should be noted that the evaporator contacts (Terminals 23 and 24 of XTBC2) are not required to be used to cycle the evaporator blower. However, in all cases the air proving switch must be closed to allow unit operation.

The control system will evaluate the need for cooling by comparing the actual discharge air temperature or suction pressure(s) to the desired setpoint, and regulate the discharge air temperature or suction pressure to meet that desired setpoint.

### SUCTION PRESSURE LIMIT CONTROLS

The anticipatory controls are intended to prevent the unit from ever actually reaching a low-pressure cutout. Loading is prevented, if the suction pressure drops below 1.15 x suction pressure cutout (15% below the cutout). Loading may reoccur after suction pressure rises above the unload point and a period of one minute elapses. This control is only operable if the optional suction pressure transducers are installed.

### DISCHARGE PRESSURE LIMIT CONTROLS

The discharge pressure limit controls unload a system before it reaches a safety limit due to high load or dirty condenser coils. The microboard monitors discharge pressure and unloads a system, if fully loaded, by one compressor when discharge pressure exceeds the programmed cutout minus 10 PSIG (0.69 barg). Reloading will occur when the discharge pressure on the affected system drops to 85% of the unload pressure and 10 minutes have elapsed.

This control is only applicable if optional discharge pressure transducers are installed.

### DISCHARGE AIR TEMPERATURE CONTROL

The setpoint in Discharge Air Temperature Control is the temperature the condensing unit will control to within plus or minus the control range. The setpoint High Limit is the Setpoint plus the Cooling Range. The Setpoint Low Limit is the Setpoint minus the Cooling Range. See Figure 39.

If the Discharge Air Temperature is above the Setpoint High Limit, the lead compressor on the lead system will be energized along with the liquid line solenoid. Upon energizing any compressor, the 60 second Anti-Coincidence timer will be initiated.

If after 180 seconds of run time the discharge air temperature is still above the Setpoint High Limit, the next compressor in sequence will be energized. Additional loading stages are energized at a rate of once every 180 seconds if the discharge air temperature remains above the Setpoint High Limit.

If the discharge air temperature falls below the Setpoint High Limit but is greater than the Setpoint Low Limit, loading and unloading do not occur. This area of control is called the control range.

If the discharge air temperature drops below the Setpoint Low Limit, unloading occurs at a rate of 60 seconds.

The sequences of Capacity Control (compressor staging) for loading and unloading are shown in *Table 15 on page 132* and *Table 16 on page 132*.

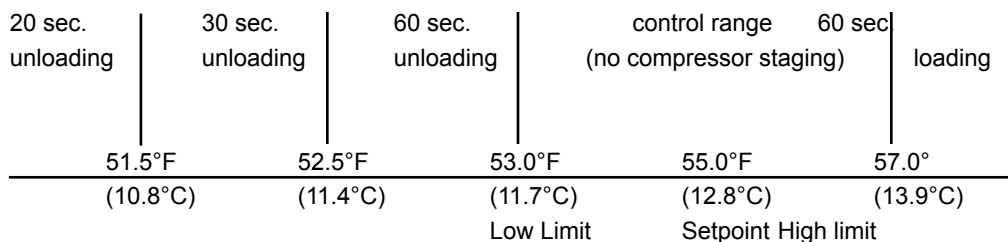

Discharge Air Temperature Control – Compressor Staging  
Setpoint = 55.0°F (12.8°C) Range = +/- 5°F (-12.2°C)

**FIGURE 38 - DISCHARGE AIR TEMPERATURE CONTROL**

**TABLE 15 - DISCHARGE AIR TEMPERATURE CONTROL FOR 5 AND 6 COMPRESSORS (7 AND 8 STEPS)**

LEAD SYSTEM				LAG SYSTEM		
*STEP	COMP 1	COMP 2	COMP 3	COMP 1	COMP 2	COMP 3
0	OFF	OFF	OFF	OFF	OFF	OFF
1	ON+HG	OFF	OFF (See Note 1)	OFF	OFF	OFF
2	ON	OFF	OFF	OFF	OFF	OFF
3	ON	OFF	OFF (See Note 2)	ON	OFF	OFF
4	ON	ON	OFF (See Note 3)	OFF	OFF	OFF
5	ON	ON	OFF	ON	OFF	OFF
6	ON	ON	OFF	ON	ON	OFF
7	ON	ON	ON	ON	ON	OFF
8	ON	ON	ON	ON	ON	ON

**NOTES:**

- Step 1 is Hot Gas Bypass and is skipped when loading occurs. Hot Gas Bypass operation is inhibited during Pumpdown. For Discharge Air Temperature Control the Hot Gas Bypass solenoid is energized only when the lead compressor is running and the DAT is less than SP, the Hot Gas Bypass solenoid is turned OFF when the DAT is more than SP + CR/2.
  - Step 3 is skipped when loading occurs.
  - Step 4 is skipped when unloading occurs.
- \* STEP can be viewed using the OPER DATA key and scrolling to COOLING DEMAND.

**TABLE 16 - DISCHARGE AIR TEMPERATURE CONTROL FOR 4 COMPRESSORS (6 STEPS)**

LEAD SYSTEM			LAG SYSTEM	
* STEP	COMP 1	COMP 2	COMP 1	COMP 2
0	OFF	OFF	OFF	OFF
1	ON+HG	OFF (See Note 1)	OFF	OFF
2	ON	OFF	OFF	OFF
3	ON	OFF (See Note 2)	ON	OFF
4	ON	ON (See Note 3)	OFF	OFF
5	ON	ON	ON	OFF
6	ON	ON	ON	ON

\* STEP can be viewed using the OPER DATA key and scrolling to COOLING DEMAND.

**NOTES:**

- Step 1 is Hot Gas Bypass and is skipped when loading occurs. Hot Gas Bypass operation is inhibited during Pumpdown. For Discharge Air Temperature Control the Hot Gas Bypass solenoid is energized only when the lead compressor is running and the DAT is less than SP, the Hot Gas Bypass solenoid is turned OFF when the DAT is more than SP + CR/2.
  - Step 3 is skipped when loading occurs.
  - Step 4 is skipped when unloading occurs.
- \* STEP can be viewed using the OPER DATA key and scrolling to COOLING DEMAND.



## SUCTION PRESSURE CONTROL

The setpoint in Suction Pressure Control is the suction pressures each individual system on the condensing unit will control to within plus or minus the cooling range. The Setpoint High Limit is the Setpoint plus the Cooling Range. The Setpoint Low Limit is the Setpoint minus the Cooling Range. Each system is controlled independently of each other according to its setpoint and cooling range.

Each system must have its own zone thermostat. If the respective zone thermostat is closed, the lead compressor on that system will be energized. In addition the liquid line solenoid to that system will be energized. Upon energizing any compressor the 60 second Anti-Coincidence timer will be initiated.

If after 150 seconds of run-time the suction pressure is still above the Setpoint High Limit, the next compressor in sequence will be energized. Additional loading stages are energized at a rate of once every 150 seconds if the suction pressure remains above the Setpoint High Limit. Each system will have its own load timer of 150 seconds.

If the suction pressure falls below the Setpoint High Limit and greater than the Setpoint Low Limit, loading and unloading do not occur. This area of control is called the control range.

If the suction pressure falls below the Setpoint Low Limit, unloading (compressors cycling OFF) occurs at a rate of 30 seconds per system. The zone thermostat must be satisfied before the last compressor in the system cycles OFF, even if the suction pressure is below the Setpoint Low Limit.

Hot Gas Bypass solenoid will be energized as the last stage of unloading. If the zone thermostat calls for cooling when the suction pressure is below the Setpoint Low Limit, the first stage compressor will be energized with the hot gas solenoid.

It should be noted that the zone thermostat has ultimate control. As long as the zone thermostat is calling for cooling, at least one compressor will be running, regardless of whether the suction pressure is below Setpoint Low Limit.

Figure 40 illustrates loading and unloading in Suction Pressure Control Mode. Refer to section on SETPOINTS keys for programmable values.

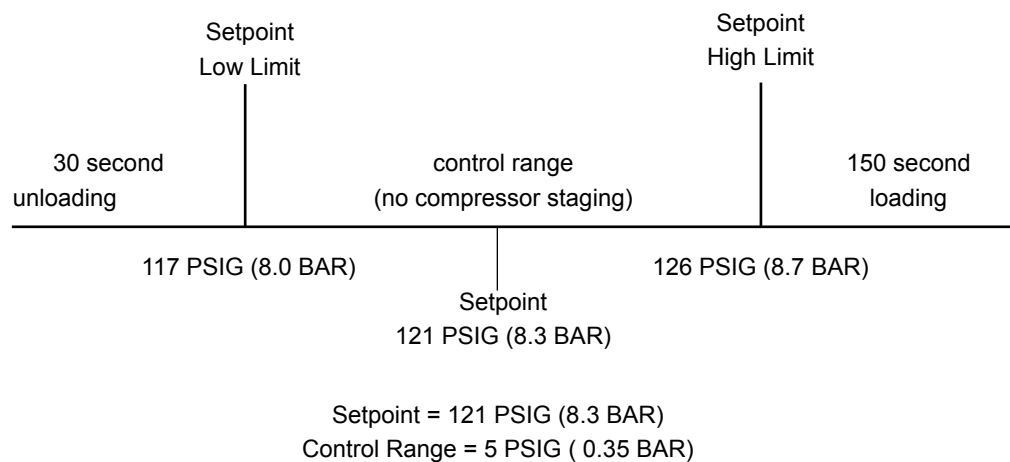

**FIGURE 39 - SUCTION PRESSURE CONTROL**

**SYSTEM LEAD/LAG**

(Discharge Air Temp Control Only)

Lead/lag between systems may be selected to help equalize average run hours between systems on condensing units with two refrigerant systems. This may be programmed under the OPTIONS key. Auto lead/lag allows automatic lead/lag of the two systems based on average run hours of the compressors in each system. Manual lead/lag selects specifically the sequence in which the microboard starts systems. Systems in Suction Pressure Control act independently based on the individual Suction Pressure Control setpoints.

**COMPRESSOR LEAD/LAG**

The compressors within a system rotate starts in sequence 1, 2 or 1, 2, 3 with wraparound. The longest OFF compressor in a system will start first, and the longest-running compressor in a system will turn OFF first. When unloading, the system with the most compressors on unloads first. The lag system will shut down a compressor first when equal numbers of compressors are operating in each system. The microboard will not attempt to equalize run time of compressors in a system.

Once the second system has started a compressor, the microboard will attempt to equally load each system. Once this occurs, loading will alternate between systems.

If Soft Start is enabled on European models with this option, compressor lead/lag will function as outlined in Option 12 under the OPTIONS key.

**ANTI-RECYCLE TIMER**

The programmable anti-recycle timer assures that systems do not cycle. This timer is programmable under the PROGRAM key between 300 and 600 seconds. Whenever possible, to reduce cycling and motor heating, the anti-recycle timer should be adjusted to 600 seconds. The programmable anti-recycle timer starts the timer when the first compressor in a system starts. The timer begins to count down. If all of the compressors in a circuit cycle OFF, a compressor within the circuit will not be permitted to start until the anti-recycle timer has timed out. If the lead system has run for less than five minutes, three times in a row, the anti-recycle timer will be extended to 10 minutes.

**ANTI-COINCIDENCE TIMER**

This timer is not present on single-system units. Two timing controls are present in software to assure compressors within a circuit or between systems, do not start simultaneously. The anti-coincidence timer assures there is at least a one minute delay between system starts on two circuit systems. This timer is NOT programmable. The load timers further assure that there is a minimum time between compressor starts within a system.

**EVAPORATOR BLOWER CONTROL**

The evaporator blower start contacts (XTBC2 - terminals 23 - 24) are energized when any of the following conditions are true:

1. Any compressor is running.
2. Daily Schedule is not programmed OFF and Unit Switch is ON.

The contacts will not close if the micropanel has been powered up for less than 30 seconds or if the contacts have been closed in the last 30 seconds to prevent motor overheating. These contacts can be used to start the evaporator blower, and for all practical purposes, will be running in a “constant fan” mode. However, if the blower is desired to cycle with the compressors, then cycling of the evaporator blower can be achieved by using the “Run Contacts” located at or XTBC2 - terminals 27 to 28 for system two (if applicable).

**EVAPORATOR HEATER CONTROL**

The evaporator heater is controlled by ambient air temperature. When the ambient temperature drops below 40 °F (4.4 °C) the heater is turned ON. When the temperature rises above 45 °F (7.2 °C) the heater is turned OFF. An under voltage condition will keep the heater off until full voltage is restored to the system.

**PUMPDOWN CONTROL**

Each system has a pump-down feature upon shut-off. Manual pumpdown from the keypad is possible by turning off the respective system’s switch under the OPTIONS key. On a non-safety, non-unit switch shutdown, all compressors but one in the system will be shut OFF. The LLSV will also be turned OFF. The final compressor will be allowed to run until the suction pressure falls below the cutout, or for 180 seconds, whichever comes first

**TABLE 17 - QCC2015C – QCC2070C CONDENSER FAN CONTROL USING OUTDOOR AMBIENT TEMPERATURE AND DISCHARGE PRESSURE (DISCHARGE PRESSURE CONTROLS WILL NOT FUNCTION UNLESS THE OPTIONAL DISCHARGE PRESSURE TRANSDUCER IS INSTALLED)**

FAN STAGE	ON	OFF	CONTACTOR		I/O BOARD OUTPUT		FAN #	
			SYS 1	SYS 2	SYS 1	SYS 2	SYS 1	SYS 2
1 1 FAN FWD	OAT >25°F (-3.9°C) or DP > Fan Ctrl On Press	OAT < 20°F (-6.7°C) and DP < Fan Ctrl On Press – (Diff. Press.)	8M	11M	TB7-9	TB10-9	3	4
*3 2 FANS FWD	OAT >65°F (18.3°C) or DP > Fan Ctrl On Press + 40 PSIG (2.76 Bars)	OAT < 60°F (15.6°C) and DP < Fan Ctrl On Press.- [Diff. Press + 40 PSIG (2.76 Bars)]	7M & 8M	10M & 11M	TB7-8 & TB7-9	TB10-8 & TB10-9	1 & 3	2 & 4

**TABLE 18 - QCC2040C – QCC2070C CONDENSER FAN CONTROL USING DISCHARGE PRESSURE ONLY**

FAN STAGE	ON	OFF	CONTACTOR		I/O BOARD OUTPUT		FAN #	
			SYS 1	SYS 2	SYS 1	SYS 2	SYS 1	SYS 2
1 1 FAN FWD	DP > Fan Ctrl On Press	DP < Fan Ctrl On Press – (Diff. Press.)	8M	11M	TB7-9	TB10-9	3	4
*3 2 FANS FWD	DP > Fan Ctrl On Press + 40 PSIG (2.76 Bars)	DP < Fan Ctrl On Press.) – [(Diff Press.) + 40 PSIG (2.76 Bars)]	7M & 8M	10M & 11M	TB7-8 & TB7-9	TB10-8 & TB10-9	1 & 3	2 & 4

\* NOTE: STEP 2 is not active in the “Standard Ambient” mode. When changing to “Low Ambient” control, fan power wiring also changes.

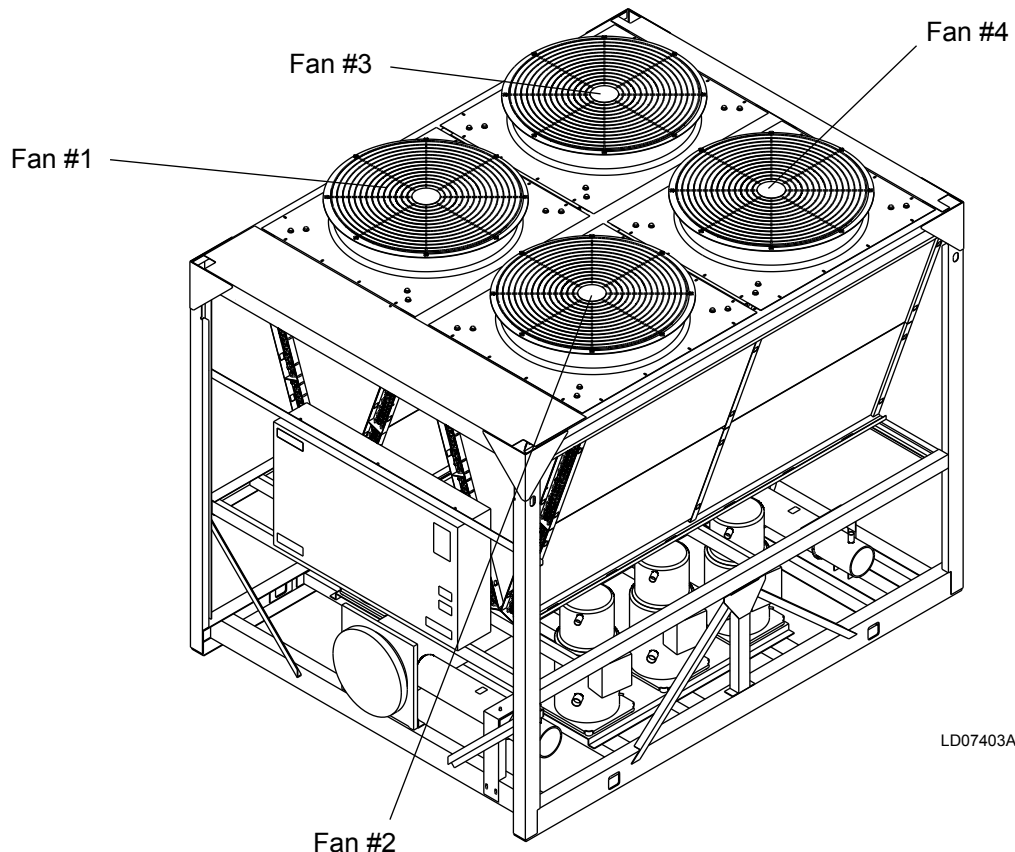

**FIGURE 40 - QCC2040C – QCC2070C FAN LOCATION (TYPICAL)**

**CONDENSER FAN CONTROL - QCC2015C – QCC2070C****TABLE 19 - QCC2015C – QCC2070C LOW AMBIENT CONDENSER FAN CONTROL – DISCHARGE PRESSURE CONTROL**

FAN STAGE	ON	OFF	CONTACTOR		I/O BOARD OUTPUT		FAN #	
			SYS 1	SYS 2	SYS 1	SYS 2	SYS 1	SYS 2
1 1 FAN REV	DP > Fan Ctrl On Press	DP < Fan Ctrl On Press – Diff. Press.	7M	10M	TB7-8	TB10-8	1 REV	2 REV
2 1 FAN FWD	DP > Fan Ctrl On Press + 20 PSIG (1.38 Bars)	DP < Fan Ctrl On Press.) – [Diff Press. + 20 PSIG (1.38 Bars)]	8M	11M	TB7-9	TB10-9	3 FWD	4 FWD
3 2 FANS FWD	DP > Fan Ctrl On Press + 40 PSIG (2.76 Bars)	DP < Fan Ctrl On Press.) – [Diff Press. + 40 PSIG (2.76 Bars)]	8M & 9M	11M & 12M	TB7-9 & TB7-10	TB10-9 & TB10-10	1 & 3 FWD	2 & 4 FWD

**TABLE 20 - QCC2015C – QCC2030C LOW AMBIENT CONDENSER FAN CONTROL – DISCHARGE PRESSURE CONTROL**

FAN STAGE	ON	OFF	CONTACTOR	I/O BOARD OUTPUT	FAN #
Stage 1	"OAT > 25° F or DP > ctrl_press"	"OAT < 20° F and DP < ctrl_press - diff_press"	7M	TB7-8	1 REV
Stage 2	"OAT > 45° F or DP > ctrl_press + 20 PSIG"	"OAT < 40° F and DP < ctrl_press - diff_press + 20 PSIG"	8M	TB7-9	3 FWD

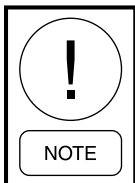

*When Low Ambient Control of the fans is selected, fan control will be by discharge pressure only.*

## LOAD LIMITING

Load Limiting is a feature that prevents the unit from loading beyond the desired value. Two and four compressor units can be load limited to 50%. This would allow only one compressor per system to run. three and six compressor units can be load limited to 33% or 66%. The 66% limit would allow up to two compressors per system to run, and the 33% limit would allow only one compressor per system to run. Five compressor units may be load limited to 40% (one compressor per system runs) or 80% (up to two compressors per system) are permitted to run. No other values of limiting are available.

There are two ways to load limit the unit. The first is through remote communication via an ISN. A second way to load limit the unit is through closing contacts connected to the Load Limit (XTBC1 – terminals 13-21) and PWM inputs (XTBC1 – terminals 13-20). Stage 1 of load limiting involves closing the Load Limit input. Stage 2 of load limiting involves closing both the Load Limit and PWM inputs. The first stage of limiting is either 80%, 66% or 50%, depending on the number of compressors on the unit. The second stage of limiting is either 40% or 33% and is only available on 3, 5 and 6 compressor units. *Table 21 on page 137* shows the load limiting permitted for the various numbers of compressors.

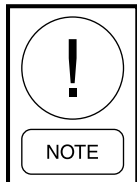

***Simultaneous operation of Remote Load Limiting and EMS-PWM Temperature Reset (described on following pages) cannot occur.***

## COMPRESSOR RUN STATUS

Compressor run status is indicated by closure of contacts at XTBC2 – terminals 25 to 26 for system 1 and XTBC2 – terminals 27 to 28 for system 2. The respective contact will close anytime a compressor is running in that particular system.

The compressor Run Status contacts can also be used to cycle the evaporator fan contactor with the compressors.

## ALARM STATUS

System or unit shutdown is indicated by normally-open contacts opening whenever the unit shuts down on a unit fault, or locks out on a system fault. System 1 alarm contacts are located at XTBC2 - terminals 29 to 30. System 2 alarm contacts are located at XTBC2 - terminals 31 to 32. The alarm contacts will close when conditions allow the unit to operate.

**TABLE 21 - COMPRESSOR OPERATION – LOAD LIMITING**

COMPRESSORS IN UNIT	STAGE 1	STAGE 2
2	50%	-
3	66%	33%
4	50%	-
5	80%	40%
6	66%	33%

## BAS/EMS DISCHARGE AIR TEMPERATURE RESET USING A VOLTAGE OR CURRENT SIGNAL

The Remote Reset Option allows the Control Center of the unit to reset the discharge air temperature setpoint using a 0 - 10VDC input, or a 4-20mA input connected to XTBC1 terminals A- and A+. Whenever a reset is called for, the change may be noted by pressing the COOLING SETPOINTS key twice. The new value will be displayed as “REM SETP = XXX °F.”

If a 0 - 10VDC signal is supplied, it is applied to terminals A+ and A-, and jumper JP1 on the I/O board must be inserted between pins 2 and 3. To calculate the reset discharge air temperature setpoint for values between 0VDC and 10VDC use the following formula:

$$\text{Setpoint} = \text{Local Discharge Air Temp Setpoint} + \text{°Reset}$$

$$\text{°Reset} = \frac{(\text{DC voltage signal}) \times (\text{*Max Reset Value})}{10}$$

Example:

$$\text{Local Discharge Air Temp Setpoint} = 45 \text{ °F (7.22 °C)}$$

$$\text{*Max Reset Value} = 20 \text{ °F (11.11 °C)}$$

$$\text{Input Signal} = 6\text{VDC}$$

(English)

$$\text{°Reset} = \frac{6\text{VDC} \times 20 \text{ °F}}{10} = 12 \text{ °F Reset}$$

$$\text{New Setpoint} = 45 \text{ °F} + 12 \text{ °F} = 57 \text{ °F}$$

(Metric)

$$\text{°Reset} = \frac{6\text{VDC} \times 11.11 \text{ °C}}{10} = 6.67 \text{ °C Reset}$$

$$\text{New Setpoint} = 7.22 \text{ °C} + 6.67 \text{ °C} = 13.89 \text{ °C}$$

\*Max Reset Value is the “Max EMS-PWM Remote Temp. Reset” setpoint value described in the programming section under Cooling Setpoints. Programmable values are from 2 °F to 40 °F (1.11 °C to 11.11 °C).

**\*\*NOTE:** The Suction Pressure Setpoints are not remotely resettable.

If a 4-20mA signal is supplied, it is applied to terminals A+ and A- and jumper JP1 on the I/O board must be installed between pin 1 and 2. To calculate the discharge air temperature setpoint for values between 4mA and 20mA use the following formula:

$$\text{Setpoint} = \text{Local Discharge Air Temp Setpoint} + \text{°Reset}$$

$$\text{°Reset} = \frac{(\text{mA signal} - 4) \times (\text{*Max Reset Value})}{16}$$

Example:

$$\text{Local Discharge Air Temp Setpoint} = 45 \text{ ° (7.22 °C)}$$

$$\text{*Max Reset Value} = 10 \text{ °F (5.56 °C)}$$

$$\text{Input Signal} = 12\text{mA}$$

(English)

$$\text{°Reset} = \frac{8\text{mA} \times 10 \text{ °F}}{16} = 5 \text{ °F Reset}$$

$$\text{Setpoint} = 45 \text{ °F} + 5 \text{ °F} = 50 \text{ °F}$$

(Metric)

$$\text{°Reset} = \frac{8\text{mA} \times 5.56 \text{ °C}}{16} = 2.78 \text{ °C Reset}$$

$$\text{Setpoint} = 7.22 \text{ °C} + 2.78 \text{ °C} = 10.0 \text{ °C}$$

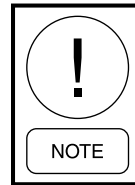

***A 240-24 Volt Ratio Transformer (T3) is used to derive nominal 12 volt output from the 120 volt supply.***

## SECTION 9 – SERVICE AND TROUBLESHOOTING

### CLEARING HISTORY BUFFERS

The history buffers may be cleared by pressing the HISTORY key and then repeatedly pressing the UP arrow key until you scroll past the last history buffer choice. The following message will be displayed:

```

    I N I T I A L I Z E   H I S T O R Y
    E N T E R   =   Y E S
    
```

Pressing the ENTER/ADV key at this display will cause the history buffers to be cleared. Pressing any other key will cancel the operation.

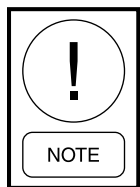

***DO NOT CLEAR BUFFERS. Important information may be lost. Contact factory service.***

### SERVICE MODE

Service Mode is a mode that allows the user to enable or disable all of the outputs (except compressors) on the unit, change unit configuration setup parameters and view all the inputs to the microboard.

To enter Service Mode, turn the Unit Switch off and press the following keys in the following sequence: PROGRAM, UP ARROW, UP ARROW, DOWN ARROW, DOWN ARROW, ENTER.

Service Mode will time out after 30 minutes and return to normal control mode, if the panel is accidentally left in this mode. Otherwise, turning the unit switch on will take the panel out of Service Mode.

### SERVICE MODE – OUTPUTS

After pressing the key sequence as described, the control will enter Service Mode permitting the outputs (except compressors), operating hours, refrigerant type, expansion valve type, and start/hour counters to be viewed/modified. The ENTER/ADV key is used to advance through the outputs. Using the ↑ and ↓ (UP/DOWN) arrow keys will turn the respective digital output ON/OFF or modify the value.

The following is the order of outputs that will appear as the ENTER/ADV key is pressed:

```

    SYS 1 COMP 1 STATUS TB7-2 IS:
    SYS 1 LLSV STATUS TB7-3 IS:
    SYS 1 COMP 2 STATUS TB7-4 IS:
    SYS 1 COMP 3 STATUS TB7-5 IS:
    SYS 1 HGBP STATUS TB7-7 IS:
    SYS 2 COMP 1 STATUS TB10-2 IS:
    SYS 2 LLSV STATUS TB10-3 IS:
    SYS 2 COMP 2 STATUS TB10-4 IS:
    SYS 2 COMP 3 STATUS TB10-5 IS:
    SYS 1 FAN OUTPUT 1 TB7-8 IS:
    SYS 1 FAN OUTPUT 2 TB7-9 IS:
    SYS 1 FAN OUTPUT 3 TB7-10 IS:
    SYS 2 FAN OUTPUT 1 TB10-8 IS:
    SYS 2 FAN OUTPUT 2 TB10-9 IS:
    SYS 2 FAN OUTPUT 3 TB10-10 IS:
    EVAP HEATER STATUS TB8-2 IS:
    SYS 1 ALARM STATUS TB8-3 IS:
    SYS 2 ALARM STATUS TB9-2 IS:
    EVAP PUMP STATUS TB8-6,7 IS:
    SYS 2 HGBV STATUS TB10-7 IS:
    SPARE DO TB8-4 IS:
    SPARE DO TB8-5 IS:
    SPARE DO TB8-8, 9 IS:
    SPARE DO TB9-4 IS:
    SYS 1 EEV OUTPUT TB5-1, 2 = XXX%
    SYS 2 EEV OUTPUT TB6-1, 2 = XXX%
    SYS 1 COND FAN SPEED J15-1,5 = XXX%
    SYS 2 COND FAN SPEED J15-2,6 = XXX%
    SPARE AO J15-3,7 = XXX%
    SPARE AO J15-4,8 = XXX%
    DATA LOGGING MODE 1 = ON, 0 = OFF
    
```

Each display will also show the output connection on the microboard for the respective output status shown. For example:

```

    S Y S   1   L L S V   S T A T U S
    T B 1 0 - 3   I S   O F F
    
```

This display indicates that the system 1 liquid line solenoid valve is OFF, and the output connection from the microboard is coming from Terminal Block 10 – pin 3.

Pressing the ↑ (UP) arrow key will energize the liquid line solenoid valve (LLSV) and “OFF” will change to “ON” in the display as the LLSV is energized. Energizing and de-energizing outputs may be useful during troubleshooting.

## SERVICE MODE – CONDENSING UNIT CONFIGURATION

After the Outputs are displayed, the next group of displays relate to unit configuration and start/hour counters. Data logging, soft start, refrigerant type, pump control selection, and expansion valve type all must be programmed to match the actual unit configuration.



***Soft start (disabled), Refrigerant Type (R410A), and Expansion Valve Type (Thermostatic), and North American Feature (Enabled) MUST be properly programmed or damage to compressors and other system components may result.***

The following is a list of unit configuration selections, in order of appearance:

HOT GAS BYPASS TYPE  
UNIT TYPE (STANDARD OR HEAT PUMP)  
COMPRESSOR HOURS  
COMPRESSOR STARTS  
DATA LOGGING TIMER X SECS  
FAN CONTROL TYPE (SINGLE)  
SOFT START (DISABLED)  
REFRIGERANT TYPE (R410A ONLY)  
EXPANSION VALVE TYPE (THERMOSTATIC ONLY)  
REMOTE TEMP RESET OPTION =  
REMOTE INPUT SERVICE TIME =  
“NORTH AMERICAN FEATURE SET ENABLED”  
HYDRO PUMP SELECTION  
EVAP PUMP TOTAL RUN HOURS  
SYS 1 HOURS  
SYS 2 HOURS  
SYS 1 STARTS  
SYS 2 STARTS

The last displays shown on the above list are for the accumulated run and start timers for each system. All values can also be changed using the ↑ (UP) and ↓ (DOWN) arrow keys, but under normal circumstances would not be required or advised. After the last start display, the microboard will display the first programmable value under the PROGRAM key.

## SERVICE MODE – ANALOG AND DIGITAL INPUTS

After entering Service Mode (PROGRAM ↑↑ ↓↓), all digital and analog inputs to the microboard can be viewed by pressing the OPER DATA key. After pressing the OPER DATA key, the ↑ (UP) arrow and ↓ (DOWN) arrow keys are used to scroll through the analog and digital inputs.

The following is the order of analog and digital inputs that will appear when sequenced with the ↓ (DOWN) arrow key:

(analog inputs)  
SYS 1 SUCT PRESSURE  
UNIT TYPE  
SYS 1 \*DISCH PRESSURE  
SYS 1\*\* SUCTION TEMP.  
SYS 2\*\* SUCTION TEMP.  
AMBIENT AIR TEMP.  
LEAVING LIQUID TEMP.  
RETURN LIQUID TEMP.  
SYS 2 SUCTION PRESSURE  
SYS 2 SPARE  
SYS 2 \*DISCH PRESSURE  
SYS 1 MTR VOLTS  
SYS 2 MTR VOLTS  
  
(DIGITAL INPUTS)  
PWM TEMP RESET INPUT  
LOAD LIMIT INPUT  
FLOW SW / REM START  
SPARE  
SINGLE SYSTEM SELECT  
SYS 1 MP / HPCO INPUT  
SYS 2 MP / HPCO INPUT

\* The discharge pressure transducer is optional on some models.

\*\* The suction temperature sensor is on EEV units only.

The analog inputs will display the input connection, the temperature or pressure, and corresponding input voltage such as:

```
SYS 1 SUCT PR J7 - 10
2 . 1 VDC = 81 PSIG
```



This example indicates that the system 1 suction pressure input is connected to plug 7 – pin 10 (J7-10) on the I/O board. It indicates that the voltage is 2.1VDC which corresponds to 81 PSIG (5.6 bars) suction pressure.

The digital inputs will display the input connection and ON/OFF status such as:



This indicates that the flow switch/remote start input is connected to plug 13- pin 5 (J13-5) on the microboard, and is ON (ON = +30VDC unregulated input, OFF = 0VDC input on digital inputs).

**CONTROL INPUTS/OUTPUTS**

Tables 24 through 27 are a quick reference list providing the connection points and a description of the inputs and outputs respectively. All input and output connections pertain to the connections at the microboard.

**TABLE 22 - I/O DIGITAL INPUTS**

<b>J13-2</b>	Unit ON/OFF Switch
<b>J13-3</b>	Load Limit Stage 2 on 3, 5 and 6 Comp. Units
<b>J13-4</b>	Load Limit Stage 1
<b>J13-5</b>	SYS 1 Zone Thermostat
<b>J13-6</b>	SYS 2 Zone Thermostat
<b>J13-7</b>	Single System Select (Jumper = Single Sys, No Jumper = Two Sys)
<b>J13-8</b>	CR1 (Sys 1 Motor Protector/High Pressure Cutout)
<b>J13-10</b>	CR2 (Sys 2 Motor Protector/High Pressure Cutout)

**TABLE 23 - I/O DIGITAL OUTPUTS**

<b>TB7-2</b>	SYS 1 Compressor 1
<b>TB7-3</b>	SYS 1 Liquid Line Solenoid Valve
<b>TB7-4</b>	SYS 1 Compressor 2
<b>TB7-5</b>	SYS 1 Compressor 3
<b>TB7-7</b>	SYS 1 Hot Gas Bypass Valve
<b>TB10-2</b>	SYS 2 Compressor 1
<b>TB10-3</b>	SYS 2 Liquid Line Solenoid Valve
<b>TB10-4</b>	SYS 2 Compressor 2
<b>TB10-5</b>	SYS 2 Compressor 3
<b>TB7-8</b>	SYS 1 Condenser Fan Output 1
<b>TB7-9</b>	SYS 1 Condenser Fan Output 2
<b>TB7-10</b>	SYS 1 Condenser Fan Output 3
<b>TB10-8</b>	SYS 2 Condenser Fan Output 1
<b>TB10-9</b>	SYS 2 Condenser Fan Output 2
<b>TB10-10</b>	SYS 2 Condenser Fan Output 3
<b>TB8-2</b>	Evaporator Heater
<b>TB8-3</b>	SYS 1 Alarm
<b>TB9-2</b>	SYS 2 Alarm
<b>TB8-6 &amp; 7</b>	Evaporator Pump Starter
<b>TB10-7</b>	SYS 2 Hot Gas Bypass Valve

**TABLE 24 - I/O ANALOG INPUTS**

<b>J7-10</b>	SYS 1 Suction Transducer
<b>J11-12</b>	Unit Type: Chiller = NO Jumper J11-12 to +24VDC QCC2 Condensing Unit = Jumper J11-12 to +24VDC (Do NOT Use)
<b>J7-11</b>	SYS 1 Discharge Pressure Transducer (Optional)
<b>J6-9</b>	Ambient Air Temp. Sensor
<b>J6-7</b>	Leaving Chilled Liquid Temp. Sensor (Not Used)
<b>J6-8</b>	Discharge Air Temp Sensor
<b>J9-10</b>	SYS 2 Suction Pressure Transducer
<b>J9-11</b>	SYS 2 Discharge Pressure Transducer
<b>J7-12</b>	Unit/SYS 1 Voltage
<b>J9-12</b>	SYS 2 Voltage

**TABLE 25 - I/O ANALOG OUTPUTS**

<b>N/A</b>	Not Applicable
------------	----------------

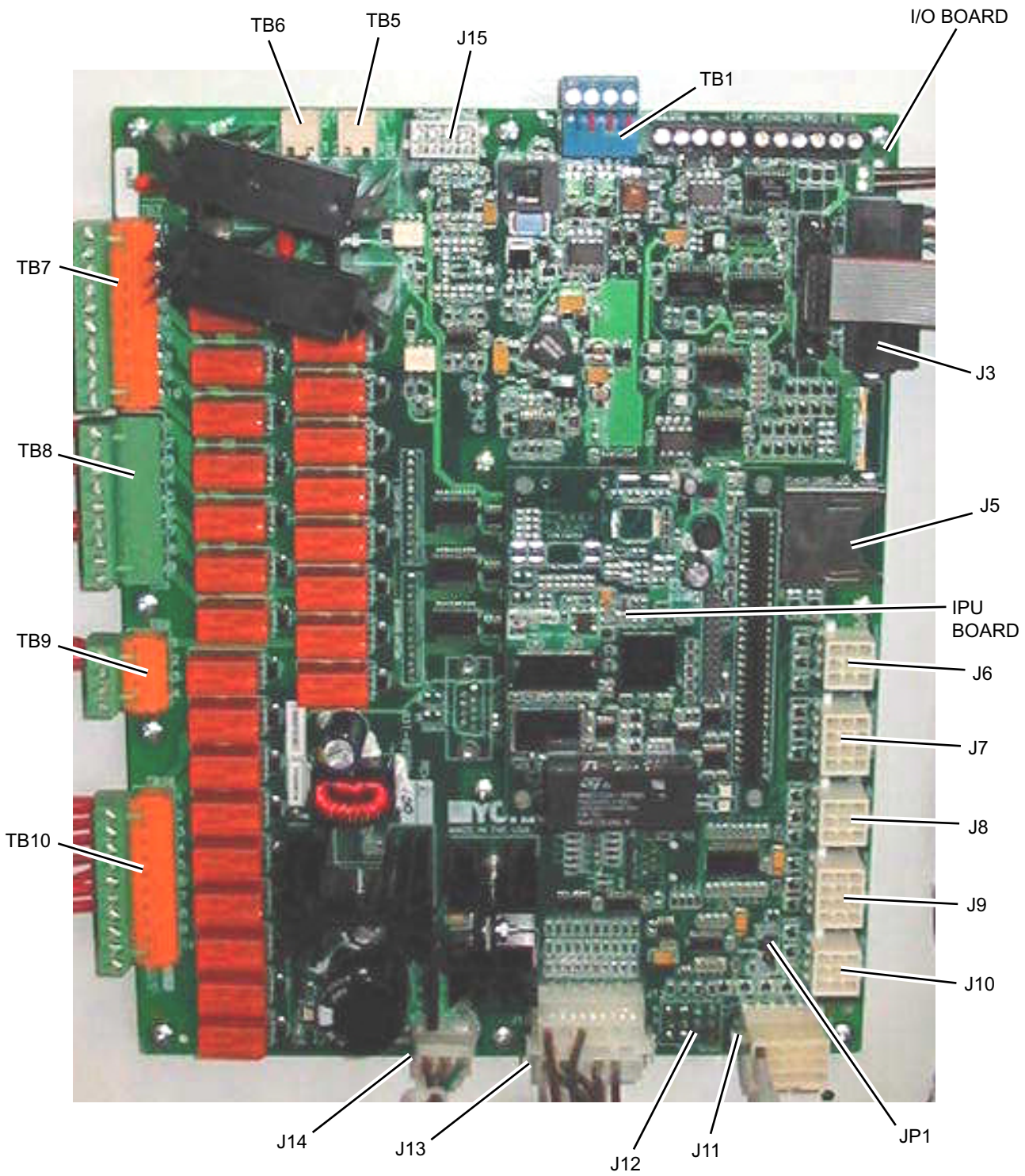

LD12721

FIGURE 41 - MICROBOARD LAYOUT

## CHECKING INPUTS AND OUTPUTS

### Digital Inputs

*Refer to the unit wiring diagram.* All digital inputs are connected to J13-1 of the I/O board. The term “digital” refers to two states – either ON or OFF. As an example, when the flow switch is closed, 30VDC will be applied to J13, pin 5 (J13-5) of the I/O board. If the flow switch is open, 0VDC will then be present at J13-5.

Pin 1 of J13 is an unregulated 30VDC source used to supply the DC voltage to the various user contacts, unit switch, flow switch, etc. This DC source is factory wired to XTBC1, terminal 13. Any switch or contact used as a digital input would be connected to this terminal, with the other end connecting to its respective digital input on the microboard. Any time a switch or contact is closed, 30VDC would be applied to that particular digital input. Any time a switch or contact is open, 0VDC would be applied to that particular digital input.

Typically, voltages of 24 – 36VDC could be measured for the DC voltage on the digital inputs. This voltage is in reference to ground. The unit case should be sufficient as a reference point when measuring digital input voltages.

### Analog Inputs – Temperature

*Refer to the unit wiring diagram.* Temperature inputs are connected to the microboard on plug J6. These **analog** inputs represent varying DC signals corresponding to varying temperatures. All voltages are in reference to the unit case (ground). The following are the connections for the temperature sensing inputs:

### Outside Air Sensor

J6-6 = +5VDC regulated supply to sensor.

J6-9 = VDC input signal to the microboard.  
 See Table 28 for voltage readings that correspond to specific outdoor temperatures.

J6-3 = drain (shield connection = 0VDC) Return

**TABLE 26 - OUTDOOR AIR SENSOR  
 TEMPERATURE/VOLTAGE/  
 CORRELATION**

TEMP °F	VOLTAGE (SIGNAL INPUT TO RETURN)	TEMP °C
0	0.7	-18
5	0.8	-15
10	0.9	-12
15	1.0	-9
20	1.1	-7
25	1.2	-4
30	1.4	-1
35	1.5	2
40	1.7	4
45	1.8	7
50	2.0	10
55	2.2	13
60	2.3	16
65	2.5	18
70	2.6	21
75	2.8	24
80	2.9	27
85	3.1	29
90	3.2	32
95	3.4	35
100	3.5	38
105	3.6	41
110	3.7	43
115	3.8	46
120	3.9	49
125	4.0	52
130	4.1	54

**TABLE 27 - DISCHARGE AIR TEMP. SENSOR  
TEMPERATURE/VOLTAGE/  
RESISTANCE CORRELATION**

TEMP °F	VOLTAGE	RESISTANCE	TEMP °C
0	1.71	25619	-18
2	1.78	24046	-17
4	1.85	22580	-16
6	1.93	21214	-14
8	2.00	19939	-13
10	2.07	18749	-12
12	2.15	17637	-11
14	2.22	16599	-10
16	2.30	15629	-9
18	2.37	14721	-8
20	2.45	13872	-7
22	2.52	13077	-6
24	2.59	12333	-4
26	2.67	11636	-3
28	2.74	10982	-2
30	2.81	10370	-1
32	2.88	9795	0
34	2.95	9256	1
36	3.02	8750	2
38	3.08	8276	3
40	3.15	7830	4
42	3.21	7411	6
44	3.27	7017	7
46	3.33	6647	8
48	3.39	6298	9
50	3.45	5970	10
52	3.51	5661	11
54	3.56	5370	12
56	3.61	5096	13
58	3.67	4837	14
60	3.72	4593	16
62	3.76	4363	17
64	3.81	4145	18
66	3.86	3941	19
68	3.90	3747	20
70	3.94	3564	21
72	3.98	3392	22
74	4.02	3228	23
76	4.06	3074	24
78	4.10	2928	26
80	4.13	2790	27

**Discharge Air Temperature Sensor**

- J6-5 = +5VDC regulated supply to sensor.
- J6-8 = vdc input signal to the microboard. See Table 29 for voltage readings that correspond to specific discharge temperatures.
- J6-2 = drain (shield connection = 0VDC)

**Analog Inputs – Pressure**

Refer to the unit wiring diagram. Pressure inputs are connected to the microboard on plugs J7 and J9. These analog inputs represent varying DC signals corresponding to varying pressures. All voltages are in reference to the unit case (ground).

System 1 discharge and suction pressures will be connected to J7 of the microboard. System 2 discharge and suction pressure transducers will be connected to J9 of the microboard.

The discharge transducers are optional on all units. If the discharge transducers are not installed, no connections are made to the microboard and the discharge pressure readout on the display would be zero.

The suction pressure transducers are standard on all QCC2's. The suction pressure transducers have a range of 0 to 400 PSIG. The output will be linear from 0.5VDC to 4.5VDC over the 400 PSIG (27.5 barg) range.

The discharge transducers have a range from 0 to 650 PSIG. The output will be linear from 0.5VDC to 4.5VDC over the 650 PSIG (41.25 barg) range. All voltage readings are in reference to ground (unit case).

**TABLE 28 - PRESSURE TRANSDUCERS**

0-400 PSIG SUCTION PRESSURE TRANSDUCER		0-650 PSIG DISCHARGE PRESSURE TRANSDUCER	
PRESSURE PSIG	VOLTAGE VDC	PRESSURE PSIG	VOLTAGE VDC
0	0.5	0	0.5
50	1.0	81.25	1.0
100	1.5	162.5	1.5
150	2.0	243.75	2.0
200	2.5	325	2.5
250	3.0	406.25	3.0
300	3.5	487.5	3.5
350	4.0	568.75	4.0
400	4.5	650	4.5

RED WIRE = 5V, BLACK WIRE = 0V, WHITE/  
 GREEN WIRE = SIGNAL

**TEST POINTS:**

**Suction Pressure:**

System 1: .....Microboard J7-10 to J7-9

System 2: .....Microboard J9-10 to J9-9

**Discharge Pressure:**

System 1: .....Microboard J7-11 to J7-7

System 2: .....Microboard J9-11 to J9-7

The I/O board connections for the Discharge Transducers:

**System 1 Discharge Transducer**

J7-6 = +5VDC regulated supply to transducer.

J7-11 =VDC input signal to the microboard. See the formula above for voltage readings that correspond to specific discharge pressures.

J7-7 = +5VDC return.

J7-2 = drain (shield connection = 0VDC).

**System 2 Discharge Transducer**

J9-6 = +5VDC regulated supply to transducer.

J9-11 = VDC input signal to the microboard. See the formula above for voltage readings that correspond to specific discharge pressures.

J9-7 = +5VDC return

J9-2 = drain (shield connection = 0VDC).

The suction transducers have a range from 0 to 400 PSIG (27.5 barg). The output will be linear from 0.5VDC to 4.5VDC over the 400 PSIG (27.5 barg) range. The following is a formula that can be used to verify the voltage output of the transducer. All voltage readings are in reference to ground (unit case).

$$V = (\text{Pressure in PSIG} \times .02) + .5$$

or

$$V = (\text{Pressure in barg} \times .29) + .5$$

where V = DC voltage input to microboard

Pressure = pressure sensed by transducer

The following are the I/O board connections for the Suction Transducer:

**System 1 Suction Transducer**

J7-5 = +5VDC regulated supply to transducer.

J7-10 = VDC input signal to the microboard.  
*See the formula above for voltage readings that correspond to specific suction pressures.*

J7-9 = +5VDC return.

J7-1 = drain (shield connection = 0VDC).

**System 2 Suction Transducer**

J9-5 = +5VDC regulated supply to transducer.

J9-10 = VDC input signal to the microboard.  
*See the formula above for voltage readings that correspond to specific suction pressures.*

J7-9 = +5VDC return.

J7-11 = drain (shield connection = 0VDC).

### Digital Outputs

Refer to the unit wiring diagram and *Figure 42 on page 146*. The digital outputs are located on TB7, TB8, and TB9 and TB-10 of the microboard. All outputs are 120VAC with the exception of TB8-6 to TB8-7 which are the contacts that can be used for a remote evaporator pump start signal. The voltage applied to either of these terminals would be determined by field wiring.

Each output is controlled by the microprocessor by switching 120VAC to the respective output connection energizing contactors, evaporator heater, and solenoids according to the operating sequence (see *Figure 42 on page 146*).

120VAC is supplied to the I/O board via connections at TB7-1, TB7-6, TB10-1, TB10-6, TB8-1 and TB9-1. Figure 43 illustrates the relay contact architecture on the microboard.

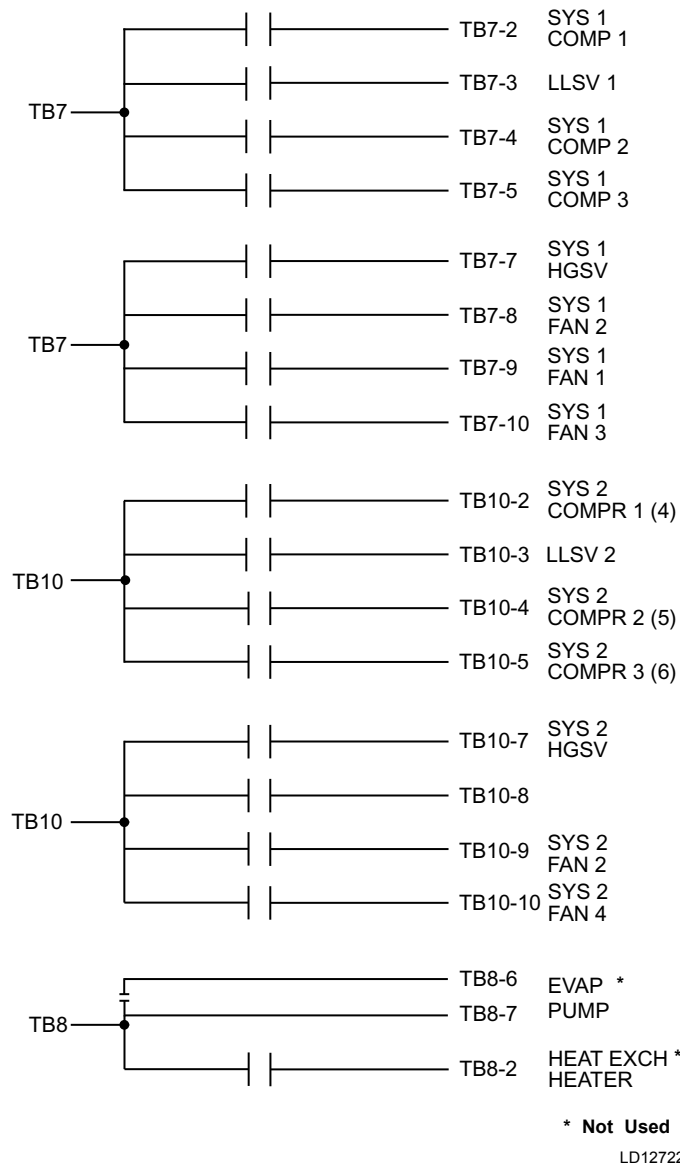

**FIGURE 42 - I/O BOARD RELAY CONTACT ARCHITECTURE**

## OPTIONAL PRINTER INSTALLATION

The micro panel is capable of supplying a printout of unit conditions or fault shutdown information at any given time. This allows operator and service personnel to obtain data and system status with the touch of the keypad. In addition to manual print selection, the micro panel will provide an automatic printout whenever a fault occurs. Detailed explanation of the print function is given under “Print Key” located in the Keypad and Display section.

Quantech recommends the field tested WEIGH-TRONIX model 1220 printer (or former IMP 24). This is a compact low cost printer that is ideal for service work and data logging.

The printer can be obtained by contacting WEIGH-TRONIX at:

WEIGH-TRONIX  
 2320 Airport Blvd.  
 Santa Rosa, CA 95402  
 Phone: 1-800-982-6622 or 1-707-527-5555  
 (International Orders Only)

The part number for the printer that is packaged specifically for YORK is P/N 950915576. The cable to connect the printer can either be locally assembled from the parts listed, or ordered directly from WEIGH-TRONIX under part number 287-040018.

## Parts

The following parts are required:

1. WEIGH-TRONIX model 1220 printer.
2. 2.25” (5.7cm) wide desk top calculator paper.
3. 25 ft. (7.62m) maximum length of Twisted Pair Shielded Cable (minimum 3 conductor), #18 AWG stranded, 300V minimum insulation.
4. One 25-pin Cannon connector and shell.  
 Connector: Cannon P/N DB-25P or equivalent.  
 Shell: Cannon P/N DB-C2-J9.

## Assembly and Wiring

All components should be assembled and wired as shown in Figure 44. Strip the outside insulation back several inches and individual wires about 3/8” (9.5 mm) to connect the cable at the microboard. Do not connect the shield at the printer-end of the cable.

## Obtaining a Printout

A printout is obtained by pressing the PRINT key on the keypad and then pressing either the OPER DATA key or HISTORY key.

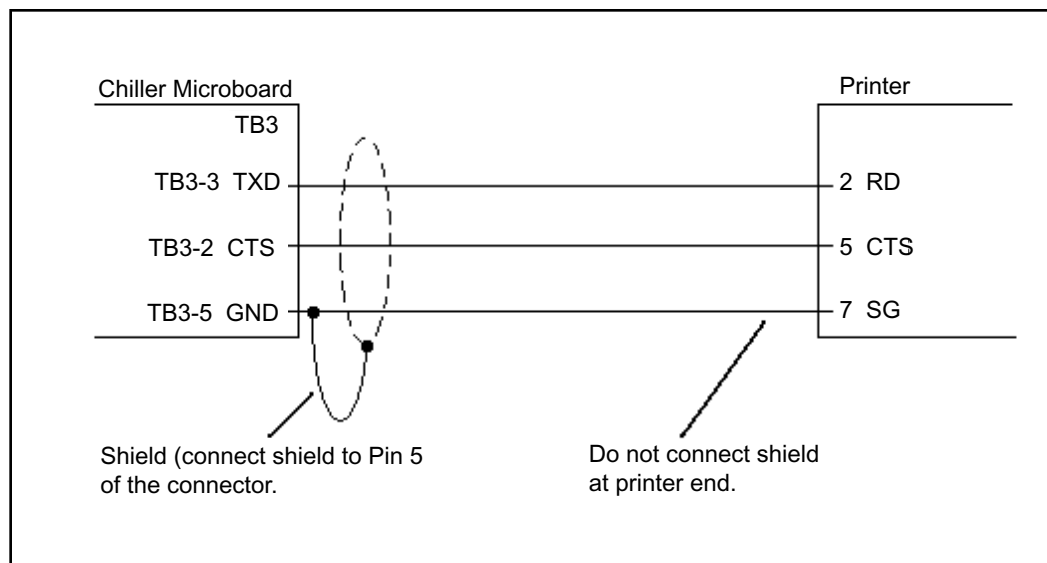

LD12723

**FIGURE 43 - PRINTER TO MICROBOARD ELECTRICAL CONNECTIONS**

## TROUBLESHOOTING

TABLE 29 - TROUBLESHOOTING

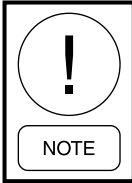
PROBLEM	CAUSE	SOLUTION
<b>NO DISPLAY ON PANEL. UNIT WILL NOT OPERATE.</b>	<ol style="list-style-type: none"> <li>1. No 115VAC to 24 VAC Transformer.</li> <li>2. No 24VAC to Microboard.</li> <li>3. Control Transformer defective, no 24VAC output.</li> <li>4. Short in wire to temp. sensors or pressure transducers.</li> <li>5. Defective IPU II and I/O Board or the Display Board.</li> </ol>	<ol style="list-style-type: none"> <li>1a. Check wiring and fuse 1FU.</li> <li>1b. Check wiring emergency stop contacts 5 to L of XTBC2 Terminal Block.</li> <li>1c. Replace Control Transformer.</li> <li>2. Check wiring Control Transformer to Microboard.</li> <li>3. Replace Control Transformer.</li> <li>4. Unplug connections at IPU II and I/O Board to isolate.</li> <li>5. Replace IPU II and I/O Board or the Display Board.</li> </ol> <div style="display: flex; align-items: center;">  <p><b>Contact Quantech Service Representative before replacing circuit Boards!</b></p> </div>
<b>FLOW SWITCH/REM STOP NO RUN PERMISSIVE</b>	<ol style="list-style-type: none"> <li>1. No air flow.</li> <li>2. Air Proving switch improperly installed.</li> <li>3. Defective Air Proving switch.</li> <li>4. Remote cycling device open.</li> </ol>	<ol style="list-style-type: none"> <li>1. Check air flow.</li> <li>2. Check that the Air Proving switch is installed according to manufacturer's instructions.</li> <li>3. Replace Air Proving switch.</li> <li>4. Check cycling devices connected to terminals 13 and 14 of the XTBC1 Terminal Block.</li> </ol>
<b>LOW SUCTION PRESSURE FAULT</b>	<ol style="list-style-type: none"> <li>1. Improper suction pressure cutouts adjustments.</li> <li>2. Low refrigerant charge.</li> <li>3. Fouled filter dryer.</li> <li>4. TXV defective.</li> <li>5. Reduced air flow</li> <li>6. Defective suction pressure transducer/low pressure switch or wiring.</li> <li>7. LLSV defective</li> </ol>	<ol style="list-style-type: none"> <li>1. Adjust per recommended settings.</li> <li>2. Repair leak if necessary and add refrigerant.</li> <li>3. Change dryer/core.</li> <li>4. Replace TXV.</li> <li>5. Check air flow</li> <li>6. Replace transducer/low pressure switch or faulty switch or wiring. <i>Refer to Service section for pressure/voltage formula.</i></li> <li>7. Replace LLSV</li> </ol>
<b>HIGH DISCHARGE PRESSURE FAULT</b>	<ol style="list-style-type: none"> <li>1. Condenser fans not operating or operating backwards.</li> <li>2. Too much refrigerant.</li> <li>3. Air in refrigerant system.</li> <li>4. Defective discharge pressure transducer.</li> </ol>	<ol style="list-style-type: none"> <li>1. Check fan motor, and contactors. Assure fan blows air upward.</li> <li>2. Remove refrigerant.</li> <li>3. Evacuate and recharge system.</li> <li>4. Replace discharge pressure transducer. <i>Refer to Service section for pressure/voltage formula.</i></li> </ol>



**TABLE 29 - TROUBLESHOOTING (CONT'D)**

PROBLEM	CAUSE	SOLUTION
<b>MP / HPCO FAULT</b>	1. Compressor internal motor protector (MP) open. 2. External overload tripped. 3. HPCO switch open. 4. Defective HPCO switch. 5. Defective CR relay.	1. Verify refrigerant charge is not low. Verify superheat setting of 10 °F to 15 °F (5.6 °C to 8.3 °C). Verify compressor is not overloaded. 2. Determine cause and reset. 3. <i>See High Press. Disch. Fault.</i> 4. Replace HPCO switch. 5. Replace relay.
<b>COMPRESSOR(S) WON'T START</b>	1. Demand not great enough. 2. Defective water temperature sensor. 3. Contactor/Overload failure. 4. Compressor failure.	1. No problem. <i>Consult Installation Manual to aid in understanding compressor operation and capacity control.</i> 2. Compare the display with a thermometer. Should be within plus or minus 2 degrees. <i>Refer to Service section for RWT/LWT temp./voltage table.</i> 3. Replace defective part. 4. Diagnose cause of failure and replace.
<b>LACK OF COOLING EFFECT</b>	1. Check DX Coil. 2. Improper flow through the DX Coil. 3. Low refrigerant charge. Low suction pressure will be observed.	1. Contact the local Quantech representative. 2. Reduce flow to within chiller design specs. <i>See Limitations in Installation section.</i> 3. Check subcooling and add charge as needed.

THIS PAGE INTENTIONALLY LEFT BLANK

## SECTION 10 – MAINTENANCE

It is the responsibility of the equipment owner to provide maintenance on the system.

### IMPORTANT

If system failure occurs due to improper maintenance during the warranty period, Quantech will not be liable for costs incurred to return the system to satisfactory operation. The following is intended only as a guide and covers only the unit components. It does not cover other related system components which may or may not be furnished by Quantech. System components should be maintained according to the individual manufacturer's recommendations as their operation will affect the operation of the unit.

### COMPRESSORS

#### Oil Level check

The oil level can only be tested when the compressor is running in stabilized conditions, to ensure that there is no liquid refrigerant in the lower shell of the compressor. When the compressor is running at stabilized conditions, the oil level must be between 1/4 and 3/4 in the oil sight glass. Note: at shutdown, the oil level can fall to the bottom limit of the oil sight glass. Use YORK "V" oil when adding oil.

#### Oil Analysis

The oil used in these compressors is pale yellow in color (POE oil). If the oil color darkens or exhibits a change in color, this may be an indication of contaminants in the refrigerant system. If this occurs, an oil sample should be taken and analyzed. If contaminants are present, the system must be cleaned to prevent compressor failure.

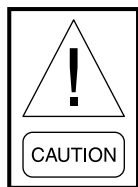

***Never use the scroll compressor to pump the refrigerant system down into a vacuum. Doing so will cause internal arcing of the compressor motor which will result in failure of compressor.***

### CONDENSER FAN MOTORS

Condenser fan motors are permanently lubricated and require no maintenance.

### CONDENSER COILS

Dirt should not be allowed to accumulate on the condenser coil surfaces. Cleaning should be as often as necessary to keep coils clean.

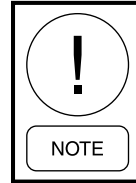

***Exercise care when cleaning the coil so that the coil fins are not damaged.***

### OPERATING PARAMETERS

Regular checks of the system should be performed to ensure that operating temperatures and pressures are within limitations, and that the operating controls are set within proper limits. Refer to the *Operation, Start-Up, and Installation* sections of this manual.

### ON-BOARD BATTERY BACK-UP

U5 is the Real Time Clock chip located on the 031-02630 IPU II board that maintains the date/time and stores customer programmed setpoints. The Real Time Clock is a 128K bram, P/N 031-02565-000. The IPU II board must have JP1 installed when the 128K bram is installed.

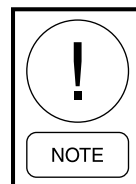

***Do not confuse JP1 on the IPU II (031-02630) board with JP1 on the I/O (031-02550) board.***

### OVERALL UNIT INSPECTION

In addition to the checks listed on this page, periodic overall inspections of the unit should be accomplished to ensure proper equipment operation. Items such as loose hardware, component operation, refrigerant leaks, unusual noises, etc. should be investigated and corrected immediately.

### BACNET, MODBUS AND YORKTALK 2 COMMUNICATIONS

Data can be read and in some cases modified using a serial communication BACnet, Modbus or YorkTalk 2 network connection. This information allows communications of chiller operating parameters and external control changes to setpoint, load limiting, and start/stop commands.

BACnet and YorkTalk 2 RS485 networks are wired to the + and - terminals of TB1 for port 1 communications. Modbus network connection has the option of RS232 or RS485 connection for port 2 communications. Modbus network is wired to either TB2 or TB3 as follows:

- RS-485: connect to TB2 - Network (-1) to TB2 (-1); Network (+1) to TB2 (+1)
- RS-232: connect to TB3 - Network (RX) to TB3 (TXD); Network (TX) to TB3 (RXD); Network (GND) to TB3 (GND)

Refer to Figure 44 on page 153 for TB1, TB2 and TB3 locations.

In most cases, communication parameters will need to be modified. Table 31 on page 154 “Values Required for BAS Communication” lists setup parameters for the available protocols. Modification is accomplished by pressing the PROGRAM, DOWN ARROW, DOWN ARROW, DOWN ARROW, DOWN ARROW, and ENTER keys in sequence. The list below shows the displays for the values that may be modified:

DE MODIFIER ADDRESS XXXXX	P2 PROTOCOL XXXXXXXXXX
DE MODIFIER OFFSET XX	P2 MANUAL MAC ADDRESS XXX
P1 PROTOCOL XXXXXX	P2 BAUD RATE XXXXX
P1 MANUAL MAC ADDRESS XXX	P2 PARITY XXXXX
P1 BAUD RATE XXXXX	P2 STOP BITS X
P1 PARITY XXXXX	P2 HW SELECT BIT XXXXX
P1 STOP BITS X	REAL TIME ERROR ## RESET 1 = YES, 0 = NO 0

Note: See Table 34 for error descriptions

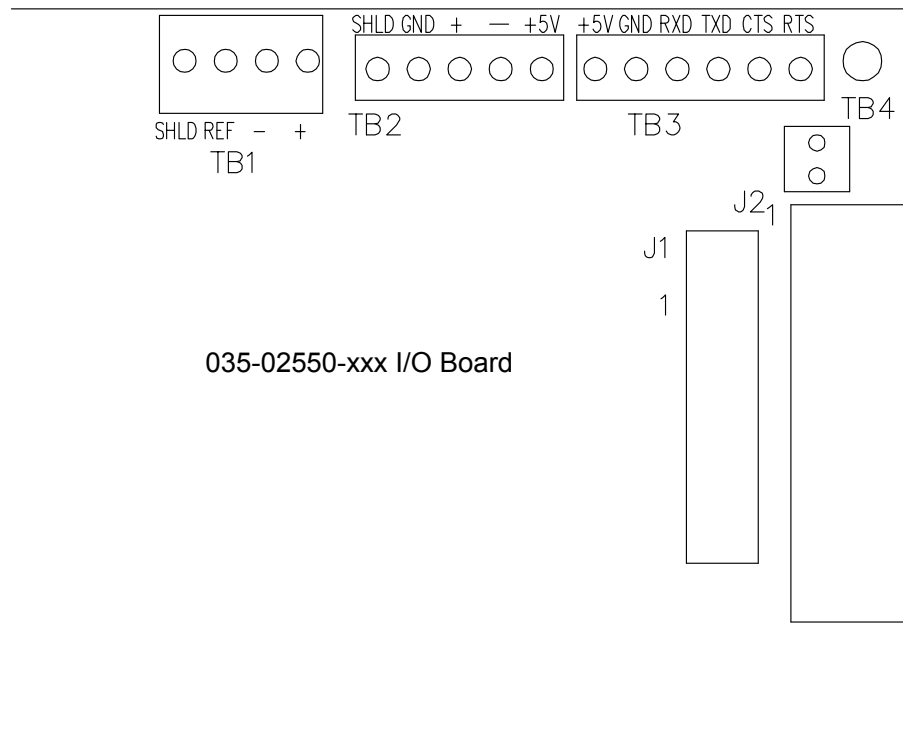

**FIGURE 44 - MICRO PANEL CONNECTIONS**

The table below shows the minimum, maximum, and default values.

**TABLE 30 - MINIMUM, MAXIMUM AND DEFAULT VALUES**

DESCRIPTION	MINIMUM	MAXIMUM	DEFAULT
DE MODIFIER ADDRESS	-1	41943	-1
DE MODIFIER OFFSET	-1	99	-1
P1 BAUD RATE	1200	76800	4800
	1200, 4800, 9600, 19200, 38400, 76800, AUTO SELECTABLE		
P2 BAUD RATE	1200	57600	1200
	1200, 4800, 9600, 19200, 38400, 57600 SELECTABLE		
P1, P2 MANUAL Mac ADDRESS	-1	127	-1
P1, P2 PARITY	NONE	IGNORE	NONE
	NONE, EVEN, ODD, IGNORE SELECTABLE		
P1 PROTOCOL	BACNET	API	BACNET
	BACNET, API SELECTABLE		
P2 PROTOCOL	TERMINAL	MODBUS CLIENT	API
	TERMINAL, MODBUS IO, MODBUS SERVER, API, MODBUS CLIENT selectable		
P1, P2 STOP BITS	1	2	1
RESET REAL TIME ERROR	NO	YES	NO

The table below shows set-up requirements for each communication protocol.

**TABLE 31 - VALUES REQUIRED FOR BAS COMMUNICATION**

SETTING DESCRIPTION	PROTOCOL		
	BACNET MS/TP	MODBUS RTU5	YORKTALK 2
DE MODIFIER ADDRESS	0 to 41943(3)	1	-1
DE MODIFIER OFFSET	0 to 99(4)	0	N/A
P1 PROTOCOL	BACNET	N/A	N/A
P1 MANUAL MAC ADDRESS	0-127(1)	N/A	N/A
P1 BAUD RATE	9600 to 76800 or Auto Selectable(1)	N/A	N/A
P1 PARITY	NONE	N/A	N/A
P1 STOP BITS	1	N/A	N/A
P2 PROTOCOL	N/A	MODBUS SVR	N/A
P2 MANUAL MAC ADDRESS	N/A	0-127(1)	N/A
P2 BAUD RATE	N/A	19,200(2)	N/A
P2 PARITY	N/A	NONE(2)	N/A
P2 STOP BITS	N/A	1	N/A
P2 HW SELECT BIT	N/A	RS-485 or RS-232(1)	N/A
RESET REAL TIME ERROR	N/A	N/A	N/A
P1 HW SELECT BIT	N/A	N/A	N/A
CHILLER ID	N/A	N/A	0

1as required by network

2or other as required by network

3number is multiplied by 100, set as required by network

4number is added to DE MODIFIER ADDRESS, set as required by network

5unit operating software version C.MMC.13.03 or later required for Modbus protocol

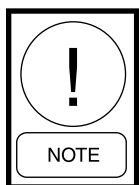

***REBOOT REQUIRED (CYCLE POWER)  
AFTER SETTINGS ARE CHANGED.***

The table below shows the real time error numbers that may be encountered during communication setup and a description of each.

**TABLE 32 - REAL TIME ERROR NUMBERS**

ERROR NUMBER (##)	DESCRIPTION
0	ALL OK
1	DATUM TYPE OK TEST FAILED
2	ENGLISH TEXT TOO LONG
3	FLOATING POINT EXCEPTION
4	GET PACKET FAILED
5	GET TYPE FAILED
6	INVALID UNIT CONVERSION
7	INVALID HARDWARE SELECTION
8	REAL TIME FAULT
9	SPANISH TEXT TOO LONG
10	THREAD EXITED
11	THREAD FAILED
12	THREAD STALLED
13	IO BOARD RESET
14	BRAM INVALID
15	BACNET SETUP FAILED

## BACnet and Modbus Communications

Chiller data that can be read and modified using specific BACnet or Modbus Register Addresses; and the data associated with the addresses, is outlined in the following description:

### ANALOG WRITE POINTS

This data can be read and modified using a BACnet or Modbus network connection. The Modbus Register Address for these points is  $1025 + AV \#$ .

### BINARY WRITE POINTS

This data can be read and modified using a BACnet or Modbus network connection. The Modbus Register Address for these points is  $1537 + BV \#$ .

### ANALOG READ ONLY POINTS

This data can be read using a BACnet or Modbus network connection and can NOT be modified using this connection. The Modbus Register Address for these points is  $513 + AI \#$ .

### BINARY MONITOR ONLY POINTS

This data can be read using a BACnet or Modbus network connection and can NOT be modified using this connection. The Modbus Register Address for these points is  $1281 + BI \#$ .

*Refer to Table 35 for complete list of BACnet and Modbus registers.*

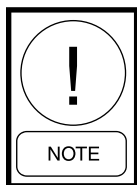

***The latest data map information is listed on the [Quantech Equipment Integration website](#).***

## Communications Data Map Notes

*(See Table 33 on page 156)*

1. IPU II based units are configured for Native BACnet MS/TP and Modbus RTU communications. Microgateway or E-Link not required for these two communication protocols.
2. BACnet Object Types: 0= Analog In, 1 = Analog Out, 2= Analog Value, 3= Binary In, 4 = Binary Output, 5= Binary Value, 8= Device, 15 = Alarm Notification (0 through 127 are reserved ASHRAE Objects).
3. WC= Inches of water column; CFM = Cubic Feet per Minute; FPM = Feet per Minute; PSI = Lbs per square inch; Pa = Pascals; kPa = Kilopascals; PPM = Part per Million; kJ/kg = Kilojoules per Kilogram.
4. Water Cooled Scroll units use the same firmware as Air Cooled Scroll units, ignoring Fan Control.





**TABLE 33 - BACNET AND MODBUS COMMUNICATIONS DATA MAP (CONT'D)**

2/25/2009

ITEM REF NUM	BACnet NAME	BACnet Object/Instance	MODBUS ADDRESS	MODBUS Data Type Supported	ENG UNITS	READ WRITE	POINT DESCRIPTION	Point List Code												
								1	2	3	4	5	6	7	8	9	10			
41	NUM_COMPS	AI_24	537	03.04	count	R	Number of Compressors													
42	S1_OP_CODE	AI_25	538	03.04	index	R	Sys 1 Operational Code (See Table A & B)													
43	S1_FLT_CODE	AI_26	539	03.04	index	R	Sys 1 Fault Code (See Table A & B)													
44	S2_OP_CODE	AI_27	540	03.04	index	R	Sys 2 Operational Code (See Table A & B)													
45	S2_FLT_CODE	AI_28	541	03.04	index	R	Sys 2 Fault Code (See Table A & B)													
46	S1_DBG_CODE	AI_29	542	03.04	index	R	Sys 1 Debug Code													
47	S1_FAN_STAGE	AI_30	543	03.04	count	R	Sys 1 Condenser Fan Stage													
48	S2_DBG_CODE	AI_31	544	03.04	index	R	Sys 2 Debug Code													
49	S2_FAN_STAGE	AI_32	545	03.04	count	R	Sys 2 Condenser Fan Stage													
50	CONTROL_MODE	AI_33	546	03.04	count	R	Unit Control Mode (0=Leaving Water, 1=Return Water, 2=Discharge Air, 3=Suction Press, 4=Cooling, 5=Heating)													
51	AR_TIME	AI_34	547	03.04	seconds	R	Anti-Recycle Time (Programmed)													
52	LCHLT_CUT	AI_35	548	03.04	F°	R	Leaving Chilled Liquid Temp Cutout													
53	LOW_AMB_CUT	AI_36	549	03.04	F°	R	Low Ambient Temperature Cutout													
54	SUCT_P_CO_HT	AI_37	550	03.04	PSIG	R	Low Suction Pressure Cutout Heating (HP Only)													
55	L_SUCT_P_CO	AI_38	551	03.04	PSIG	R	Low Suction Pressure Cutout (Cooling on HP units)													
56	H_DSCH_P_CO	AI_39	552	03.04	PSIG	R	High Discharge Pressure Cutout													
57	COOL_SETUP	AI_40	553	03.04	F°	R	Setpoint													
58	SP_SETUP_S1	AI_41	554	03.04	F°	R	Setpoint 1 (SP Control)													
59	CONTROL_RG	AI_42	555	03.04	F°	R	Cooling Range													
60	SP_CTL_RG_S1	AI_43	556	03.04	F°	R	Cooling Range 1 (SP Control)													
61	SP_SETUP_S2	AI_44	557	03.04	F°	R	Setpoint 2 (SP Control)													
62	HEAT_SETUP	AI_45	558	03.04	F°	R	Heating Setpoint (HP Only)													
63	SP_CTL_RG_S2	AI_46	559	03.04	F°	R	Cooling Range 2 (SP Control)													
64	HEAT_RANGE	AI_47	560	03.04	F°	R	Heating Range (HP Only)													
65	S1_DSCH_TEMP	AI_48	561	03.04	F°	R	Sys 1 Discharge Temperature (EEV Only)													
66	S1_DSCH_SHEAT	AI_49	562	03.04	F°	R	Sys 1 Discharge Superheat (EEV Only)													
67	S2_DSCH_TEMP	AI_50	563	03.04	F°	R	Sys 2 Discharge Temperature (EEV Only)													
68	S2_DSCH_SH	AI_51	564	03.04	F°	R	Sys 2 Discharge Superheat (EEV Only)													
69	LEAVING_HOT	AI_52	565	03.04	F°	R	Leaving Liquid Hot Temp (R-410a)													
70	RETURN_HOT	AI_53	566	03.04	F°	R	Return Liquid Hot Temp (R-410a)													
71																				
72																				
74	<b>BINARY MONITOR ONLY POINTS</b>																			
75	S1_ALARM	BI_1	1282	01.02.03	0.1	R	Sys 1 Alarm													
76	S2_ALARM	BI_2	1283	01.02.03	0.1	R	Sys 2 Alarm													
77	EVAP_HTR	BI_3	1284	01.02.03	0.1	R	Evaporator Heater Status													
78	EVAP_PUMP	BI_4	1285	01.02.03	0.1	R	Evaporator Pump Status													
79	S1_C1_RUN	BI_5	1286	01.02.03	0.1	R	Sys 1 Comp 1 Run													
80	S2_C1_RUN	BI_6	1287	01.02.03	0.1	R	Sys 2 Comp 1 Run													
81	S1_LLSV	BI_7	1288	01.02.03	0.1	R	Sys 1 Liquid Line Solenoid Valve													
82	S1_MODE_SV	BI_8	1289	01.02.03	0.1	R	Sys 1 Mode Solenoid Valve (HP Only)													
83	S1_HGBV	BI_9	1290	01.02.03	0.1	R	Sys 1 Hot Gas Bypass Valve													
84	S1_BHS	BI_10	1291	01.02.03	0.1	R	Bivalent Heat Source (HP Only)													
85	S1_C2_RUN	BI_11	1292	01.02.03	0.1	R	Sys 1 Comp 2 Run													
86	S2_C2_RUN	BI_12	1293	01.02.03	0.1	R	Sys 2 Comp 2 Run													
87	S2_LLSV	BI_13	1294	01.02.03	0.1	R	Sys 2 Liquid Line Solenoid Valve													
88	S2_MODE_SV	BI_14	1295	01.02.03	0.1	R	Sys 2 Mode Solenoid Valve (HP Only)													
89	LEAD_SYS	BI_15	1296	01.02.03	0.1	R	Lead System (0 = Sys. 1, 1 = Sys. 2)													
90	S1_C3_RUN	BI_16	1297	01.02.03	0.1	R	Sys 1 Comp 3 Run													
91	S2_C3_RUN	BI_17	1298	01.02.03	0.1	R	Sys 2 Comp 3 Run													
92	CH_LIQ_TYPE	BI_18	1299	01.02.03	0.1	R	Chilled Liquid Type (0=Water, 1=Glycol)													
93	AMB_MODE	BI_19	1300	01.02.03	0.1	R	Ambient Control Mode (0=Std Amb, 1=Low Amb)													

**TABLE 33 - BACNET AND MODBUS COMMUNICATIONS DATA MAP (CONT'D)**

2/25/2009

ITEM REF NUM	BACnet NAME	BACnet Object/Instance	MODBUS ADDRESS	MODBUS Data Type Supported	ENG UNITS	READ WRITE	POINT DESCRIPTION	Point List Code												
								1	2	3	4	5	6	7	8	9	10			
94	CNTL_MODE	BI 20	1301	01.02.03	0.1	R	Local/Remote Control Mode (0=Local, 1=Remote)													
95	DATA_UNIT	BI 21	1302	01.02.03	0.1	R	Units (0=Imperial, 1=SI)													
96	AUTO_LL	BI 22	1303	01.02.03	0.1	R	Lead/Lag Control Mode (0=Manual, 1=Auto)													

TABLE A

Code	Operational Codes
0	No Abnormal Condition
1	Unit Switch Off
2	System Switch Off
3	Lock-Out
4	Unit Fault
5	System Fault
6	Remote Shutdown
7	Daily Schedule Shutdown
8	No Run Permissive
9	No Cool Load
10	Anti-Coincidence Timer Active
11	Anti-Recycle Timer Active
12	Manual Override
13	Suction Limiting
14	Discharge Limiting
15	Load Limiting
16	Compressor(s) Running
17	
18	
19	
20	
21	
22	
23	
24	
25	
26	
27	
28	
29	
30	

TABLE B

Code	Fault Codes
0	No Fault
1	VAC Under Voltage
2	Low Ambient Temperature
3	High Ambient Temperature
4	Low Leaving Chilled Liquid Temp
5	High Discharge Pressure
6	High Differential Oil Pressure
7	Low Suction Pressure
8	High Motor Current
9	LL SV Not On
10	Low Battery Warning
11	High Oil Temperature
12	High Discharge Temperature
13	Improper Phase Rotation
14	Low Motor Current / MP / HPCO
15	Motor Current Unbalanced
16	Low Differential Oil Pressure
17	Ground Fault
18	MP/HPCO Fault
19	Low Evaporator Temperature
20	Incorrect Refrigerant Programmed
21	Power Failure, Manual Reset Required
22	Unit Motor Current
23	Low Superheat
24	Sensor Fault
25	
26	MP/HPCO Inhibit
27	
28	
29	
30	

NOTES

1	The IPU II based YCAL /YCUL Units are configured for Native BACnet MS/TP and Modbus RTU communications. The Microgateway product is not required for these 2 interfaces
2	
3	BACnet Object Types: 0= Analog In, 1 = Analog Out, 2= Analog Value, 3= Binary In, 4 = Binary Output, 5= Binary Value, 8= Device, 15 = Alarm Notification (0 -127 are reserved ASHRAE Objects)
4	WC= Inches of water column; CFM = Cubic Feet per Minute; FPM = Feet per Minute; PSI = Lbs per square inch; Pa = Pascals; kPa = Kilopascals; PPM = Part Per Million; kJ/kg = Kilojoules per Kilogram
5	See the applicable Middle Market Chiller Operations Manual for more details
6	The QWC3 uses the same firmware as a QTC2, it just ignores Fan Control
7	
8	
9	
10	

Property of Quantech. Subject to change without notice  
Middle Market IPU II NATIVE BACnet\_Modbus Data Maps\_Rev A\_06.xls

## Yorktalk 2 Communications

### **Received Data (Control Data)**

The unit receives 8 data values from the MicroGateway or E-Link. The first 4 are analog values and the last 4 are digital values. These 8 data values are used as control parameters when in REMOTE mode. When the unit is in LOCAL mode, these 8 values are ignored. If the unit receives no valid YorkTalk 2 transmission for 5 minutes it will revert back to all local control values. Table 36 “Yorktalk 2 Communications Data Map” lists the control parameters. These values are found under feature 54 in the MicroGateway or E-Link.

### **Transmitted Data**

After receiving a valid transmission from the MicroGateway or E-Link, the unit will transmit either operational data or history buffer data depending on the “History Buffer Request” on ENG PAGE 10. Data must be transmitted for every page under feature 54. If there is no value to be sent to a particular page, a zero will be sent. Table 36 “Yorktalk 2 Communications Data Map” shows the data values and page listings for this unit.

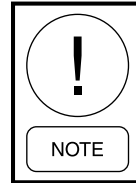

*The latest point map information is listed on the [Quantech Equipment Integration website](#).*

**TABLE 34 - YORKTALK 2 COMMUNICATIONS DATA MAP**

Micro Board: 031-02050/02550

York Talk 2 MicroGateway / ELINK

QTC2, QWC3, QTC3 Middle Market w/ 2050, 2550

Item	Ref.	Version	Date	Quantech PN	Checksum	Baud	Comments											
1		C.MMC.03.02		031-02049-001	944D	4800	QTC2 Micro Board 031-02050-xxx											
2		C.MMC.03.01		031-02049-001	964B	4800	QTC2 Micro Board 031-02050-xxx											
3		C.MMC.03.00		031-02049-001	2226	4800	QTC2 Micro Board 031-02050-xxx											
4		C.MMC.13.xx		flash	xxxx	4800	QTC2 Micro Board 031-02550-xxx, IPU 2 board.											
5		C.MMC.13.xx		flash	xxxx	4800	QWC3 ( water cooled version) Micro Board 031-02550-xxx, IPU 2 board.											
6		C.MMC.13.02		flash	xxxx	4800	Micro Board 031-02550-xxx. Fix native Modbus communications (SCR . Fix Café Metric functionality (SCR-766)											
7																		
8																		
9																		
10																		
<p><b>Use ASCII page column for interfaces utilizing an ASCII XL Transistor or MicroGateway to communicate to a chiller LINC</b></p>																		
ENG PAGE REF	ASCII PAGE REF	GPIC Object Type	York Talk Point Type	ISN LINC Descriptive Text	York Talk Character Position	N2 Address	POINT LIST DESCRIPTION	1	2	3	4	5	6	7	8	9	10	ENG PAGE REF
P03	P01		A. Control			ADF 1	Setpoint	S	S	S	S	S	S					P03
P04	P02		A. Control			ADF 2	Load Limit Stage (0, 1, 2)	S	S	S	S	S	S					P04
P05	P03		A. Control			ADF 3	Heating Setpoint (HP and YCWL HP)	O	O	O	O	O	O					P05
P06	P04		A. Control			ADF 4	Mode (HP and YCWL HP only) (0=Panel, 1 = Cooling, 2 = Heating)	O	O	O	O	O	O					P06
P07	P05		D. Control			BD 1	Start/Stop Command	S	S	S	S	S	S					P07
P08	P06		D. Control			BD 2												P08
P09	P07		D. Control			BD 3												P09
P10	P08		D. Control			BD 4	History Buffer Request	S	S	S	S	S	S					P10
P11	P09		A. Monitor		8 - 11	ADF 5	Leaving Chilled Liquid Temp	S	S	S	S	S	S					P11
P12	P10		A. Monitor		12 - 15	ADF 6	Return Chilled Liquid Temp	S	S	S	S	S	S					P12
P13	P11		A. Monitor		16 - 19	ADF 7	Leaving Hot Liquid Temp (R-410a) Heat Mode Only	O	O	O	O	O	O					P13
P14	P12		A. Monitor		20 - 23	ADF 8	Discharge Air Temp ( Cond Unit) Return Hot Liquid Temp (410a- Heat Mod	O	O	O	O	O	O					P14
P15	P13		A. Monitor		24 - 27	ADF 9	Leaving Liquid Temp Hot (R-410a)	O	O	O	O	O	O					P15
P16	P14		A. Monitor		28 - 31	ADF 10	Ambient Air Temperature	S	S	S	S	S	S					P16
P17	P15		A. Monitor		32 - 35	ADF 11	Sys 1 Suction Superheat ( EEV only)	O	O	O	O	O	O					P17
P18	P16		A. Monitor		36 - 39	ADF 12	Sys 1 Run Time (seconds)	S	S	S	S	S	S					P18
P19	P17		A. Monitor		40 - 43	ADF 13	Sys 1 Suction Pressure	S	S	S	S	S	S					P19
P20	P18		A. Monitor		44 - 47	ADF 14	Sys 1 Discharge Pressure	S	S	S	S	S	S					P20
P21	P19		A. Monitor		48 - 51	ADF 15	Sys 1 Cooler Inlet Refrigerant Temperature(R-407c Only)	S	S	S	S	S	S					P21
P22	P20		A. Monitor		52 - 55	ADF 16		O	O	O	O	O	O					P22
P23	P21		A. Monitor		56 - 59	ADF 17	Sys 1 EEV Output % (EEV only)	S	S	S	S	S	S					P23
P24	P22		A. Monitor		60 - 63	ADF 18	Sys 1 Anti-Recycle Timer	S	S	S	S	S	S					P24
P25	P23		A. Monitor		64 - 67	ADF 19	Anti-Coincident Timer	S	S	S	S	S	S					P25
P26	P24		A. Monitor		68 - 71	ADF 20	Sys Suction Temp ( EEV only)	O	O	O	O	O	O					P26
P27	P25		A. Monitor		72 - 75	ADF 21	Sys 2 Run Time (seconds)	S	S	S	S	S	S					P27
P28	P26		A. Monitor		76 - 79	ADF 22	Sys 2 Suction Pressure	S	S	S	S	S	S					P28
P29	P27		A. Monitor		80 - 83	ADF 23	Sys 2 Discharge Pressure	S	S	S	S	S	S					P29
P30	P28		A. Monitor		84 - 87	ADF 24	Sys 2 Cooler Inlet Refrigerant Temperature (R-407c systems Only)	S	S	S	S	S	S					P30
P31	P29		A. Monitor		88 - 91	ADF 25	Sys 2 Defrost Temperature (HP only)	O	O	O	O	O	O					P31
P32	P30		A. Monitor		92 - 95	ADF 26	Sys 2 Suction Superheat (EEV only)	O	O	O	O	O	O					P32
P33	P31		A. Monitor		96 - 99	ADF 27	Sys 2 Anti-Recycle Timer	S	S	S	S	S	S					P33
P34	P32		A. Monitor		100 - 103	ADF 28	Sys 2 EEV Output % (EEV only)	O	O	O	O	O	O					P34
P35	P33		A. Monitor		104 - 107	ADF 29	Number of Compressors	S	S	S	S	S	S					P35
P36	P34		D. Monitor		108	BD 5	Sys 1 Alarm	S	S	S	S	S	S					P36
P37	P35		D. Monitor		109	BD 6	Sys 2 Alarm	S	S	S	S	S	S					P37
P38	P36		D. Monitor		110	BD 7	Evaporator Heater Status	S	S	S	S	S	S					P38
P39	P37		D. Monitor		111	BD 8	Evaporator Pump Status	S	S	S	S	S	S					P39
P40	P38		D. Monitor		112	BD 9	Sys 1 Compressor 1 Run	S	S	S	S	S	S					P40
P41	P39		D. Monitor		113	BD 10	Sys 2 Compressor 1 Run	S	S	S	S	S	S					P41
P42	P40		D. Monitor		114	BD 11	Sys 1 Liquid Line Solenoid Valve	S	S	S	S	S	S					P42





## TEMPERATURE CONVERSION CHART

° F	=	° C	° C	=	° F
0		-17.8	-18		-0.4
4		-15.6	-16		3.2
8		-13.3	-14		6.8
12		-11.1	-12		10.4
16		-8.9	-10		14
20		-6.7	-8		17.6
24		-4.4	-6		21.2
28		-2.2	-4		24.8
32		0.0	-2		28.4
36		2.2	0		32
40		4.4	2		35.6
44		6.7	4		39.2
48		8.9	6		42.8
52		11.1	8		46.4
56		13.3	10		50
60		15.6	12		53.6
64		17.8	14		57.2
68		20.0	16		60.8
72		22.2	18		64.4
76		24.4	20		68
80		26.7	22		71.6
84		28.9	24		75.2
88		31.1	26		78.8
92		33.3	28		82.4
96		35.6	30		86
100		37.8	32		89.6
104		40.0	34		93.2
108		42.2	36		96.8
112		44.4	38		100.4
116		46.7	40		104
120		48.9	42		107.6
124		51.1	44		111.2
128		53.3	46		114.8
132		55.6	48		118.4
136		57.8	50		122
140		60.0	52		125.6
144		62.2	54		129.2
148		64.4	56		132.8
152		66.7	58		136.4
156		68.9	60		140
160		71.1	62		143.6
164		73.3	64		147.2
168		75.6	66		150.8
172		77.8	68		154.4
176		80.0	70		158
180		82.2	72		161.6
184		84.4	74		165.2
188		86.7	76		168.8
192		88.9	78		172.4
196		91.1	80		176
200		93.3	82		179.6
204		95.6	84		183.2
208		97.8	86		186.8
212		100.0	88		190.4
216		102.2	90		194
220		104.4	92		197.6
224		106.7	94		201.2
228		108.9	96		204.8
232		111.1	98		208.4
236		113.3	100		212
240		115.6	102		215.6
244		117.8	104		219.2

° F	=	° C	° C	=	° F
0		0	0		0
4		2.2	2		3.6
8		4.4	4		7.2
12		6.7	6		10.8
16		8.9	8		14.4
20		11.1	10		18
24		13.3	12		21.6
28		15.6	14		25.2
32		17.8	16		28.8
36		20	18		32.4
40		22.2	20		36
44		24.4	22		39.6
48		26.7	24		43.2
52		28.9	26		46.8
56		31.1	28		50.4
60		33.3	30		54

### Pressure Conversion Chart - Gauge or Differential

PSI	=	BAR	BAR	=	PSI
20		1.38	1.5		21.8
30		2.07	2		29
40		2.76	2.5		36.3
50		3.45	3		43.5
60		4.14	3.5		50.8
70		4.83	4		58
80		5.52	4.5		65.3
90		6.21	5		72.5
100		6.9	5.5		79.8
110		7.59	6		87
120		8.28	6.5		94.3
130		8.97	7		101.5
140		9.66	7.5		108.8
150		10.34	8		116
160		11.03	8.5		123.3
170		11.72	9		130.5
180		12.41	9.5		137.8
190		13.1	10		145
200		13.79	10.5		152.3
210		14.48	11		159.5
220		15.17	11.5		166.8
230		15.86	12		174
240		16.55	12.5		181.3
250		17.24	13		188.5
260		17.93	13.5		195.8
270		18.62	14		203
280		19.31	14.5		210.3
290		20	15		217.5
300		20.69	15.5		224.8
310		21.38	16		232
320		22.07	16.5		239.3
330		22.76	17		246.5
340		23.45	17.5		253.8
350		24.14	18		261
360		24.83	18.5		268.3
370		25.52	19		275.5
380		26.21	19.5		282.8
390		26.9	20		290
400		27.59	20.5		297.3

## R410A PRESSURE TEMPERATURE CHART

PSIG	TEMP °F	PSIG	TEMP °F
0	-60	78	20
2	-58	80	21
4	-54	85	24
6	-50	90	26
8	-46	95	29
10	-42	100	32
12	-39	105	34
14	-36	110	36
16	-33	115	39
18	-30	120	41
20	-28	125	43
22	-26	130	45
24	-24	135	47
26	-20	140	49
28	-18	145	51
30	-16	150	53
32	-14	160	57
34	-12	170	60
36	-10	180	64
38	-8	190	67
40	-6	200	70
42	-4	210	73
44	-3	220	76
46	-2	225	78
48	0	235	80
50	1	245	83
52	3	255	85
54	4	265	88
56	6	275	90
58	7	285	92
60	8	295	95
62	10	305	97
64	11	325	101
66	13	355	108
68	14	375	112
70	15	405	118
72	16	500	134
74	17	600	149
76	19	700	159



## NOTES

